

# K-DRIVE



Heavy Duty High-Performance Series

KD600 Series

## UserManual



<http://www.keanyautomation.com>



# Preface

Thank you for purchasing the AC drive developed by Our company.

AC drives are general type inverters with vector control based on KD600. High quality, multiple functions and low noise, developed independently by ourselves. It can realize open loop and close loop control of different mode, and also signal detection of PT100/PT1000 motor temperature. It supports speed sensorless vector control, sensor vector control and V/F control. Performance of motor control has been improved obviously. Easy operation, perfect self-learning of motor static and dynamic state.

AC drives are compact structure, easy installation, and reasonable heat dissipation design, that ensure reliability of product. Various of expansion cards are available for your choice.

We provide information of model selection, installation, parameter setting, field debugging, fault diagnosis and daily maintenance for users in this manual.

## First-time Use

For the users who use this product for the first time, read the manual carefully. If in doubt concerning some functions or performances, contact the technical support personnel of Our company to ensure correct use.

### ATTENTIONS

- ~~Pl~~ ~~se~~ power off when wiring.
- Electronic components inside AC drive are especially sensitive to static electricity, do not put anything into internal of AC drive. And do not touch main circuit board.
- ⚠ Power cut, if indicator is still lamp, it still have high voltage in AC drive. It is very dangerous, please do not touch internal circuit and components.
- ⚠ Ensure the grounding terminals of AC drive is grounded correctly.
- ⚠ Connect input power supply with output terminal U,V,W of AC drive.

# Contents

## Chapter 1 Safety and Attentions

1.1 Safety Matters. ....	6
1.2 Use Considerations. ....	9

## Chapter 2 Product Brief Introduction

2.1 Position and content of nameplate. ....	12
2.2 Nameplate model description and rated parameters. ....	12
2.3 Specifications and models of AC drives. ....	13
2.4 Technical Features. ....	15
2.5 All components schematic diagram of AC drive. ....	18
2.6 Appearance and installation dimensions. ....	19
2.7 External keyboard with tray installation dimension drawing. ....	22
2.8 Optional accessories. ....	22

## Chapter 3 installation

3.1 Mechanical installation. ....	24
3.2 Electrical Installation. ....	28
3.3 Basic wiring diagram. ....	31
3.4 Wiring (For LCD panel) ....	33
3.5 Main circuit terminals and connection. ....	36
3.6 Control circuit terminal and wiring. ....	39
3.7 Treatment of EMC problem. ....	44

## Chapter 4 Operation and Display

4.1 Keypad description. ....	48
4.2 Organization of Inverter Function Codes. ....	50
4.3 Function code viewing and modification method description. ....	50
4.4 Function code menu mode and switching instructions. ....	51
4.5 Preparation before running. ....	54
4.6 Start-stop control of inverter. ....	58
4.7 Frequency converter operating frequency control. ....	64
4.8 Motor characteristic parameter setting and automatic tuning. ....	72
4.9 How to use the DI port of the inverter. ....	74
4.10 How to use the DO port of the inverter. ....	75

4.11 AI input signal characteristics and preprocessing.....	76
4.12 How to use the AO port of the inverter.....	77
4.13 How to use inverter serial communication.....	78
4.14 Password setting.....	78

## Chapter 5 Function & Parameter Table

5.1 Functional group.....	80
---------------------------	----

## Chapter 6 Function & Parameter Table

Group P0: Basic function group.....	126
Group P1: Start-stop control.....	138
Group P2: V/F control parameters.....	143
Group P3: Vector control parameters.....	148
Group P4: First motor parameter.....	153
Group P5: Vector control parameters.....	156
Group P6: Output terminal.....	168
Group P7: Accessibility and keyboard display.....	174
Group P8: Communication parameters.....	190
Group P9: Fault and Protection.....	192
Group PA: PID function.....	201
Group Pb: Swing Frequency, Fixed Length and Count.....	208
Group PC: Multi-segment instruction and simple PLC function.....	211
Group PD: Torque control.....	217
Group PE: AI multi-point curve setting.....	221
Group A0: Second motor parameter setting.....	223
Group A1: Second Motor Parameters.....	224
Group A2: Second motor VF parameter setting.....	225
Group A3: Second motor vector control parameters.....	225
Group B0: System parameters.....	226
Group B1: User function code customization.....	228
Group B2: Optimize control parameters.....	230
Group B3: AIAO correction parameters.....	232
Group B4: Master-slave control parameters.....	233
Group B5: Brake function parameters.....	235
Group B6: Sleep wakeup function parameters.....	238
Group U0: Fault logging parameters.....	241
Group U1: Application Monitoring Parameters.....	241

## Chapter 7 Synchronous Motor Open Loop Vector (SVC) Commissioning Instructions

7.1 Set the synchronization type, control method and motor parameters.....	246
7.2 Parameter identification.....	246
7.3 No-load test run.....	246
7.4 Quick start test run.....	246
7.5 Load and run.....	247

## **Chapter 8 EMC (Electromagnetic Compatibility)**

8.1 Definition.....	250
8.2 Introduction to EMC Standards.....	250
8.3 EMC Guidance.....	250

## **Chapter 9 Troubleshooting and Countermeasures**

9.1 Fault alarm and countermeasures.....	256
9.2 Common faults and their solutions.....	261
9.3 Common faults of synchronous motors and their solutions.....	263

## **Chapter 10 Appendix**

Appendix A: Modbus communication protocol.....	266
Appendix B: Introduction to Expansion Card.....	276
Appendix C: Expansion Card Details.....	298
Appendix D: KD600E elevator/lift series Vfd detailed explanations.....	316

## **Warranty**

### **Warranty Card**

### **Certificate of quality**





# Chapter 1

---





## **Safety and Attentions**





1.1 Safety Matters .....	6
1.2 Use Considerations .....	9







Users are requested to read this chapter carefully when installing, commissioning and repairing this product and perform the operation according to safety precautions as set forth in this chapter without fail. Our company will bear no responsibility for any injury and loss as a result of any violation operation.

Safety signs in this manual	
 <b>DANGER</b>	Dangers caused by operations beyond requirements may lead to serious injury, and even death.
 <b>CAUTION</b>	Dangers caused by operations beyond requirements may lead to moderate damages or minor injuries, as well as equipment damages.

## 1.1 Safety Matters

Use Stage	Safety Grade	Precautions
Before Installation	 <b>DANGER</b>	<ul style="list-style-type: none"> <li>⊘ Do not install the product if the package is with water, or component is missing or broken;</li> <li>⊘ Do not install the product if the label on the package is not identical to that on the inverter.</li> </ul>
	 <b>CAUTION</b>	<ul style="list-style-type: none"> <li>⊘ Be careful of carrying or transportation. Risk of device damage;</li> <li>⊘ Do not use damaged product or the inverters missing component. Risk of injury;</li> <li>⊘ Do not touch the parts of control system with bare hands. Risk of ESD hazard.</li> </ul>
Installation	 <b>DANGER</b>	<ul style="list-style-type: none"> <li>◇ Installation base shall be metal or other non-flammable material. Risk of fire;</li> <li>⊘ Do not install inverter in an environment containing explosive gases, otherwise there is danger of explosion;</li> <li>⊘ Do not unscrew the fixing bolts, especially the bolts with red mark.</li> </ul>
	 <b>DANGER</b>	<ul style="list-style-type: none"> <li>⊘ Do not leave cable strips or screws in the inverter. Risk of inverter damage;</li> <li>◇ Place the product at the place with less vibration and no direct sunlight;</li> </ul>

Use Stage	Safety Grade	Precautions
Installation	 DANGER	<ul style="list-style-type: none"> <li>✘ the installation space for cooling purpose when two or more inverters are placed in the same cabinet.</li> </ul>
Wiring	 DANGER	<ul style="list-style-type: none"> <li>✘ must be performed by authorized and qualified personnel. Risk of danger;</li> <li>✘ breaker should be installed between inverter and the mains. Risk of fire;</li> <li>✘ ensure the input power supply has been completely disconnected before wiring. Failure to comply may result in personnel injury and/or equipment damage;</li> <li>✘ overall leakage current of this equipment may be bigger than 3.5mA, for safety's sake, this equipment and its associated motor must be well grounded so as to avoid risk of electric shock;</li> <li>✘ connect the power cables to the output terminals (U,V,W) of the AC drive. Pay attention to the marks of the wiring terminals and ensure correct wiring. Failure to comply will result in damage to the AC drive;</li> <li>✘ braking resistors at terminals (P+)and (P- or PB) only. Failure to comply may result in equipment damage.</li> </ul>
	 CAUTION	<ul style="list-style-type: none"> <li>✘ all adjustable frequency AC drives from Our company have been subjected to hi-pot test before delivery, users are prohibited from implementing such a test on this equipment. Failure to comply may result in equipment damage.</li> <li>✘ wires should to the best of the possibility be away from main power lines. If this cannot be ensured, vertical cross-arrangement shall be implemented, otherwise interference noise to control signal may occur.</li> <li>✘ motor cables are longer than 100m, it is recommend- ed output AC reactor be used. Failure to comply may result in faults.</li> </ul>
Before Power-on	 DANGER	<ul style="list-style-type: none"> <li>✘ shall be power-on only after the front cover is assembled. Risk of electrical hazard.</li> </ul>
	 CAUTION	<ul style="list-style-type: none"> <li>✘ that the input voltage is identical to the rated voltage of product, correct wiring of input terminals R,</li> </ul>

Use Stage	Safety Grade	Precautions
Before Power-on	 CAUTION	S, T or L1, L2 and output terminals U, V, and W, wiring of inverter and its peripheral circuits, and all wires should be in good connection. Risk of inverter damage.
After Power-on	 DANGER	<ul style="list-style-type: none"> <li>✘ Do not open the cover after power. Risk of electrical hazard;</li> <li>✘ Do not touches any input/output terminals of inverter with bare hands. Risk of electrical hazard.</li> </ul>
	 CAUTION	<ul style="list-style-type: none"> <li>✘ Auto tuning is required, be careful of personal injury when motor is running. Risk of accident;</li> <li>✘ Do not change the defaults of parameters. Risk of devices damage.</li> </ul>
During Operation	 DANGER	<ul style="list-style-type: none"> <li>✘ Professionals shall not detect signals during operation. Risk of personal injury or device damage;</li> <li>✘ Do not touch the fan or the discharging resistor to check the temperature. Failure to comply will result in personal burnt.</li> </ul>
	 CAUTION	<ul style="list-style-type: none"> <li>✘ Do not leave any foreign items from being left in the devices during operation. Risk of device damage;</li> <li>✘ Do not control start/stop of inverter by ON/OFF of contactor. Risk of device damage.</li> </ul>
Maintenance	 DANGER	<ul style="list-style-type: none"> <li>✘ Do not make repair and maintenance over equipment in a charged state, or it will give rise to electric shock hazard!</li> <li>✘ Drive can be put into maintenance and repair only you confirm the AC drive charge light out, or the remaining electric charge of capacitance will cause damages to people!</li> <li>✘ People who are not trained professionally cannot make repair and maintenance, or it will cause personal injuries or equipment troubles!</li> </ul>

## 1.2 Use Considerations

### 1.2.1 Motor Insulation Inspection

When the motor is used for the first time or when the motor is reused after being kept, or when periodical inspection is performed, insulation inspection shall be conducted with motor so as to avoid damaging the inverter because of the insulation failure of the motor windings. The motor wires must be disconnected from the inverter during the insulation inspection. It is recommended to use the 500V mega meter, and the insulating resistance measured shall be 5M $\Omega$  at least.

### 1.2.2 Motor Thermal Protection

If the motor rating does not match that of the inverter, especially when the rated power of the inverter is higher than that of the motor, adjust motor protection parameters in the inverter or install thermal relay to protect motor.

### 1.2.3 Operating with the Frequency Higher than Grid Power Frequency

Output frequency of is 0.00Hz~500Hz. If product is required to operate above 50.00Hz, please take the endurance of mechanical devices into consideration.

### 1.2.4 Mechanical Vibrations

Inverter may encounter mechanical resonance point of the load device at certain output frequencies which can be avoided by setting the skip frequency parameters of the inverter.

### 1.2.5 Motor Heat and Noise

Since output voltage of inverter is PWM wave and contains a certain amount of harmonics, so that the temperature, noise and vibration of the motor will be higher than those when the inverter runs at grid power frequency.

### 1.2.6 Voltage-sensitive device or capacitor on output side of the AC drive

Do not install the capacitor for improving power factor or lightning protection voltage-sensitive resistor on the output side of the AC drive because the output of the AC drive is PWM wave. Otherwise, the AC drive may suffer transient overcurrent or even be damaged.

### 1.2.7 Contactor at the I/O terminal of the AC drive

When a contactor is installed between the input side of the AC drive and the power supply, the AC drive must not be started or stopped by switching the contactor on or off. If the AC drive has to be operated by the contactor, ensure that the time interval between switching is at least one hour since frequent charge and discharge will shorten the service life of the capacitor inside the AC drive;

When a contactor is installed between the output side of the AC drive and the motor, do not turn off the contactor when the AC drive is active. Otherwise, modules inside the AC drive may be damaged.

### **1.2.8 Applied with the Rated Voltage**

Apply product with the rated voltage. Failure to comply will damage inverter. If required, take a transformer to boost or step-down voltage.

### **1.2.9 Do Not Apply a 3-Phase Input Inverter to 2-Phase Input Applications**

Do not apply a 3-phase input FR inverter to 2-phase input applications. Otherwise, it will result in faults or damage inverter.

### **1.2.10 Lightning Protection**

The product has integrated lightning over-current protection device which has certain self-protection capacity against the lightning. Additional protection devices have to be installed between inverter and power supply in the area where lightning occurs frequently.

### **1.2.11 Altitude De-rating**

In places where the altitude is above 1000 m and the cooling effect reduces due to thin air, it is necessary to de-rate the AC drive. Contact Our company for technical support.

### **1.2.12 Adaptable Motor**

Standard adaptive motor is quadrupole squirrel-cage asynchronous induction motor. If it is not above-mentioned motor, please select AC drive upon rated current of motor. If you need to drive permanent magnet synchronous motor, please consult our company;

The cooling fan of non variable frequency motor and rotor spindle are coaxially connected. While despinning, the fan cooling effect also declines at the same time. Hence, for overheated occasion of motor, you shall install strong exhaust fan or change variable frequency motor;

AC drives have built-in adaptive motor standard parameters. It is necessary to make motor parameter identification or amend default values to accord with actual values, or it will influence operation effects and protective values;

As short circuit existing inside cable or motor will cause inverter alarming, even explosion. Therefore, please make insulation short-circuit test of initial installed motor and cable first. And the test also is necessary in routine maintenance.



# Chapter 2

---

## Product Brief Introduction

2.1	Position and content of nameplate.....	12
2.2	Nameplate model description and rated parameters.....	12
2.3	Specifications and models of AC drives.....	13
2.4	Technical Features.....	15
2.5	All components schematic diagram of AC drive.....	18
2.6	Appearance and installation dimensions.....	19
2.7	External keyboard with tray installation dimension drawing.....	21
2.8	Optional accessories.....	22

## 2.1 Position and content of nameplate

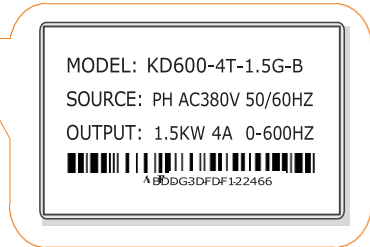

## 2.2 Nameplate model description and rated parameters

4
T
-
1.5
G
-
B

1
2
3
4
5

Code	No.	Content
Voltage level	①	2 : 220V    4 : 380V
Voltage Classification	②	S : Single-phase    T : Three phase
Adapted motor powe	③	0.75KW~400KW
Model	④	Heavy-duty
Accessory type	⑤	Brake unit

## 2.3 Specifications and models of AC drives

Models	Rated input current (A)	Rated output current(A)	Adaptive motor (KW)
<b>Single-phase 220V range: -15%~20%</b>			
KD600-2S-0.4G-B	5.4	2.3	0.4
KD600-2S-0.75G-B	8.2	4	0.75
KD600-2S-1.5G-B	14	7	1.5
KD600-2S-2.2G-B	23	9.6	2.2
KD600-2S-4.0G-B	32	17	4.0
KD600-2S-5.5G-B	45	15	5.5
<b>Three-phase 380V range: -15%~20%</b>			
KD600-4T-0.75G/1.5P	3.4	2.1	0.75
KD600-4T-1.5G/2.2P	5.0/5.8	3.8/5.1	1.5/2.2
KD600-4T-2.2G/4.0P	5.8/10.5	5.1/9	2.2/3.7
KD600-4T-4.0G/5.5P	10.5/14.6	9/13	3.7/5.5
KD600-4T-5.5G/7.5P	14.6/20.5	13/17	5.5/7.5
KD600-4T-7.5G/9.0P	20.5/22	17/20	7.5/11
KD600-4T-9.0G/11P	22/26	20/25	18/24
KD600-4T-11G/15P	26/35	25/32	11/15
KD600-4T-15G/18P	35/38.5	32/37	15/18.5
KD600-4T-18G/22P	38.5/46.5	37/45	18.5/22
KD600-4T-22G/30P	46.5/62	45/60	22/30
KD600-4T-30G/37P	62/76	60/75	30/37
KD600-4T-37G/45P	76/92	75/90	37/45
KD600-4T-45G/55P	92/113	90/110	45/55
KD600-4T-55G/75P	113/157	110/152	55/75
KD600-4T-75G/93P	157/180	152/176	75/93
KD600-4T-93G/110P	180/214	176/210	93/110
KD600-4T-110G/132P	214/256	210/253	110/132
KD600-4T-132G/160P	256/307	253/304	132/160
KD600-4T-160G/185P	307/345	304/340	160/185
KD600-4T-185G/200P	345/385	340/380	185/200
KD600-4T-200G/220P	385/430	380/426	200/220
KD600-4T-220G/250P	430/468	426/465	220/250
KD600-4T-250G/280P	468/525	465/520	250/280
KD600-4T-280G/315P	525/590	520/585	280/315
KD600-4T-315G/355P	590/665	585/650	315/350

Models	Rated input current (A)	Rated output current(A)	Adaptive motor (KW)
KD600-4T-355G/400P	665/785	650/725	350/400
KD600-4T-400G/450P	785/883	725/820	400/450
KD600-4T-450G/500P	883/920	820/900	450/500
KD600-4T-500G/550P	920/1020	900/1000	500/550
KD600-4T-550G/630P	1020/1120	1000/1100	550/630
KD600-4T-630G	1120	1100	630
KD600-4T-710G	1315	1250	710
KD600-4T-800G	1525	1450	800
<b>Three-phase 660V-690 range: -15%~20%</b>			
KD600-7T-11G	15.6	15	11
KD600-7T-15G	21	20	15
KD600-7T-18G	26	24	18.5
KD600-7T-22G	32	28	22
KD600-7T-30G	42	38	30
KD600-7T-37G	49.5	47	37
KD600-7T-45G	58	55	45
KD600-7T-55G	70	65	55
KD600-7T-75G	90	86	75
KD600-7T-93G	105	100	93
KD600-7T-110G	130	120	110
KD600-7T-132G	170	150	132
KD600-7T-160G	200	175	160
KD600-7T-185G	208	198	185
KD600-7T-200G	235	215	200
KD600-7T-220G	247	245	220
KD600-7T-250G	265	260	250
KD600-7T-280G	305	299	280
KD600-7T-315G	350	330	315
KD600-7T-355G	382	374	350
KD600-7T-400G	435	410	400
KD600-7T-450G	490	465	450
KD600-7T-500G	595	550	500
KD600-7T-550G	605	600	550
KD600-7T-630G	684	650	630
KD600-7T-710G	768.5	730	710

## 2.4 Technical Features

	Technical Features	Description
Control performance	Highest frequency	Vector control: 0~600Hz VF control: 0~1200Hz
	Carrier frequency	1K~15kHz; the carrier frequency can be adjusted automatically according to the load characteristics.
	Input frequency resolution	Digital setting: 0.01Hz Analog setting: maximum frequency × 0.1%
	Control mode	Open loop vector control (SVC), V/F control
	Starting torque	G type machine: 0.5Hz/180% (open loop vector control) P type machine: 0.5Hz/120% (open loop vector control)
	Speed range	1: 200 (open loop vector control)
	Steady speed accuracy (speed control accuracy)	Open-loop vector control: $\pm 0.5\%$ (rated synchronous speed)
	Speed control stability	Open-loop vector control: $\pm 0.3\%$ (rated synchronous speed)
	Torque Response	$\leq 40\text{ms}$ (open loop vector control)
	Overload capability	Model G: 150% rated current for 60 seconds; 180% rated current for 5 seconds P-type machine: 120% rated current for 60 seconds; 150% rated current for 5 seconds
	Torque boost	Automatic torque boost; manual torque boost 0.1%~ 30.0%
	V/F curve	Three ways: linear type; multi-point type; square type V/F curve
	Acceleration and deceleration curve	Linear or S-curve acceleration and deceleration mode; four kinds of acceleration and deceleration time; acceleration and deceleration time range 0.0s ~ 3000.0s
	DC brake	DC braking frequency: 0.0Hz~maximum frequency, braking time: 0.0~36.0 seconds, braking action current value: 0.0%~100.0%
	Jogging Control	Jog frequency range: 0.00Hz~50.00Hz; Jog acceleration and deceleration time 0.0s~3000.0s
	Simple PLC & multi step speed operation	Built-in PLC or control terminal, 16 steps speed can be set
Built-in PID	Process control closed-loop control system can be easily realized	

	Technical Features	Description
Control performance	Automatic voltage regulation(AVR)	When the grid voltage changes, it can automatically keep the output voltage constant
	Torque Limiting and Control	"Excavator" feature, automatically limit the torque during operation to prevent frequent overcurrent tripping; closed-loop vector mode can realize torque control
Personalization	Power-on peripheral device safety self-check	It can realize safety detection of peripheral equipment such as grounding, short circuit, etc.
	Common DC bus function	It can realize the function of sharing the DC bus of multiple inverters
	JOG key	Programmable keys: forward and reverse running/jog running function selection
	Textile swing frequency control	Various triangular wave frequency control functions
	Fast current limiting function	The built-in fast current limiting algorithm reduces the probability of overcurrent reported by the inverter and improves the anti-interference ability of the whole machine
	Timing control	Timing control function: Set time range 0h~65535h
	Standardized keyboard extension cables	Customers can use standard network cables to extend the keyboard.
Run	Run command channel	Three channels: operation panel given, control terminal given, serial communication port given. Switchable in a variety of ways
	Frequency source	There are 10 kinds of frequency sources: digital given, analog voltage given, analog current given, pulse given, serial port given. Switchable in a variety of ways
	Auxiliary frequency source	10 auxiliary frequency sources. Auxiliary frequency fine-tuning and frequency synthesis can be flexibly realized
	Input terminal	Standard five digital input terminals, up to ten digital input terminals (AI1, AI2 can be used as DI terminals), compatible with active PNP or NPN input mode Two analog input terminals, of which AI1 can only be used as voltage input, and AI2 can be used as voltage or current input. (If you need to expand the functions of input and output terminals, please choose an expansion card)
	Output terminal	Digital output terminal (bipolar output) Relay output terminal Analog output terminals, 0/4mA 20mA or 0/2V 10V can be selected respectively, which can realize the output of physical quantities such as set frequency, output frequency, speed, etc.

Technical Features		Description
Display and keyboard	LED Display	Display parameters
	LCD Display	Optional, Chinese/English prompt operation content
	LCD parameter copy	Fast replication of parameters using LCD
	Key lock and function selection	Part or all of the keys can be locked, and the scope of action of some keys can be defined to prevent misoperation
Protection and Options	Protective function	Power-on motor short-circuit detection, input and output phase loss protection, overcurrent protection, overvoltage protection, undervoltage protection, overheating protection, overload protection, etc.
	Optional accessories	LCD operation panel, brake assembly, etc.
State	Place of use	Indoor, no direct sunlight, no dust, corrosive gas, flammable gas, oil mist, water vapor, dripping water or salt, etc.
	Altitude	Below 1000 meters
	Ambient temperature	-10℃~+50℃ (Ambient temperature is 40℃~50℃, please use with derating)
	Humidity	Less than 95%RH, no condensation
	Vibration	Less than 5.9m/s <sup>2</sup> (0.6g)
	Storage temperature	-20℃~+60℃
	Pollution level	2
Product	Product implementation of safety standards	IEC61800-5-1:2007
	Products comply with EMC standards	IEC61800-3:2005

## 2.5 All components schematic diagram of AC drive

The following picture is all components and names of below 22KW plastic shell AC drive.



No.	Name	Description
①	Cabinet-cover	Protect the internal components.
②	Keypad	Refer to chapter4 "Keypad operating procedures."
③	Lower-cover	Protect the internal components.
④	Fan-cover	Protection fan.
⑤	Bottom Board	Inverter protection
⑥	Middle frame	Including Power Boards
⑦	Series Label	Refer to 2.3 "Naming Rules".
⑧	Dust prevention	To Prevent Dust
⑨	Screw Hole	To make VFD firm with screw

## 2.6 Appearance and installation dimensions

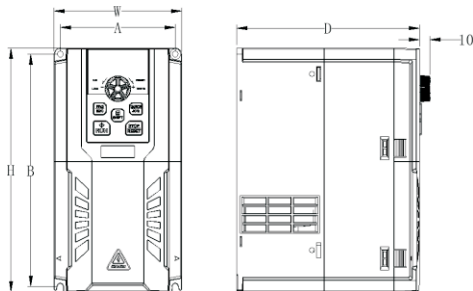

Schematic diagram of plastic dimensions and installation dimensions below 22KW

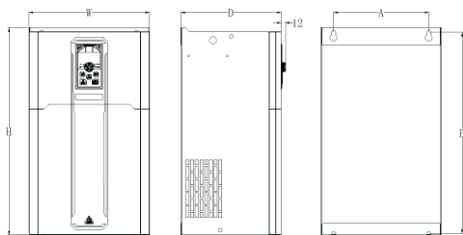

Schematic diagram of overall dimensions and installation dimensions of 30~132KW sheet metal chassis

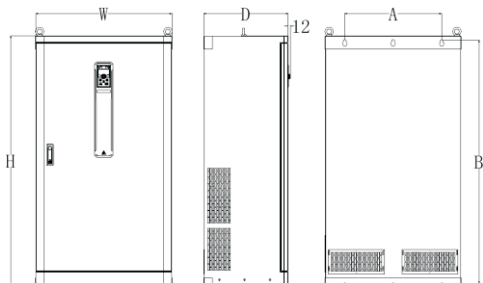

160KW Inverter Dimensions and Installation Dimensions

AC Drive Model	Adapter motor (KW)	Installation size(mm)		Dimensions (mm)			Aperture d
		A	B	H	W	D	
<b>Input voltage: single-phase 220V</b>		<b>Range : -15%~20%</b>					
KD600-2S-0.4G	0.4	64	138	148	74	130	4.5
KD600-2S-0.7G	0.75						
KD600-2S-1.5G	1.5	76	156	165	86	140	5
KD600-2S-2.2G	2.2						
<b>Input voltage: three-phase 380V</b>		<b>Range: -15%~20%</b>					
KD600-4T-0.7G/1.5P	0.7	76	156	165	86	140	5
KD600-4T-1.5G/2.2P	1.5						
KD600-4T-2.2G/4.0P	2.2						
KD600-4T-4.0G/5.5P	4.0	98	182	192	110	165	5
KD600-4T-5.5G/7.5P	5.5						
KD600-4T-7.5G/9.0P	7.5	111	223	234	123	176	6
KD600-4T-9.0G/11P	9.0						
KD600-4T-11G/15P	11	147	264	275	160	186	6
KD600-4T-15G/18.5P	15						
KD600-4T-18.5G/22P	18.5	174	319	330	189	186	6
KD600-4T-22G/30P	22						
KD600-4T-30G/37P	30	200	410	425	255	206	7
KD600-4T-37G/45P	37						
KD600-4T-45G/55P	45	245	518	534	310	258	10
KD600-4T-55G/75P	55						
KD600-4T-75G/90P	75	290	544	560	350	268	10
KD600-4T-90G/110P	90						
KD600-4T-110G/132P	110	320	678	695	410	295	10
KD600-4T-132G/160P	132						
KD600-4T-160G/185P	160	380	1025	1050	480	330	10
KD600-4T-185G/200P	185						
KD600-4T-200G/220P	200						
KD600-4T-220G/250P	220						
KD600-4T-250G/280P	250	500	1170	1200	590	365	14
KD600-4T-280G/315P	280						
KD600-4T-315G/350P	315	500	1255	1290	700	400	16
KD600-4T-350G/400P	350						
KD600-4T-400G/450P	400						

AC Drive Model	Adapter motor (KW)	Installation size(mm)		Dimensions (mm)			Aperture
		A	B	H	W	D	d
KD600-4T450G/500P	450	/	/	1800	1000	500	/
KD600-4T500G/550P	500						
KD600-4T550G/630P	550						
KD600-4T630G	630	/	/	2200	1200	600	/
KD600-4T710G	710						
KD600-4T800G	800						
<b>Input voltage: three-phase 700V</b>				<b>Range: -15%~20%</b>			
KD600-7T-030G	30	245	554	570	310	258	10
KD600-7T-037G	37						
KD600-7T-045G	45						
KD600-7T-055G	55						
KD600-7T-075G	75	220	705	725	350	275	10
KD600-7T-090G	90						
KD600-7T-110G	110						
KD600-7T-132G	132	320	815	835	440	295	10
KD600-7T-160G	160						
KD600-7T-185G	185						
KD600-7T-200G	200						
KD600-7T-220G	220						
KD600-7T-250G	250	380	1115	1140	550	330	12
KD600-7T-280G	280						
KD600-7T-315G	315						
KD600-7T-355G	355	500	1348	1380	700	400	14
KD600-7T-400G	400						
KD600-7T-450G	450						
KD600-7T-500G	500						
KD600-7T-550G	550	/	/	2200	800	600	/
KD600-7T-630G	630						
KD600-7T-710G	710						
KD600-7T-800G	800						

## 2.7 External keyboard with tray installation dimension drawing

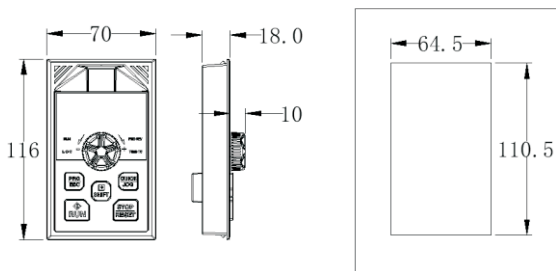

## 2.8 Optional accessories

For the detailed functions and usage instructions of the optional accessories, see the related optional accessories description.

If you need the above options, please specify when ordering.

Name	Model	Function	Remarks
Built-in braking unit	"B" after the product model number	For dynamic braking	Built-in braking unit is standard
	"(B)" after the product model number	For dynamic braking	Built-in braking unit is optional
External LED operation panel	KD600-LED	External LED display and operation keyboard	KD series general RJ45 interface
External LCD operation panel	KD600E-LCD	External LCD display and operating keyboard	KD series general RJ45 interface
External LED2 operation panel	KD600-LED2	External LED display and pure key keyboard	KD series general RJ45 interface
Keyboard gusset	KD600KB	When running without a keyboard or when the keyboard is externally drawn, using this keyboard gusset will have a good protective and aesthetic effect.	Optional
Extension cable	KD-CAB	Standard 8-core network cable, can be connected with KD600-LED, KD600-LCD, KD600-LED2	Available in 4 sizes: 1m, 3m, 5m and 10m
If other function modules are needed to expand functions (such as: I/O card, PG card, EPS card, etc.), please choose KD600 series expansion board, and specify the function module card when ordering.			

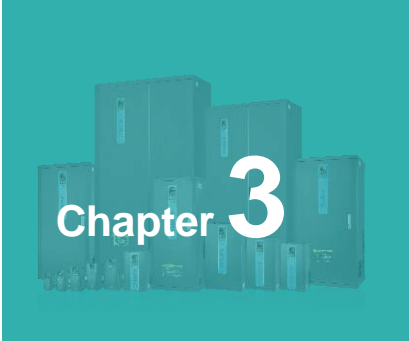

# Chapter 3

## Installation

---

3.1 Mechanical installation.....	24
3.2 Electrical Installation.....	28
3.3 Basic wiring diagram.....	31
3.4 Main circuit terminals and connection.....	33
3.5 Control circuit terminal and wiring.....	36
3.6 Treatment of EMC problem.....	41

## 3.1 Mechanical Installation

### 3.1.1 Installation Environment

- Environment temperature: Surrounding environment temperature has a great impact on lifetime of AC drive, and the operation environment temperature of AC drive shall not exceed allowable temperature range ( $-10^{\circ}\text{C} \sim 40^{\circ}\text{C}$ ).
- ⚠ AC drive is installed on the surface of inflammable retardants, and enough space around is necessary for heat dissipation. When AC drive works, it will produce plenty of heats. And make vertical installation onto supporting holder with screw.
- Install it in some places that are not easy to vibrate. And the vibration shall not be larger than 0.6G. Especially pay attention to keep away from punching machine and other equipments.
- ⚠ to be installed where there are direct sunlights, moist surroundings and water drops.
- ⚠ to be installed where there are corrosivity, inflammability and explosive gas.
- ⚠ to be installed where there are oil contamination, dirt and metal dusts.

### 3.1.2 Reminder of installation site

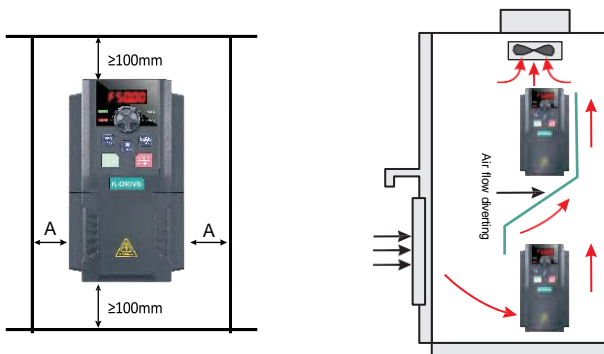

**Explanation:** When power of AC drives 22kw it means taking no account of size A is permissible. When the power  $> 22\text{KW}$ , A shall be larger than 50mm.

**Explanation:** When AC drive is installed upside and underside, please install thermal insulation guide plate as picture shows.

Figure 3-1 Installation diagram of AC drive

### 3.1.3 The installation of the model needs to pay attention to the problem of heat dissipation. So please note the following:

- install the inverter vertically so that the heat can be dissipated upwards. But not upside down. If there are many inverters in the cabinet, it is better to install them side by side. In the occasions that need to be installed up and down, please refer to Figure 3-1 to install the heat insulation deflector.
- installation space is as shown in Figure 3-1 to ensure the cooling space of the inverter. However, please consider the heat dissipation of other components in the cabinet when arranging.
- mounting bracket must be made of flame retardant material.
- applications with metal dust, it is recommended to install the radiator outside the cabinet. At this time, the space in the fully sealed cabinet should be as large as possible.

### 3.1.4 Mechanical installation methods and steps

installation structure	Installation Notes	instructions
Plastic structure through wall installation	<ul style="list-style-type: none"> <li>➤ Remove the bottom plate of the inverter;</li> <li>➤ Put the box into the cabinet with holes in the installation size, and fix it with M4x12 screws and M4 nuts;</li> <li>➤ Put the bottom plate back into the inverter;</li> </ul>	Figure 3-2
Sheet metal structure through wall installation	<ul style="list-style-type: none"> <li>➤ Use the flange type hanging angle to the upper and lower parts of the inverter body;</li> <li>➤ Put the inverter into the cabinet with the installation holes opened according to the size, and fix it with M6 screws and nuts;</li> </ul>	Figure 3-3

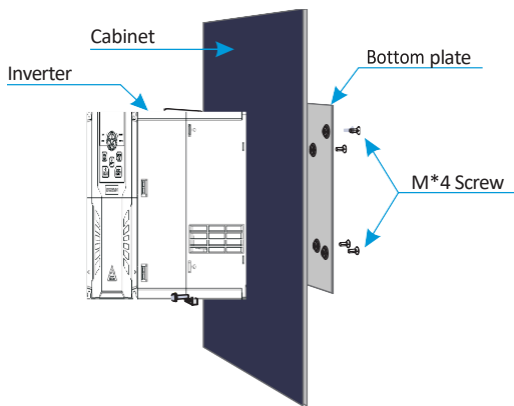

Figure 3-2 Plastic structure through wall installation drawing

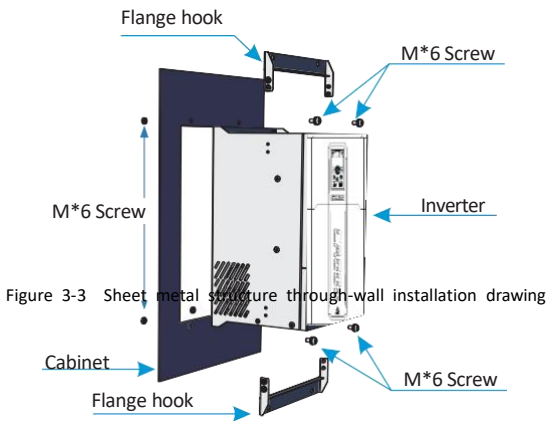
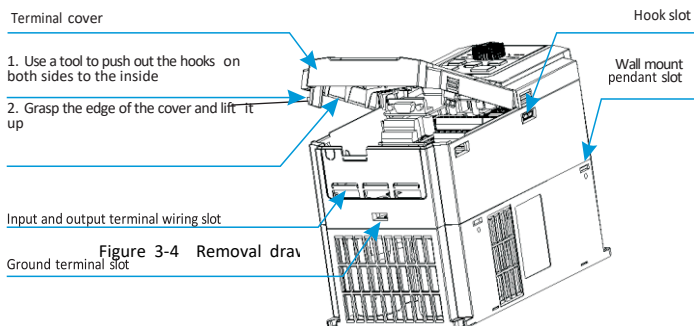

Figure 3-3 Sheet metal structure through-wall installation drawing

### 3.1.5 Terminal Cover Removal and Installation

KD600 series inverters use plastic casing. For the removal of the terminal cover of the plastic casing, see Figure 3-4. Use a tool to push the hook of the terminal cover to the inside and forcefully push it out.



## 3.2 Electrical Installation

### 3.2.1 Model Selection of Main Circuit Peripheral Devices

Models	MCCB (A)	Contact (A)	Cable of Input Side Main Circuit (mm <sup>2</sup> )	Cable of Output Side Main Circuit (mm <sup>2</sup> )	Cable of Control Circuit (mm <sup>2</sup> )
<b>Input 1PH 220V±15% 47Hz-63Hz</b>					
KD600-2S-0.5G-B	16	10	2.5	2.5	1.0
KD600-2S-0.7G-B	16	10	2.5	2.5	1.0
KD600-2S-1.5G-B	20	16	4.0	2.5	1.0
KD600-2S-2.2G-B	32	20	6.0	4.0	1.0
<b>Input 3PH 220V±15% 47Hz-63Hz</b>					
KD600-2T-0.5G-B	10	10	2.5	2.5	1.0
KD600-2T-0.75G-B	16	10	2.5	2.5	1.0
KD600-2T-1.5G-B	16	10	2.5	2.5	1.0
KD600-2T-2.2G-B	25	16	4.0	4.0	1.0
KD600-2T-3.7G-B	32	25	4.0	4.0	1.0
KD600-2T-5.5G-B	63	40	4.0	4.0	1.0
KD600-2T-7.5G-B	63	40	6.0	6.0	1.0
KD600-2T-11G-B	100	63	10	10	1.0
KD600-2T-15G-B	125	100	16	10	1.0
KD600-2T-18.5G-B	160	100	16	16	1.0
KD600-2T-22G-B	200	125	25	25	1.0
KD600-2T-30G	200	125	35	25	1.0
KD600-2T-37G	250	160	50	35	1.0
KD600-2T-45G	250	160	70	35	1.0
KD600-2T-55G	350	350	120	120	1.0
KD600-2T-75G	500	400	185	185	1.0
<b>Input 3PH 380V±15% 47Hz-63Hz</b>					
KD600-4T-0.75G/1.5P	10	10	2.5	2.5	1.0
KD600-4T-1.5G/2.2P	16	10	2.5	2.5	1.0
KD600-4T-2.2G/3.7P	16	10	2.5	2.5	1.0
KD600-4T-3.7G/5.5P	25	16	4.0	4.0	1.0
KD600-4T-5.5G/7.5P	32	25	4.0	4.0	1.0
KD600-4T-7.5G/11P	40	32	4.0	4.0	1.0
KD600-4T-11G/15P	63	40	4.0	4.0	1.0
KD600-4T-15G/18.5P	63	40	6.0	6.0	1.0

Models	MCCB (A)	Contactor (A)	Cable of Input Side Main Circuit (mm <sup>2</sup> )	Cable of Output Side Main Circuit (mm <sup>2</sup> )	Cable of Control Circuit (mm <sup>2</sup> )
<b>Input 3PH 380V±15% 47Hz-63Hz</b>					
KD600-4T-18.5G/22P	100	63	6	6	1.0
KD600-4T-22G/30P	100	63	10	10	1.0
KD600-4T-30G/37P	125	100	16	10	1.0
KD600-4T-37G/45P	160	100	16	16	1.0
KD600-4T-45G/55P	200	125	25	25	1.0
KD600-4T-55G/75P	250	125	35	25	1.0
KD600-4T-75G/93P	250	160	50	35	1.0
KD600-4T-15G/18.5P	350	160	70	35	1.0
KD600-4T-93G/110P	350	350	120	120	1.0
KD600-4T-110G/132P	400	400	150	150	1.0
KD600-4T-132G/160P	500	400	185	185	1.0
KD600-4T-160G/200P	500	400	185	185	1.0
KD600-4T-200G/220P	630	600	150*2	150*2	1.0
KD600-4T-220G/250P	630	600	150*2	150*2	1.0
KD600-4T-250G/280P	800	600	150*2	150*2	1.0
KD600-4T-280G/315P	800	800	150*2	150*2	1.0
KD600-4T-315G/350P	1000	800	150*3	150*3	1.0
KD600-4T-350G/400P	1000	800	150*4	150*4	1.0
KD600-4T-400G/500P	1200	1000	150*4	150*4	1.0
KD600-4T-500G/630P	1200	1000	150*4	150*4	1.0
KD600-4T-630G	1200	1000	150*4	150*4	1.0

### 3.2.2 Peripheral device wiring diagram

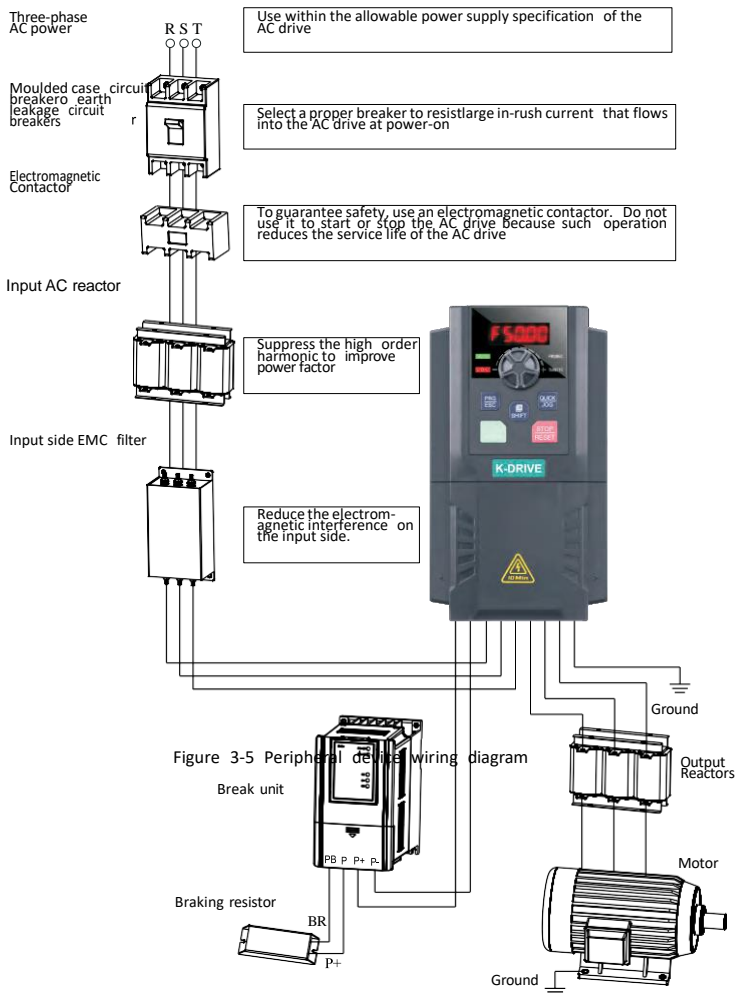

## 3.3 Basic wiring diagram

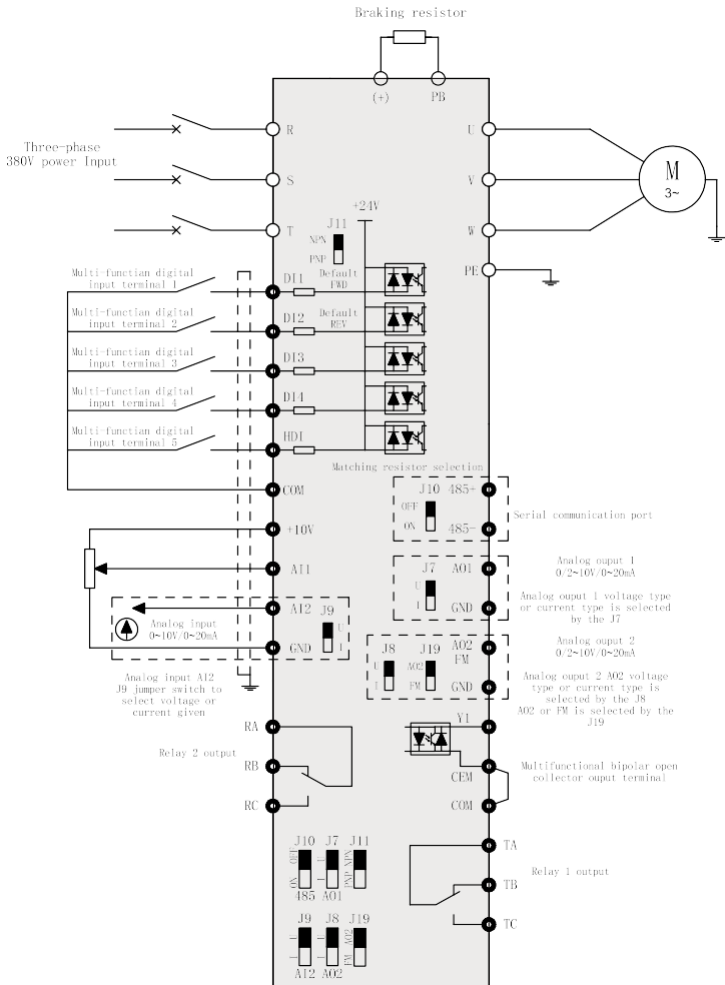

Figure 3-6 Three-phase inverter below 2.2kW

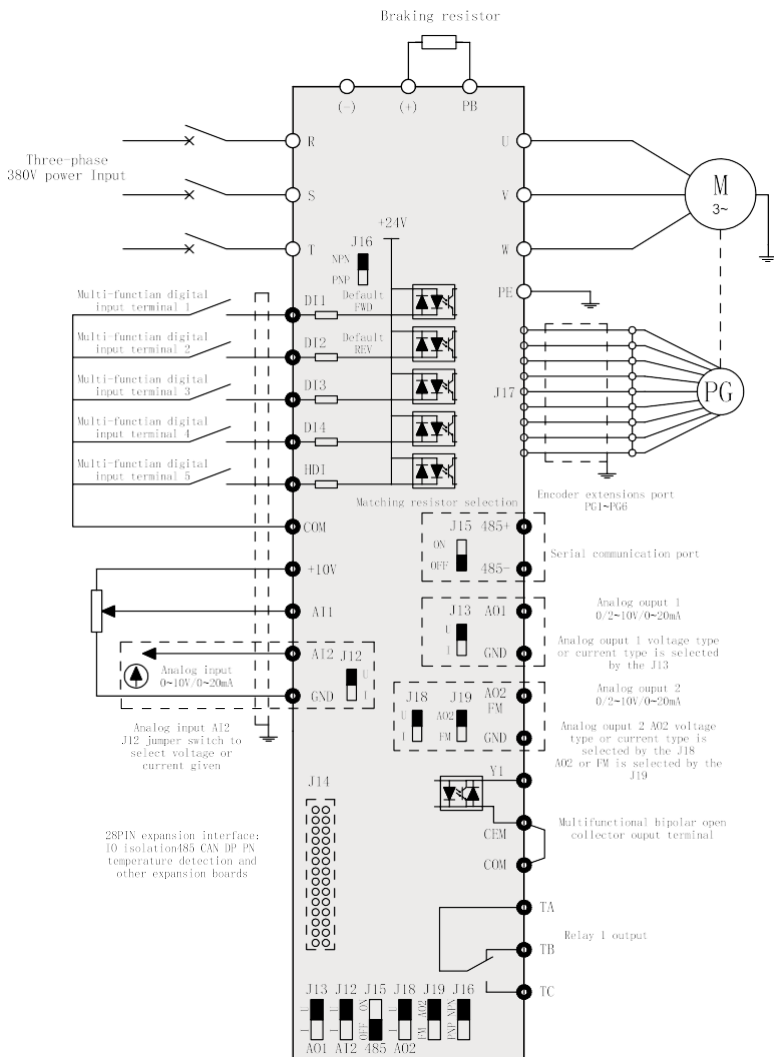

Figure 3-7 (4T/7T) Three-phase inverter above 4.0kW

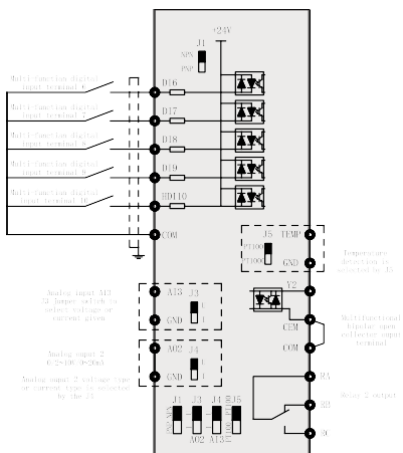

Figure 3-8 KD600-IO1 expansion card

**Note:**

Parts above 4KW of the KD600 series are optional functions. If you need it, please specify when ordering.

### 3.4 Wiring (For LCD panel)

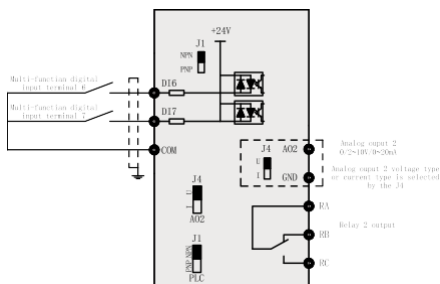

Figure 3-9 LCD panel dedicated expansion card wiring diagram

**Note:**

Parts above 4KW of KD600 series are optional functions. Upgrade the control board to a RJ45 interface board with 485 communication. You can freely choose LED or LCD keyboard, without the need for additional IO cards. If you need it, please specify when ordering.

## 3.4.1 Control terminals and wiring

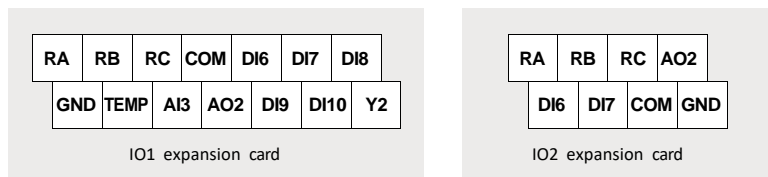

Figure 3-10 Three-phase 380V/660V 4.0KW above expansion card control terminal

## 3.4.2 KD600 inverter control terminal function description

Sort	Terminal	Name	Function Description
Power supply	+10V-GND	External +10V power supply	Provide +10V power supply to the outside, the maximum output current: 10mA Generally used as working power supply of external potentiometer, potentiometer resistance range: 1~5kΩ
	24V-COM	External +24V power supply	Provide +24V power supply to the outside, generally used as the working power supply of digital input and output terminals and external sensor power supply, Maximum output current: 200mA
Analog input	AI1-GND	Analog input terminal 1	1. Input voltage range: DC0~10V 2. Input impedance: 100KΩ
	AI2-GND	Analog input terminal 2	1. Input range: DC0~10V/4~20mA, determined by the J12 DIP switch on the control board, the factory is voltage mode.
	AI3-GND	Analog input terminal 3	2. Input impedance: 100kΩ for voltage input, 500Ω for current input. (Optional accessories: IO1 supports AI3 function)
Digital input	DI1-COM	Digital input 1	1. Optical coupling isolation, compatible with bipolar input, switch by DI DIP switch, the factory is NPN mode
	DI2-COM	Digital input 2	
	DI3-COM	Digital input 3	2. Input impedance: 3.3kΩ
	DI4-COM	Digital input 4	3. Voltage range for level input: 9~30V
	DI5-COM	Digital input 5	4. HDI5 can be used as high-speed input port, the maximum input frequency is 50KHz

Sort	Terminal	Name	Function Description
Digital input	DI6-COM	Digital input 6	(Optional accessories: IO2 card supports DI6, DI7 expansion; IO1 card supports DI6, DI7, DI8, DI9, DI10 expansion.)
	DI7-COM	Digital input 7	
	DI8-COM	Digital input 8	
	DI9-COM	Digital input 9	
	DI10-COM	Digital input 10	
Analog output	AO1-GND	Analog output 1	The voltage or current output is determined by the DIP switch on the control board (refer to the bit number of the terminal wiring diagram). (Optional accessories: IO1, IO2 support AO2 function)
	AO2-GND	Analog output 2	Output voltage range: 0~10V Output current range: 0~20mA
Digital output	Y1-CME	Digital output 1	Optocoupler isolation, bipolar open collector output Output voltage range: 0~24V Output current range: 0~50mA Note: The digital output ground CME and the digital input ground COM are internally isolated, but the CME and COM have been externally short-circuited at the factory (the Y terminal is driven by +24V by default). When the Y terminal is to be driven by an external power supply, the external short connection between CME and COM must be disconnected. (Optional accessories: IO2 supports Y2 function)
	Y2-CME	Digital output 2	
	FM	High-speed pulse output	Programmable optocoupler isolation, open collector output The highest frequency: 50KHz; when the collector is open-circuit output, it is consistent with the Y1 specification. Output voltage range: 0/24VDC, output current range: 50mA

Sort	Terminal	Name	Function Description
Communication Interface	485+, 485-	Modbus communication interface	Modbus communication interface, you can choose whether to need communication matching resistance through the DIP switch (refer to the bit number of the terminal wiring diagram). If Profibus communication function is required, please select KD600 series expansion card and Profibus DP card.
Relay output 1	TA-TB	Normally closed terminal	Contact drive capability: AC250V, 3A, $\text{COS}\phi=0.4$ . DC30V, 1A
	TA-TC	Normally open terminal	
Relay output 2	RA-RB	Normally closed terminal	Contact drive capability:(Optional accessories: IO1, IO2 support function) AC250V, 3A, $\text{COS}\phi=0.4$ . DC30V, 1A
	RA-RC	Normally open terminal	
Keyboard extension cable interface	Control board RJ45 interface	External keyboard interface	External keyboard interface, can use standard network cable for external extension.

## 3.5 Main circuit terminals and connection

### 3.5.1 Main circuit terminal description

Single-phase inverter main circuit terminal description		
Terminal	Name	Function description
L, N	Single-phase power input terminal	Single-phase 220V AC power connection point
P(+), (-)	DC bus positive and negative terminals	Common DC bus input point
P(+), PB	Braking resistor connection terminal	Connect the braking resistor
U, V, W	Inverter output terminal	Connecting a three-phase motor
	Ground terminal	Ground terminal

Three-phase inverter main circuit terminal description		
Terminal	Name	Function description
R, S, T	Three-phase power input terminal	AC input three-phase power connection point
P(+), (-)	DC bus positive and negative terminals	Common DC bus input point
P(+), PB	Braking resistor connection terminal	Connect the braking resistor
U, V, W	Inverter output terminal	Connecting a three-phase motor
	Ground terminal	Ground terminal

### 3.5.2 Wiring Precautions



#### DANGER

- ~~On~~ power switch stays in the state of OFF and then start wiring operation or it will give rise to electric shock hazard!
- ~~Work~~ personnel must be those professional trainees or it will cause equipment damages and personal injuries!
- ~~The~~ ground connection is necessary or it will give rise to electric shock or fire alarm!
- ~~On~~ the input power is in accordance with the rated value of AC drive, or it will cause damages to AC drive!
- ~~On~~ motor is adaptive with AC drive or it will cause damages to motor or cause AC drive protection!
- ~~Supply~~ shall not be connected to the terminals of U, V and W, or it will cause damages to AC drive!
- ~~Resistance~~ shall not be connected directly to DC bus + 2, - or it will cause damages to AC drive!

### 3.5.3 Attentions of wiring

#### A. Input power L, N or R, S and T:

The connection of inverter input side has no phase sequence requirements.

#### B. DC bus $\oplus 2$ , $\ominus$ terminals:

At the moment of power failure, DC bus + 2  $\ominus$  terminals still have residual voltage, you just can touch it after internal "charge" power light is off confirming the voltage is less than 36V, it may cause electric shock.

When you select external brake unit for AC drive  $\geq 30\text{KW}$ , the polarity of + 2 and  $\ominus$  cannot be  $\ominus$  connected inversely or it will cause damages to AC drive, or even fire hazard.

The wiring length of brake unit shall not be more than 10m, and only twisted pair or tight double-line is available in parallel.

Brake resistance cannot be connected onto DC bus directly, or it may cause damages to AC drive, or even fire hazard.

#### C. Brake resistance connection terminal (+) and PB:

AC drive  $\leq 22\text{KW}$  and built-in brake unit.

The recommended value of brake resistance model selection reference and wiring distance shall be less than 5m, or it may cause damages to AC drive.

#### D. AC drive output side U, V and W:

AC drive output side shall not be connected to capacitor or surge absorber, or it will frequent protection of AC drive, or even damages.

When the cable of motor is overlong, the effects of distributed capacitance will generate electric resonance easily, and give rise to dielectric breakdown of motor.

The generated large leakage current makes AC drive suffer overcurrent protection. If cable length is more than 100m, alternating current output reactor shall be installed.

#### E. Grounding terminal $\oplus$ :

Terminals must have been reliable ground connection, and resistance value of ground wire shall be less than  $4\Omega$ , or it will cause abnormal work of equipment, and even damages.

Grounding terminal  $\oplus$  and null line N terminal of power supply cannot be shared.

## 3.6 Control circuit terminal and wiring

### 3.6.1 Schematic diagram of control circuit wiring terminal

GND	AO1	485-	DI1	DI2	DI3	DI4	HDI5	+24V	RA	RB	RC
+10V	AI1	AI2	485+	CME	COM	Y1	AO2 FM	COM	TA	TB	TC

Figure 3-9 Three-phase 220V/380V below 2.2 KW

+10V	AI1	AI2	DI1	DI2	DI3	DI4	HDI	T/A	T/B	T/C
GND	GND	AO1	485+	485-	CME	COM	Y1	AO2 FM	COM	+24V

Figure 3-10 Three-phase 380V/660V 4.0KW or more

### 3.6.2 Control terminal function description

Sort	Terminal	Name	Function Description
Power supply	+10V-GND	External +10V power supply	Provide +10V power supply to the outside, the maximum output current: 10mA Generally used as working power supply of external potentiometer, potentiometer resistance range: 1~5kΩ
	24V-COM	External +24V power supply	Provide +24V power supply to the outside, generally used as the working power supply of digital input and output terminals and external sensor power supply, Maximum output current: 200mA

Sort	Terminal	Name	Function Description
Analog input	AI1-GND	Analog input terminal 1	1. Input voltage range: DC0~10V 2. Input impedance: 100KΩ
	AI2-GND	Analog input terminal 2	1. Input range: DC0~10V/4~20mA, determined by the J12 DIP switch on the control board, the factory is voltage mode. 2. Input impedance: 100kΩ for voltage input, 500Ω for current input.
Digital input	DI1-COM	Digital input 1	1. Optical coupling isolation, compatible with bipolar input, switch by DI DIP switch, the factory is NPN mode 2. Input impedance: 3.3kΩ 3. Voltage range for level input: 9~30V 4. HDI5 can be used as high-speed input port, the maximum input frequency is 50KHz 5. DI6~DI10 are expansion board interfaces.
	DI2-COM	Digital input 2	
	DI3-COM	Digital input 3	
	DI4-COM	Digital input 4	
	DI5-COM	Digital input 5	
	DI6-COM	Digital input 6	
	DI7-COM	Digital input 7	
	DI8-COM	Digital input 8	
	DI9-COM	Digital input 9	
	DI10-COM	Digital input 10	
Analog output	AO1-GND	Analog output 1	The voltage or current output is determined by the DIP switch on the control board (refer to the bit number of the terminal wiring diagram).
	AO2-GND	Analog output 2	Output voltage range: 0~10V Output current range: 0~20mA
Digital output	Y1-CME	Digital output 1	Optocoupler isolation, bipolar open collector output Output voltage range: 0~24V Output current range: 0~50mA Note: The digital output ground CME and the digital input ground COM are internally isolated, but the CME and COM have been externally short-circuited before leaving the factory (in this case, Y1 is driven by +24V by default). When Y1 wants to drive with an external power supply, the external short connection between CME and COM must be disconnected.

Sort	Terminal	Name	Function Description
Digital output	FM (optional Y2)	High-speed pulse output	Analog voltage/current input, Choose voltage or current input by Setting JP3 jumper. Factory default: voltage input (Grounding: GND)
Communication Interface	485+, 485-	Modbus communication interface	Modbus communication interface, you can choose whether to need communication matching resistance through the DIP switch (refer to the bit number of the terminal wiring diagram). If Profibus communication function is required, please select KD600 series expansion card and Profibus DP card.
Relay output 1	TA-TB	Normally closed terminal	Contact drive capability: AC250V, 3A, $\text{COS}\phi=0.4$ . DC30V, 1A
	TA-TC	Normally open terminal	
Relay output 2	RA-RB	Normally closed terminal	Contact drive capability: AC250V, 3A, $\text{COS}\phi=0.4$ . DC30V, 1A
	RA-RC	Normally open terminal	
Keyboard extension cable interface	Control board RJ45 interface	External keyboard interface	External keyboard interface, can use standard network cable for external extension.

### 3.6.3 Signal input terminal wiring instructions:

#### A. AI analog input terminal:

Because weak analog voltage signals are particularly susceptible to external interference, shielded cables are generally required, and the wiring distance should be as short as possible, not exceeding 20m, as shown in Figure 3-12. In some occasions where the analog signal is severely interfered, a filter capacitor or a ferrite core should be added on the analog signal source side.

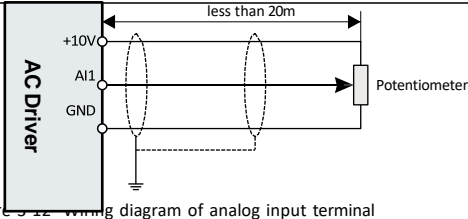

Figure 3-12 Wiring diagram of analog input terminal

At some occasion where analog signal suffers severe interference, filter condenser or ferrite core shall be installed at the side of analog signal source, as Figure 3-13 shows:

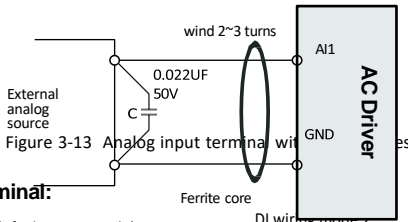
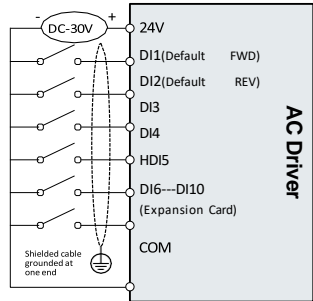
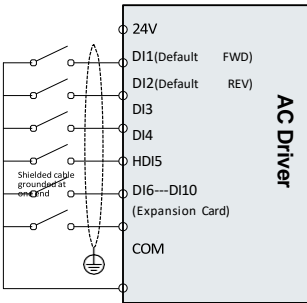

Figure 3-13 Analog input terminal wiring

**B. Digital input terminal:**

DI wiring mode 1 (factory default wiring mode):  
When the DI DIP switch is in NPN mode, no external power supply is used

DI wiring mode 2:  
Use an external power supply when the DI DIP switch is in NPN mode



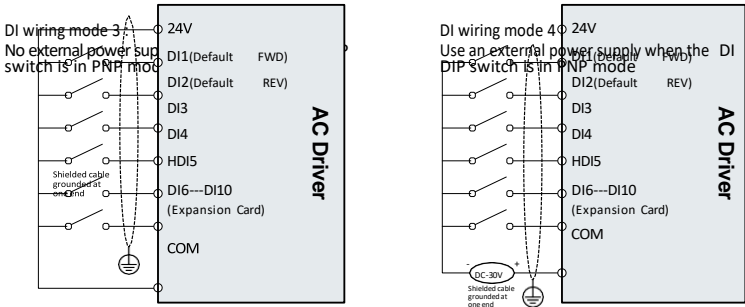
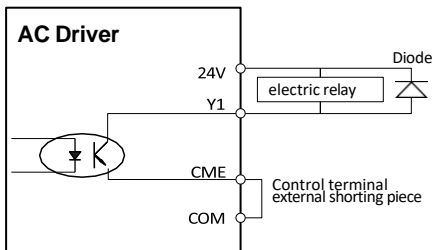

Figure 3-14 Wiring diagram of digital input terminals in four different modes

### C. Y1 digital output terminal:

When the digital output terminal needs to drive the relay, an absorption diode should be installed on both sides of the relay coil, and the driving capacity is not more than 50mA. Otherwise, it is easy to cause damage to the DC 24V power supply.

Note: The polarity of the absorption diode must be installed correctly, as shown in Figure 3-15, otherwise when the digital output terminal has output, the DC 24V power supply will be burned out immediately.



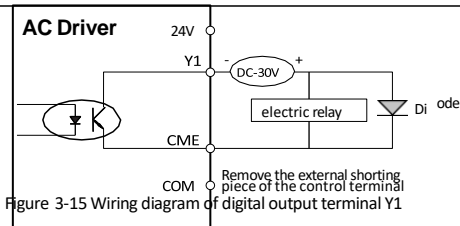

## 3.7 Treatment of EMC problem

### 3.7.1 Effects of harmonic wave

- ✎ harmonic wave of power supply will cause damages to inverter. So in some places with bad power grid quality, we advise to install AC input reactor.
- ✎ higher harmonic wave exists at the output side of AC drive, the application of capacitor to improve power factor and surge suppressor at output side may lead to electric shock, or even damages to equipment, so capacitor or surge suppression device cannot be installed at output side.

### 3.7.2 Electromagnetic interference and treatment

- ① Electromagnetic interference has two categories: One is peripheral magnetic noise's interference on AC drive, which will give rise to false operations of inverter itself. But the effects of such interference usually are small, because AC drive has been processed internally in design about this interference, and it has a strong anti-interference capability. The other one is AC drive's effects on peripheral equipments.
  - ✎ drive and other electrical products should ground well, and the ground resistance shall not more than  $4\Omega$ .
  - ✎ will be better if power line of AC drive won't be placed in parallel with circuit of control line. If condition permission, please arrange power lines vertically.
  - ✎ Those occasions with a high anti-interference requirement, shield cable shall be used between AC drive and power line of motor, and reliable ground connection also is necessary for shielding layer.

② methods of interference from peripheral electromagnetic equipment on AC drive. Electromagnetic effects on inverter generally result from the installation of many relays, contactors or electromagnetic contactors near AC drive. When AC drive has false operation from the interference, please try to solve it with following methods:

➤ surge suppressor on the devices that make interference;

➤ filter at signal input terminal of AC drive;

➤ leading wire of AC drive's control signal line and detection circuit shall be shield cable, and reliable ground connection also is necessary for shielding layer.

③ The handling methods of interference on peripheral equipments from noises of AC drive:

This part of noise can be divided into two categories: One is the radiation of AC drive itself, and the other one is the radiation of the leading wire from inverter to motor.

These two kinds of radiations make the leading wires surface of peripheral electrical equipments suffer electromagnetic and electrostatic induction, which will lead to false operations of equipments. About these several different disturbed conditions, please refer to following methods to resolve them:

➤ Receiver, sensor and other equipment for measurement, generally have a weaker signal. If they are placed near AC drive or in a same control cabinet, they will suffer interference and operate falsely. So we advise to take following methods: Keep away from interference source; Signal line shall not be placed with power line in parallel, especially shall not be tied up together in parallel, and please adopt shield cable signal line and power line; Install linear filter or radio noise filter at the input and output sides of AC drive.

➤ Interrupted equipments and AC drive share a same power supply, if above methods still cannot help to eliminate interference, you shall install linear filter or radio noise filter between AC drive and power supply.

- ✘ ground connection for peripheral equipments can help to eliminate the interference from ground wires' leakage current of AC drive while common grounding.

### 3.7.3 Leakage current and treatment

Leakage current has two categories when inverter is in service: One is leakage current over the ground: and the other is leakage current between lines.

- 1 Factors of influencing leakage current over the ground and solutions: Distributed capacitances exist between wire and ground. The larger distributed capacitances are, the larger the leakage current will be: Effectively decreasing the distance between AC drive and motor can reduce distributed capacitances. The larger carrier frequency is, the larger the leakage current will be. Reducing carrier frequency can decrease leakage current effectively. But reducing carrier frequency will result in the increase of motor noise, so please note this. Installing electric reactor also is an effective method to solve leakage current.

Leakage current will increase with enlargement of loop current, so when the power of motor is large, the relevant leakage current also will be large.

- 2 Factors of influencing electric current between lines and solutions: Distributed capacitances exist between output wires of AC drive. If the electric current passing the circuit contains higher harmonic, it may give rise to resonance and leakage current. If you use thermal relay, it may cause false operation at this time.

The solution is to decrease carrier frequency or install output reactor. We advise not to install thermal relay before you use the motor of AC drive, but apply the electronic overcurrent protection function of AC drive.



# Chapter 4

---

## Operation and Display

4.1 Keypad description. ....	46
4.2 Organization of Inverter Function Codes. ....	48
4.3 Function code viewing and modification method description. ....	48
4.4 Function code menu mode and switching instructions. ....	49
4.5 Preparation before running. ....	52
4.6 Start-stop control of inverter. ....	56
4.7 Frequency converter operating frequency control. ....	62
4.8 Motor characteristic parameter setting and automatic tuning. ....	70
4.9 How to use the DI port of the inverter. ....	72
4.10 How to use the DO port of the inverter. ....	73
4.11 AI input signal characteristics and preprocessing. ....	74

## 4.1 Keypad description

### 4.1.1 Keypad explanation and function

Using the operation panel, you can modify the function parameters of the inverter, monitor the working status of the inverter, and control the operation of the inverter (start, stop). Its appearance and functions are shown in the following figure.

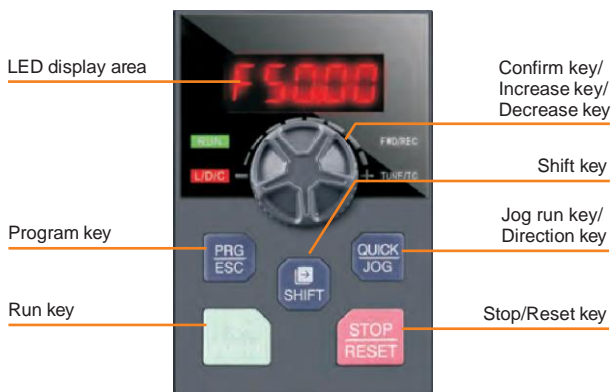

Figure 4-1 Operation panel diagram 1  
(standard configuration LED keyboard 1)

### 4.1.2 Function indicator description







Indicator sign	Name	meaning	Color
RUN	Operating status indicator	On - the inverter is running Off - Inverter is in stop state Flashing - the inverter is in sleep state	Green
L/D/C	Control mode indicator	Off - Inverter is in keypad control mode On - the inverter is in terminal control mode Flashing - Inverter is in remote communication control mode	Red
FWD/REV	Running direction indication	Off - Forward state On - inversion state Flashing - the target frequency is opposite to the actual frequency or is in the reverse running prohibited state	Red
TUNE/TC	Tuning/Torque Control/Fault Indicator	On - torque control Flashing - Tuning\Fault status	Red

### 4.1.3 Digital display area

5-digit LED display can display the set frequency, output frequency, various monitoring data and alarm codes. The function code is usually displayed as a decimal number. For example, the value of the P0-11 function code is displayed as "50.00", which means the decimal number "50.00". When the function code value is displayed in hexadecimal, the highest digit of the nixie tube displays "H.", indicating that the current function code value is displayed in hexadecimal. For example, the value of the P7-29 function code is displayed as "H. At this time, the value of P7-29 is the hexadecimal number "0x3f".

The user can freely set the monitoring data of stop and running status according to function code P7-29/P7-30, see function code P7-29/P7-30 for details.

### 4.1.4 Description of keyboard buttons

Button	Name	Function Description
	Program / Escape key	Enter or exit the first-level menu, return to the upper-level menu
	Enter	Enter the menu screen step by step, set parameters to confirm
	Increment key (+)	Increment of data or function code
	Decrement key (-)	Decrement of data or function code
	Shift key	In the stop display interface and the running display interface, the display parameters can be selected cyclically. For the specific display meaning, please refer to P7-29 and P7-30; when modifying the parameters, you can select the modification bit of the parameter
	Run key	In keyboard operation mode, used to run operation
	Stop/Reset key	In the running state, pressing this key can be used to stop the running operation; in the fault alarm state, it can be used to reset the operation. The characteristics of this key are restricted by the function code P7-27.
	Jog run/Direction keys	When P7-28 is set to 0, it is the jog running button, and when P7-28 is set to 1, it is the direction button. Press this button to reverse the direction.

## 4.2 Organization of Inverter Function Codes

Function code group	Function description	Illustrate
P0~PF	Basic function parameter group	Compatible with KD600 series function codes
A0~A3	Second motor parameter group	The second motor parameters, acceleration and deceleration time, control mode, etc. can be set independently
B0~B6	Enhanced function parameter group	System parameter setting, user function code customization, optimization control, AI/AO correction, master-slave control, brake function and sleep function;
C0~CF	Special plane function selection group	Choose to use different professional inverter functions;
U0~U1	Monitoring parameter group	U0 is the fault record parameter group, and U1 is the user monitoring parameter, which is convenient to check the relevant output status;

## 4.3 Function code viewing and modification method description

AC drives adopts three-level menu structure for parameter setting and other operations. The three-level menus respectively are: functional parameter group (first-level menu) → function code (second-level menu) → function code setting value (third-level menu). Operational process is shown in Figure 4-2:

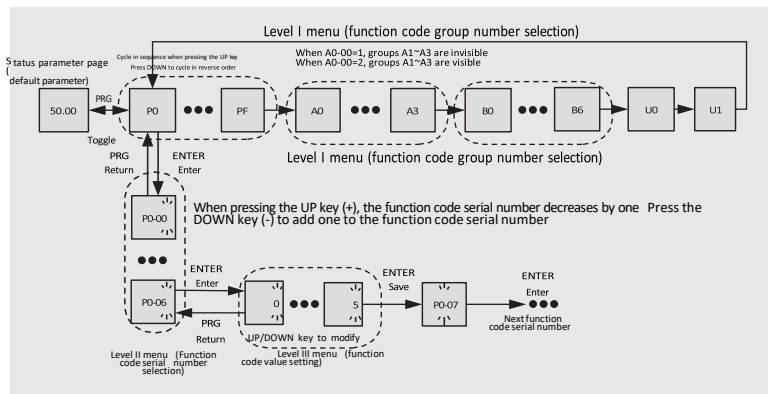

Figure 4-2 Three-level menu operation flow chart

**Note:**

When operating in the third-level menu, you can press PRG key or ENTER key to return to the second-level menu. But pressing the ENTER key will save the current parameter modification value and transfer to the next function code; while pressing the PRG key will abandon the current parameter modification.

Example: Change function code P1-04 from 0.00Hz to 5.00Hz.

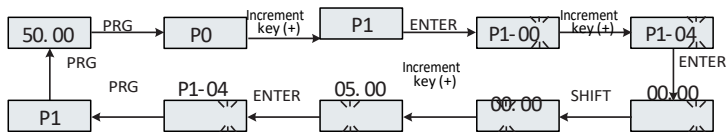

Figure 4-3 Parameter setting operation flow chart

In the third-level menu state, if the parameter has no flashing bit, it means that the parameter value of the function code cannot be modified. For the specific reason, please refer to the description of the function code attribute.

## 4.4 Function code menu mode and switching instructions

### 4.4.1 Definition and operation of multi-function shortcut keys

The function of QUICK/JOG button can be defined by P7-28 function code.

		Quick/Jog key function selection		Factory default	0
P7-28	Predetermined area	0	Forward jog		
		1	Forward and reverse switching		
		2	Reverse jog		
		3	Switch between panel control and remote control (terminal or communication)		

The Quick/Jog key is a multi-function key, and the function of the Quick/Jog key can be set through this function code. This key can be used to switch between stop and running.

#### 0: Forward jog

Forward jog (FJOG) is realized through the keyboard Quick/Jog key.

**1: Forward and reverse switching,**

Use the Quick/Jog key to switch the direction of the frequency command. This function is only valid when the command source is the command channel of the operation panel.

**2: Reverse jog**

Reverse jog (RJOG) is realized through the keyboard Quick/Jog key.

**3: Switch between panel control and remote control (terminal or communication)**

Refers to the switching of the command source, that is, the switching between the current command source and keyboard control (local operation). If the current command source is keyboard control, the function of this key is invalid.

**4.4.2 Function code menu mode**

In order to facilitate users to view and operate, KD600 series inverters provide three menu modes of function codes to switch and display.

Menu mode	Describe
-BASE Basic menu mode	Display the function code parameters in sequence, P0~PF, A0~A3, B0~B6, C0~CF, U0~U1- Among them, A1~A3 will only be displayed when it is the second motor, and the display of C1~CF is related to the parameter setting of C0-00, and it is not displayed by default.
-USER User-defined parameter mode	Only display user-customized function parameters (up to 31 customized), which can be freely defined through group B1- The function code starts with the letter U, and the parameter value of the function code can be directly modified.  The inverter has already defined 19 commonly used user function codes for the user. At the same time, the user can clear the user-defined function codes through B1-00, and then redefine B1-01 to B1-31.
-NOTF Factory value change parameter mode	After entering this menu mode, only the function codes that are inconsistent with the factory parameters will be displayed. The function codes start with the letter n.

Group B1 Factory Customized User Function Codes

Function code	Factory Default	Name	Function code	Factory Default	Name
B1-00	0	Clear Custom Feature Selection	B1-10	uP4-05	Motor 1 rated frequency
B1-01	uP0-03	control method	B1-11	uP4-06	Motor 1 rated speed
B1-02	uP0-04	command source	B1-12	uP4-12	Acceleration at Dynamic Full Tuning
B1-03	uP0-06	Main frequency source X selection	B1-13	uP4-13	Deceleration at dynamic full tuning
B1-04	uP0-23	Acceleration time 1	B1-14	uP5-00	DI1 terminal function selection
B1-05	uP0-24	Deceleration time 1	B1-15	uP5-01	DI2 terminal function selection
B1-06	uP4-00	Motor 1 tuning selection	B1-16	uP5-02	DI3 terminal function selection
B1-07	uP4-01	Motor 1 rated power	B1-17	uP6-00	Relay Relay1 output selection
B1-08	uP4-02	Motor 1 rated voltage	B1-18	uP6-01	Relay Relay2 output selection
B1-09	uP4-04	Motor 1 rated current	B1-19	uP6-02	Y1 output selection

#### 4.4.3 Function code menu mode switch

The inverter is in the -BASE basic menu mode by default. When the user needs to switch the menu mode, press and hold the ENTER key for 3s in the status parameter interface to switch the menu mode. After the switch is successful, the current menu mode (-BASE\USER\NOTF) will be displayed. ) for 3s, and then return to the status parameter interface. At this time, you can view and set the function codes in the current menu mode. For the specific process, see Figure 4-4 below.

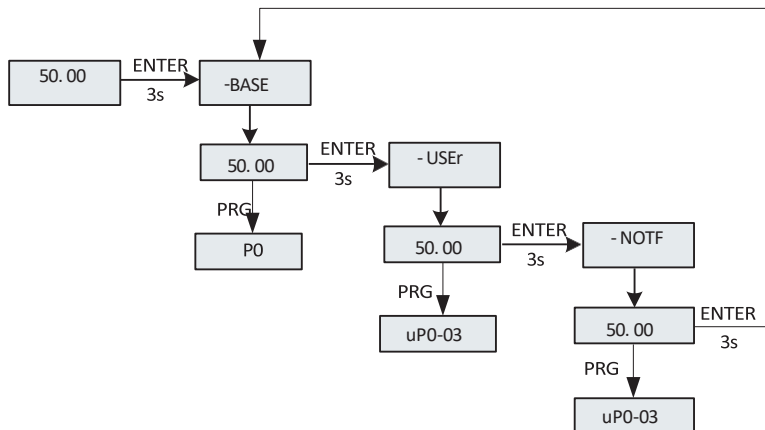

Figure 4-4 Schematic diagram of menu mode switching operation

## 4.5 Preparation before running

### 4.5.1 User-defined function code settings

19 commonly used parameters have been stored in the custom menu when leaving the factory, as shown in Table 4-1. The user can also clear the factory customized function code by B1-00=1, or re-customize the user function code for B1-00~B1-31. The switching operation between menu modes can be performed as described in Section 4.4.3.

### 4.5.2 Runtime steps

The flowchart in this section introduces the basic steps required before starting the inverter. Please refer to the corresponding flowchart according to the specific application of the inverter. This section describes only the basic settings.

Flow Chart	Subflow Diagram	Purpose
A	-	Basic steps from installation, wiring to operation
-	A-1	Operation in open loop vector (speed sensorless vector) control mode
-	A-2	Operation in V/F Control Mode

### ● Flowchart A (Motor connected operation with minimum setting changes)

Flowchart A illustrates the operation of connecting the motor with minimal setting changes. Depending on the application, the settings may vary slightly. In applications that do not require high-precision control, please use the inverter's initial setting parameters.

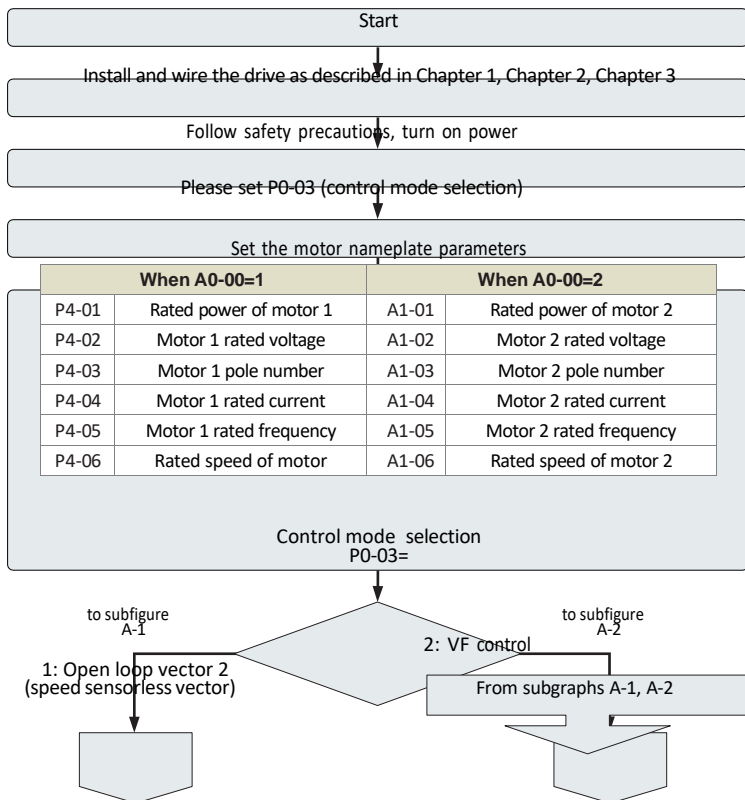

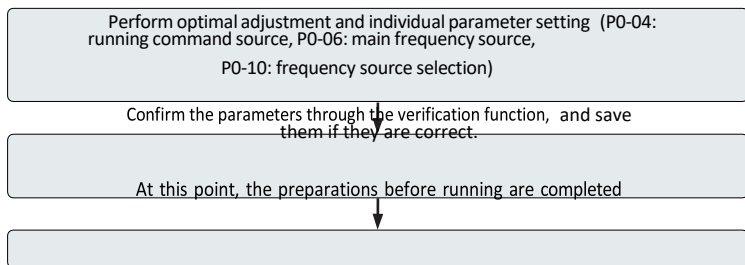
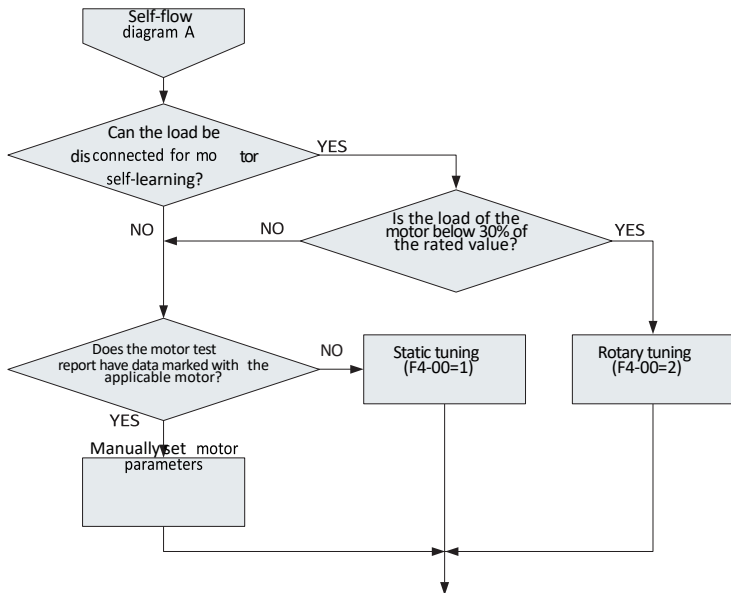

Figure 4-5 Basic steps before running

② Sub-flowchart A-1 (motor running in open-loop vector control mode)

Sub-flowchart A-1 describes the start-up procedure for open-loop vector (velocity-less vector) control. Vector control is effective in applications requiring high starting torque, torque limitation, etc.



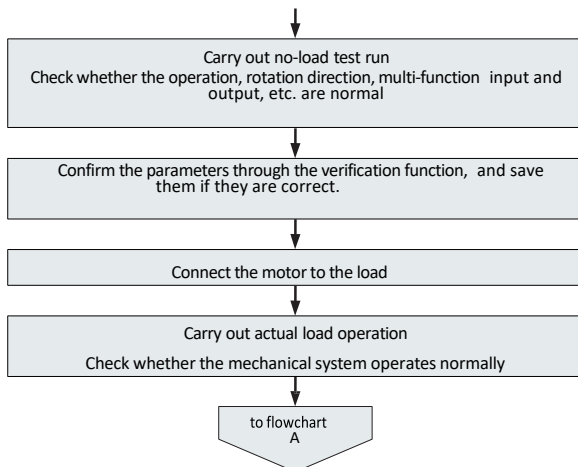

Figure 4-6 Open-loop vector control mode operation steps

### ③ Sub-flow chart A-2 (simple motor operation under V/F control mode)

When operating by V/F control, set parameters according to the following flowchart. V/F control is more effective in applications such as fans or pumps.

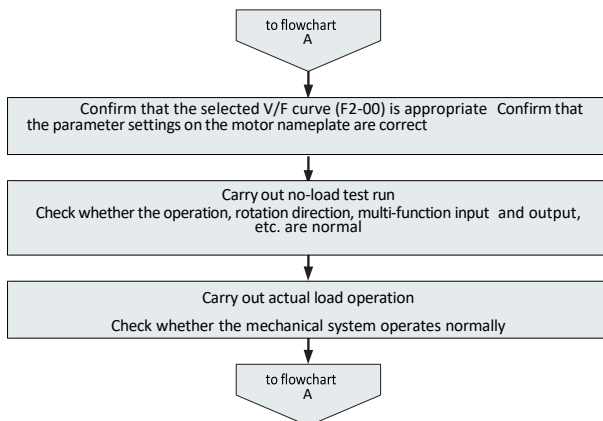

Figure 4-7 Operation steps of V/F control mode

### 4.5.3 Review of status parameters

In the stop or running state, various state parameters can be displayed respectively through the shift key " ". The function code P7-29 (running parameter) and P7-30 (stopping parameter) select the parameter display of this parameter in the running/stop state according to the binary digits. There are sixteen running/stop state parameters that can be displayed or not. Details For the description, see the parameter description of parameters P7-29 and P7-30 in Chapter 5.

## 4.6 Start-stop control of inverter

### 4.6.1 Source selection of start-stop signal

There are 3 sources for the start and stop control commands of the inverter, namely panel control, terminal control and communication control, which are selected by function parameter P0-04.

P0-04	Run command source setting		Factory default: 0	Factory default
	Predetermined area	0	Operation panel command channel (LED off)	Press RUN, STOP to start and stop
1		Terminal command channel (LED on)	The DI terminal needs to be defined as the start-stop command terminal	
2		Communication command channel (LED flashing)	Adopt MODBUS-RTU protocol	

#### 4.6.1.1 Panel start-stop control

Through the keyboard operation, make the function code P0-04=0, which is the start-stop control mode of the panel, press the "RUN" key on the keyboard, the inverter will start running (the RUN indicator light is on); when the inverter is running, press the "STOP" key on the keyboard, the inverter will stop running (RUN indicator light is off).

#### 4.6.1.2 Terminal start-stop control

The terminal start-stop control method is suitable for the occasions where the sampling toggle switch and the electromagnetic switch button are used as the start-stop of the application system, and it is also suitable for the electrical design of the controller to control the operation of the inverter with the dry contact signal.

The KD600 inverter provides a variety of terminal control modes. The terminal command mode is determined by the function code P5-11, and the input port of the start-stop control signal is determined by the function code P5-00~P5-04. For the specific setting method, please refer to the detailed explanation of function codes such as P5-11, P5-00~P5-04.

### Example 1:

It is required to use the toggle switch of the inverter as the start-stop switch of the inverter, connect the forward running switch signal to the DI2 port, and the reverse running switch signal to the DI4 port. The method of use and setting is as follows.

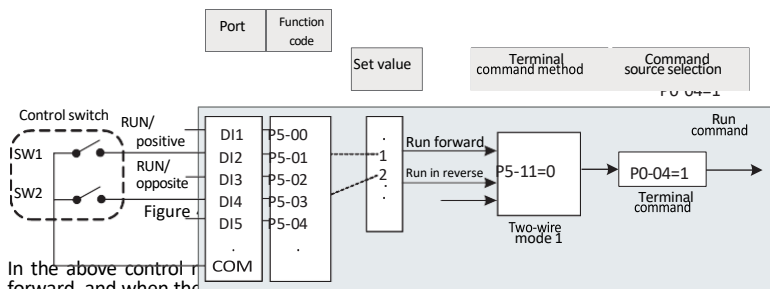

In the above control method, when the SW1 command switch is closed, the inverter runs forward, and when the SW2 command switch is off, the inverter runs reverse. When SW1 and SW2 are closed at the same time, or open at the same time, the inverter will stop running.

### Example 2:

It is required to use the key solenoid of the inverter as the start-stop switch of the inverter, connect the start button signal to the DI2 port, the stop button signal to the DI3 port, and the reverse run button signal to the DI4 port. The use and setting methods are as follows:

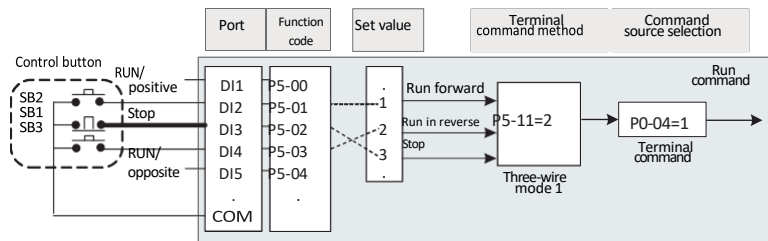

Figure 4-9 Schematic diagram of terminal control start and stop

In the above control mode, during normal startup and operation, the SB1 button must be kept closed, and the inverter will stop at the moment of opening; the commands of the SB2 and SB3 buttons will take effect at the edge of the closing action. The last button action of each button shall prevail.

#### 4.6.1.3 Communication start-stop control

The application of the host computer to control the operation of the inverter by means of RS485 communication. Select the control command source as the communication mode (P0-04=2), the start and stop of the inverter can be controlled by the communication mode. The function codes related to communication settings are as follows:

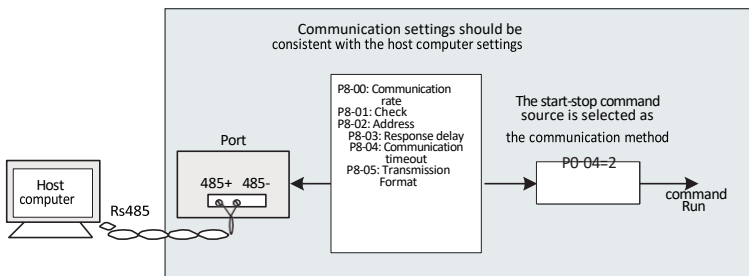

Figure 4-10 Communication control start and stop diagram

In the above figure, the function code of communication timeout time (P8-04) is set to a value other than 0, that is, the function of automatic shutdown of the inverter after the communication timeout fault is activated, which can avoid the failure of the communication line or the failure of the host computer. The frequency converter is running uncontrolled. This feature can be turned on in some applications.

The MODBUS-RTU slave protocol is built into the communication port of the inverter, and the host computer must use the MODBUS-RTU master protocol to communicate with it. For the specific communication protocol definition, please refer to Appendix A: KD600 Modbus Communication Protocol of this manual.

## 4.6.2 Start mode

There are 3 start modes of the inverter, namely direct start, speed tracking start and asynchronous motor pre-excitation start, which are selected by function parameter P1-00.

P1-00=0, direct start mode, suitable for most small inertia loads, the frequency curve of the start process is as shown in the figure below. The "DC braking" function before starting is suitable for the drive of elevators and heavy loads; the "starting frequency" is suitable for the drive of equipment that needs starting torque shock start, such as cement mixer equipment.

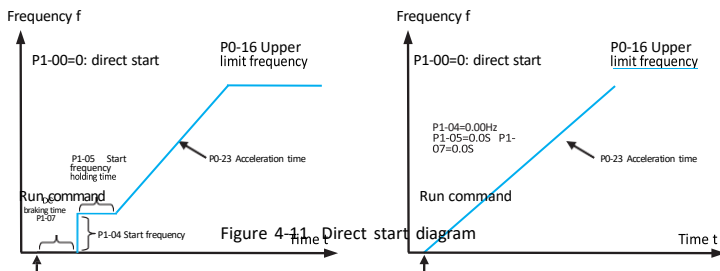

P1-00=2, the method is only applicable to the induction asynchronous motor load. Pre-exciting the motor before starting can improve the fast response characteristics of the asynchronous motor and meet the application requirements that require a relatively short acceleration time. The frequency curve of the starting process is as follows.

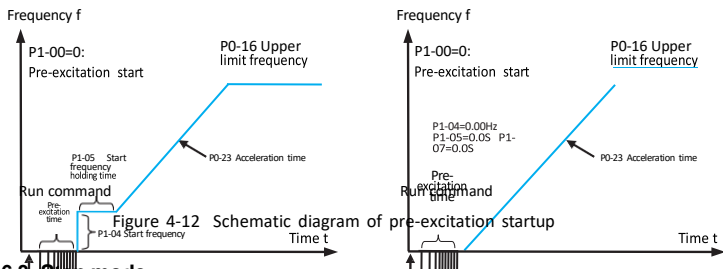

### 4.6.3 Stop mode

There are two stop modes of the inverter, namely deceleration stop and free stop, which are selected by function code P1-13.

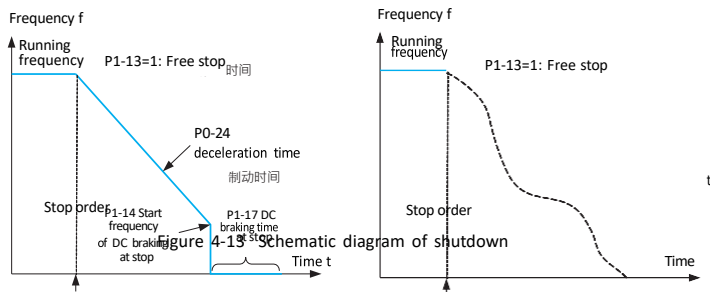

## 4.6.4 Jog operation

In many applications, the inverter needs to run at a low speed for a short time, which is convenient for testing the condition of the equipment, or other debugging actions. In this case, it is more convenient to use the jog operation.

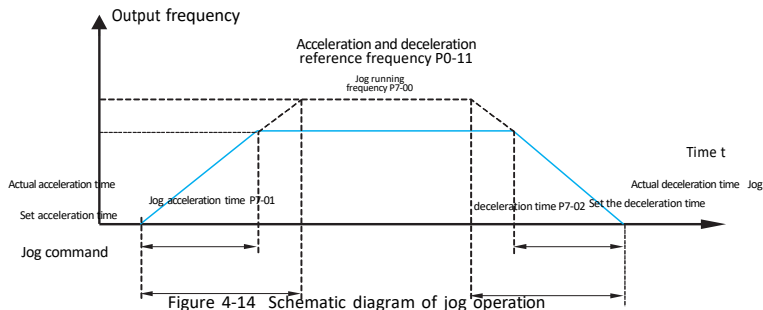

Figure 4-14 Schematic diagram of jog operation

### 4.6.4.1 Parameter setting and operation of jog operation through the operation panel

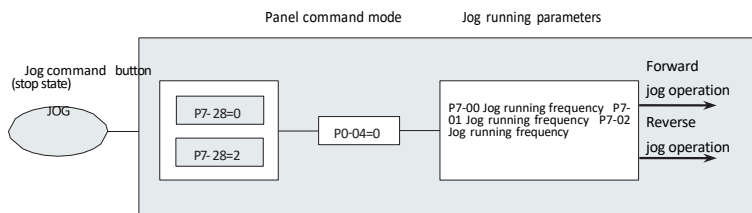

Figure 4-15 Schematic diagram of jog parameter setting

After setting the relevant function code parameters as shown in the figure above, in the inverter stop state, press the JOG key, the inverter will start to run forward at low speed, release the JOG key, the inverter will decelerate and stop.

#### 4.6.4.2 Parameter setting and operation of jog operation through DI port

On some production equipment that requires frequent jog operation, such as textile machinery, it is more convenient to control jog with keys or buttons. The relevant function code settings are as follows:

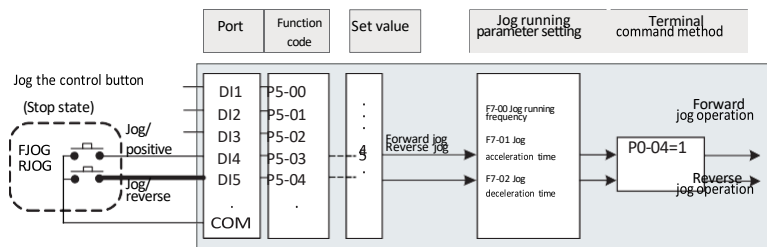

Figure 4-16 Schematic diagram of DI mode jog parameter setting

After setting the relevant function code parameters as shown in the figure above, when the inverter is stopped, press the FJOG button, the inverter will start to run forward at low speed, release the FJOG button, the inverter will decelerate and stop. Likewise, press the RJOJ button for reverse jogging.

## 4.7 Frequency converter operating frequency control

The inverter is set with 2 frequency given channels, named as main frequency source X and auxiliary frequency source Y respectively. They can work with a single channel or can be switched at any time, and can even set the calculation method for superposition and combination to meet the needs of the application site.

Different control requirements.

### 4.7.1 Main frequency given source selection

There are 9 main frequency sources of the inverter, which are digital setting (UP/DN power-off memory), digital setting (UP/DN power-off memory), AI1, AI2, PULSE input, multi-segment instruction, simple PLC, PID, communication given, etc., you can choose one of them by setting P0-06.

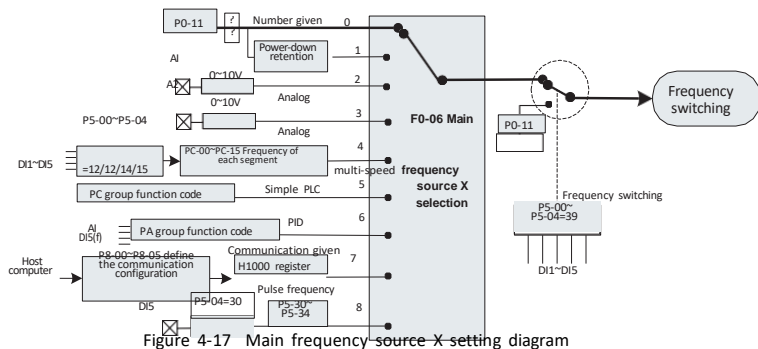

Figure 4-17 Main frequency-source X-setting diagram

It can be seen from the different frequency sources in the figure that the operating frequency of the inverter can be determined by the function code, it can also be adjusted manually in real time, it can also be given by the analog quantity, and it can also be given by the multi-speed terminal command. It can be closed-loop regulated by the built-in PID regulator through the external feedback signal; it can also be controlled by the host computer communication.

The above figure shows the relevant function code numbers of each frequency source given setting, and you can refer to the detailed description of the corresponding function code when setting.

#### 4.7.2 Using method with auxiliary frequency given

The auxiliary frequency source Y source is the same as the main frequency source, which is selected by the setting of P0-07.

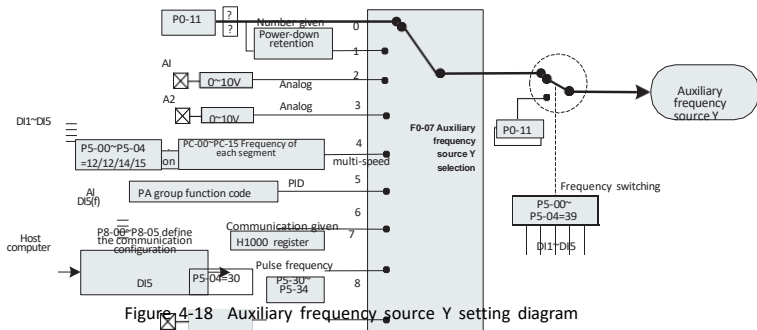

Figure 4-18 Auxiliary frequency source Y setting diagram

In actual use, the relationship between the target frequency and the main and auxiliary frequency sources is set through P0-10.

### 4.7.3 Frequency closed loop control for process control

KD600 has a built-in PID regulator, and with the selection of frequency given channel, users can easily realize automatic adjustment of process control, such as constant temperature, constant pressure, tension and other control applications.

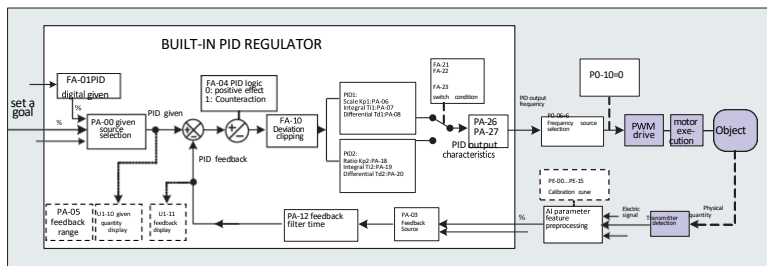

Figure 4-19 Schematic diagram of frequency closed-loop control

When using PID frequency closed-loop control, it is necessary to select the frequency source P0-06=6: that is, select the PID output frequency. PID related parameters are in the PA group function parameters, and the related PID function code relationship is shown in the figure above.

KD600 inverter has built-in 2 equivalent PID calculation units, whose characteristic parameters can be set separately, which is suitable for the application of different PID adjustment characteristics according to the working conditions, respectively emphasizing the adjustment speed and accuracy of PID. External DI terminal signal control.

#### 4.7.4 Wobble frequency working mode setting

In textile and chemical fiber processing equipment, using the swing frequency function can improve the evenness and density of the spindle winding, as shown in the figure below. It can be realized by setting the function codes from Pb-00 to Pb-04. For the specific method, please refer to the detailed description of the corresponding function code.

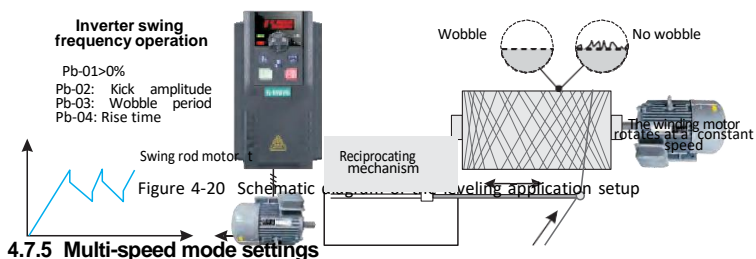

#### 4.7.5 Multi-speed mode settings

For applications that do not need to continuously adjust the operating frequency of the inverter, but only need to use several frequency values, when multi-speed control can be used, the KD600 can set up to 16 operating frequencies, which can be selected by the combination of 4 DI input signals. Set the function code corresponding to the DI port to the function value of 12 to 15, that is to say, it is designed as the multi-segment frequency command input port, and the required multi-segment frequency is set by the multi-segment frequency table of the PC group. Specify as multi-segment frequency given mode, as shown in the following figure:

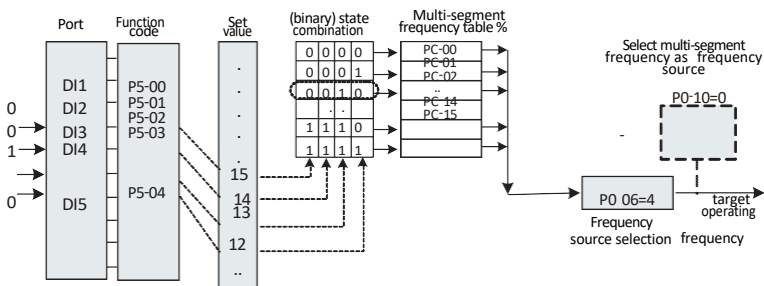

Figure 4-21 Schematic diagram of multi-speed control

In the figure above, DI2, DI3, DI4, and DI5 are selected as the signal input terminals for multi-segment frequency designation, and 4-bit binary numbers are formed from them in turn, and the multi-segment frequency is selected by combining the values according to the state. When (DI5, DI4, DI3, DI2) = (0, 0, 1, 0), the number of state combinations formed is 2, and the frequency set by the PC-02 function code will be selected as the target operating frequency.

KD600 can set up to 4 DI ports as multi-segment frequency command input terminals, and also allow less than 4 DI ports to perform multi-segment frequency setting. For the missing setting bits, it is always calculated as state 0.

#### 4.7.6 Motor running direction setting

After the inverter restores the factory parameters, press the "RUN" key, the inverter drives the motor's direction, which is called the forward direction. If the rotation direction at this time is opposite to the direction required by the equipment, please set PO-13=1 or power off. After that (pay attention to the discharge of the main capacitor charge of the inverter), replace any two wirings in the UVW output line of the inverter to eliminate the problem of the rotation direction.

In some drive systems, only the system is allowed to run in the forward direction and not in the reverse direction, you need to set PO-13 = 2. If there is a reverse command at this time, the inverter will decelerate to 0 and enter the stop state, and at the same time FWD/REV keeps flashing on the operation panel. The logic shown in the figure below.

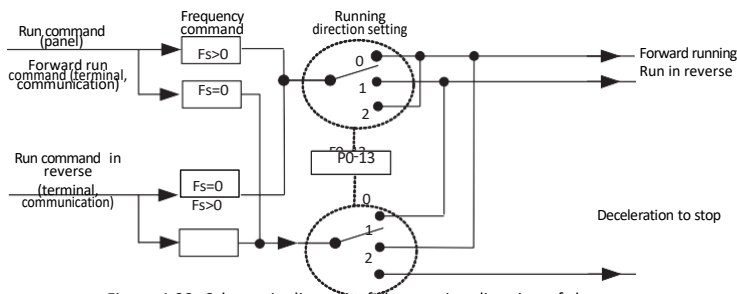

Figure 4-22 Schematic diagram of the running direction of the motor

For applications that do not allow motor reversal, please do not use the method of modifying the function code to change the direction, because the above two function codes will be reset after restoring the factory defaults. At this time, the function of No. 50 of the digital input terminal DI can be used to prohibit reverse rotation.

#### 4.7.7 Fixed-length control mode settings

KD600 has a fixed-length control function. The length pulse is collected through the DI (DI function selection is 30) terminal. The number of pulses sampled by the terminal is divided by the number of pulses per meter Pb-07, and the actual length Pb-06 can be calculated. When the actual length is greater than the set length Pb-05, the multi-function digital switch output "length reached" ON signal.

During the fixed-length control process, the length reset operation can be performed through the multi-function DI terminal (the DI function selection is 31), and the specific settings are shown in the following figure.

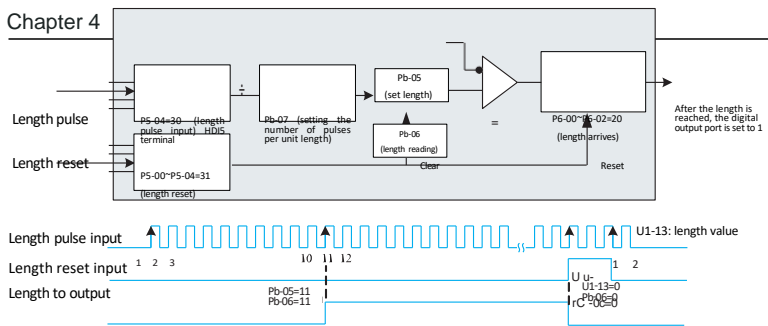

Figure 4-23 Fixed-length control mode function code setting

**Notice:**

- Fixed-length control mode, the direction cannot be recognized, and the length can only be calculated according to the number of pulses.
- The HDI terminal can be used as the "length count input" terminal.
- Back the digital output signal whose length has reached to the stop input terminal of the inverter, which can be made into an automatic stop system.

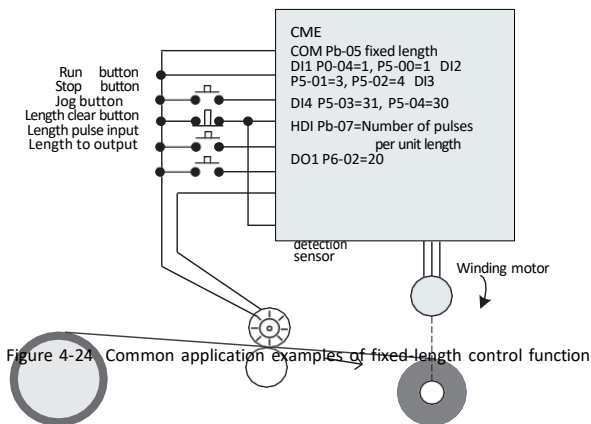

Figure 4-24 Common application examples of fixed-length control function

### 4.7.8 How to use the inverter count function

The count value needs to be collected through the DI (DI function selection is 28) terminal. When the count value reaches the set count value Pb-08, the multi-function digital switch output "set count value reached" ON signal, and then the counter stops counting.

When the count value reaches the designated count value Pb-09, the multi-function digital switch value outputs the "designated count value reached" ON signal, and the counter continues to count at this time, and the counter stops until the "set count value".

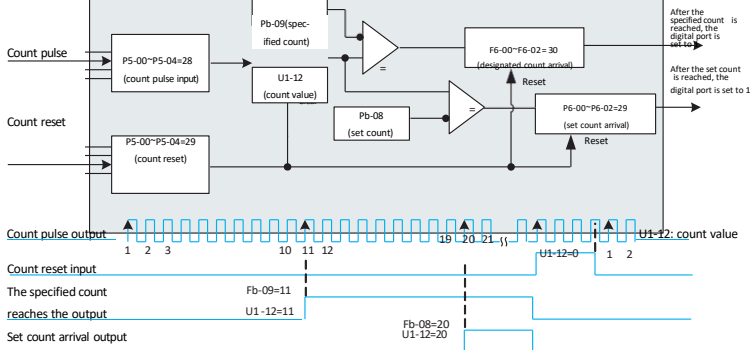

Figure 4-25 Counting mode function code setting



Specified count value Pb-09 should not be greater than the set count value Pb-08.

When the pulse frequency is high, the DI5 port must be used.

Digital ports of "set count arrival" and "specified count arrival" cannot be reused.

When the RUN/STOP state of the inverter, the counter will continue to count, and will not stop counting until the "set count value".

Count value can be kept when power off.

➢ Feedback the count reaching switch output signal to the inverter stop input terminal, which can be made into an automatic stop system.

## 4.8 Motor characteristic parameter setting and automatic tuning

### 4.8.1 Motor parameters to be set

When the inverter runs in the "vector control" (P0-03=1) mode, it has a strong dependence on the accurate motor parameters, which is one of the important differences from the "VF control" (P0-03=2) mode. In order for the inverter to have good drive performance and operating efficiency, the inverter must obtain the accurate parameters of the controlled motor.

The required motor parameters are (default motor 1 function code):

Motor 1 parameters	Parameter Description	Illustrate
P4-01~P4-06	Motor rated power/voltage/current/frequency/speed	Model parameters, manually input
P4-07~P4-11	Equivalent stator resistance, inductive reactance, rotor inductance, etc. inside the motor	Tuning parameters

### 4.8.2 Automatic tuning and identification of motor parameters

The methods for the inverter to obtain the internal electrical parameters of the controlled motor include: dynamic identification, static identification, and manual input of motor parameters.

Identification method	Applicable	Identification effect
No-load dynamic identification	Suitable for synchronous motors and asynchronous motors. Occasions where the motor and the application system are easily separated	Optimal
On-load dynamic identification	Suitable for synchronous motors and asynchronous motors. Occasions where it is inconvenient to separate the motor from the application system	Can
Static identification	It is only suitable for asynchronous motors, where it is difficult to separate the motor from the load and dynamic identification is not allowed.	Poor
Enter parameters manually	Applies to asynchronous motors only. In the case where it is difficult to separate the motor from the application system, copy the parameters of the motor of the same type that the inverter has successfully identified before and input it into the corresponding function codes of P4-01~P4-11	Can

The steps of automatic tuning of motor parameters are as follows:

The following takes the parameter identification method of default motor 1 as an example to explain, and the identification method of motor 2 is the same.

### Step 1:

If the motor can be completely disconnected from the load, in the case of power failure, mechanically disconnect the motor from the load part, so that the motor can rotate freely without load.

### Step 2:

After power-on, first select the inverter command source (P0-04) as the operation panel command channel.

### Step 3:

Input the nameplate parameters of the motor accurately (such as P4-01~P4-06), please input the following parameters according to the actual parameters of the motor (selected according to the current motor):

Motor selection	Parameters
Motor 1	P4-01: Motor rated power      P4-02: Motor rated voltage P4-04: Motor rated current      P4-05: Motor rated frequency P4-06: Motor rated speed
Motor 2	A1-01 to A1-06: Same as above definition

### Step 4:

If it is an asynchronous motor, please select 2 (dynamic full tuning) for P4-00 (tuning selection, for motor 2, it corresponds to A1-00 function code), and press ENTER to confirm. At this time, the keyboard displays:



Then press the RUN key on the keyboard panel, the inverter will drive the motor to accelerate and decelerate, run forward and reverse, the running indicator lights up, and the identification running lasts about 2 minutes. When the above display information disappears, it returns to the normal parameter display state, indicating that the tuning is completed. After this complete tuning, the frequency converter automatically calculates the following parameters for the motor:

Motor selection	Parameters	
Motor 1	P4-07: Motor 1 no-load current P4-09: Motor 1 rotor resistance P4-11: Motor 1 leakage inductance	P4-08: Motor 1 stator resistance P4-10: Motor 1 mutual inductance P4-11: Motor 1 leakage inductance
Motor 2	A1-07 ~ A1-11: Same as above	

If the motor cannot be completely disconnected from the load, select 1 (static tuning) for P4-00 (motor 2 is P1-00), and then press the RUN key on the keyboard panel to start the motor parameter identification operation.

### 4.8.3 Setting and switching of multiple sets of motor parameters

It can be specified by the function code A0-00, or the digital input terminal function 41 can select the current valid motor parameter group. However, when the digital input terminal function 41 is valid, it is the priority, and the setting of A0-00 is invalid at this time.

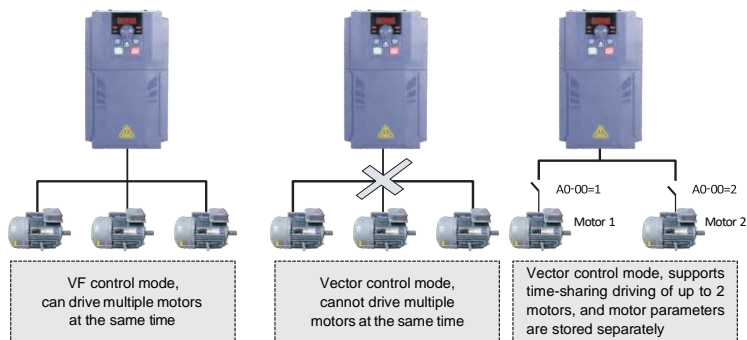

Figure 4-26 Switching of multiple sets of motors

### 4.9 How to use the DI port of the inverter

The control board comes with 5 DI ports, numbered DI1~DI5. The internal hardware of the DI port is equipped with a 24Vdc power supply for detection. Users only need to short-circuit the DI port and the COM port to input the DI signal to the inverter.

In the factory default state, P5-13=00000, when the DI port is short-circuited, it is a valid (logic 1) signal; when the DI port is floating, the DI is an invalid (logic 0) signal; the user can also change the DI port's signal Valid mode, that is, when the DI port is short-circuited, it is an invalid (logic 0) signal; when the DI port is floating, the DI is a valid (logic 1) signal. At this time, it is necessary to modify the corresponding bit of P5-13 to 1, the two function codes correspond to the valid mode settings of DI1~DI5 respectively.

The inverter also sets a software filter time (P5-10) for the input signal of the DI port, which can improve the anti-interference level. For the DI1~DI3 input ports, the port signal delay function is also provided, which is convenient for some applications that require delay processing:

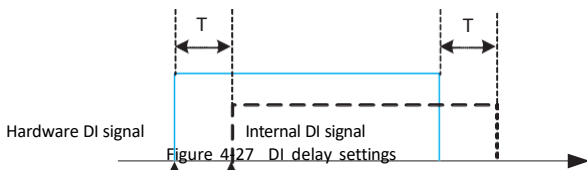

The functions of the above five DI ports can be defined in the function codes of P5-00~P5-04, and each DI can be selected from 53 functions according to requirements. For details, please refer to the detailed description of P5-00~P5-04 function codes.

In the design of hardware features, only HDI can accept high-frequency pulse signals. For applications that require high-speed pulse counting, please arrange it on the HDI port.

#### 4.10 How to use the DO port of the inverter

The control board comes with 2 digital outputs, which are the control board relays RELAY1 and Y1, of which Y1 is a transistor output, which can drive a 24Vdc low-voltage signal circuit; the relay output can drive a 50Vac control circuit.

By setting the value of function parameters P6-00 to P6-02, various digital output functions can be defined, which can be used to indicate various working states and various alarms of the inverter. There are about 45 function settings in total, so that users can achieve specific Automatic control requirements. For specific setting values, please refer to the detailed description of the function code parameters in Group P6-

### 4.11 AI input signal characteristics and preprocessing

The inverter supports a total of 2 channels of AI resources.

Port	Input signal characteristics
AI1-GND	Accept 0~10Vdc signal
AI2-GND	The jumper cap switch "AI2 I-U" is at the "U" mark and can accept 0~10Vdc signals; When the jumper cap switch "AI2 I-U" is at the "I" mark, it can accept 0~20mA current signal.

Users can preset up to 3 conversion curves for input values, and different AI channels can use the same conversion curve

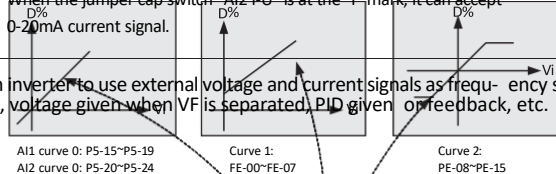

AI can be used as an inverter to use external voltage and current signals as frequency source given, torque given, voltage given when VF is separated, PID given on feedback, etc.

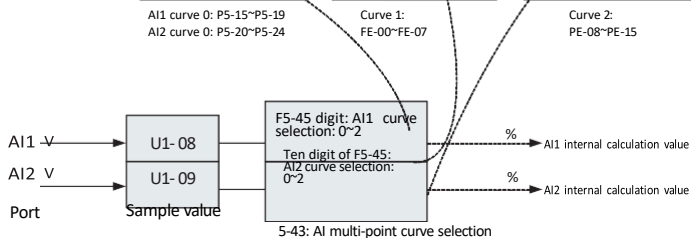

Figure 4-28 AI signal corresponds to actual given

The sampled value of the AI port can be read in the function codes U1-08 and U1-09. The converted calculated value is used for internal subsequent calculations, and the user cannot read it directly.

## 4.12 How to use the AO port of the inverter

The inverter supports a total of 2 AO outputs.

Port	Input signal characteristics
AO1-GND	The jumper cap switch "AO1 I-U" is at the "U" mark position, which can output 0~10Vdc signal
	The jumper cap switch "AO1 I-U" is at the "I" mark position, which can output 0~20mA current signal
AO2-GND	The jumper cap switch "AO2 I-U" is at the "U" mark position, which can output 0~10Vdc signal
	The jumper cap switch "AO2 I-U" is at the "I" mark position, which can output 0~20mA current signal

AO1 and AO2 can be used to indicate internal running parameters in analog mode, and the indicated parameter attributes can be selected through function codes P6-09 and P6-10.

The specified running parameters can also be corrected before output. The correction characteristic curve is shown as the slash in the figure below. For the description of function codes P6-13~P6-16, please refer to the relevant description in Chapter 5.

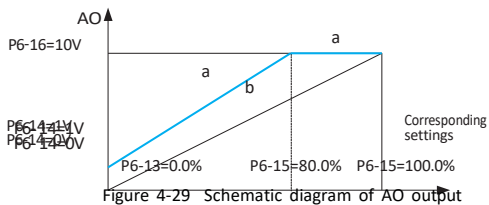

Figure 4-29 Schematic diagram of AO output

### 4.13 How to use inverter serial communication

See the P8 group function for the hardware communication parameter configuration of the communication port. Setting the communication rate and data format to be consistent with the host computer is the premise for normal communication.

The serial port of KD600 has a built-in MODBUS-RTU slave communication protocol. The host computer can query or modify the inverter function code, various running status parameters, and send running commands and operating frequencies to the inverter through the serial port.

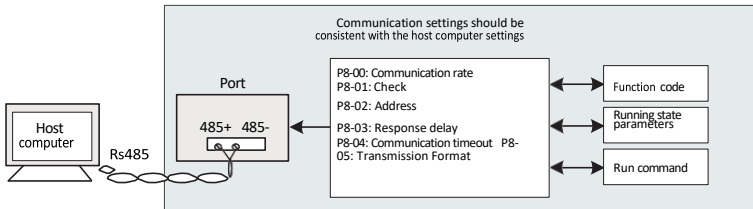

Figure 4-30 Communication setting diagram

The internal information of function codes, various operating status parameters, various operating instructions and other information in KD600 is organized in the way of "register parameter address".

For more details, please refer to Appendix A: KD600 Modbus Communication Protocol.

### 4.14 Password setting

The inverter provides the user password protection function. When P7-49 is set to non-zero, it is the user password. After returning to the status parameter interface, the password protection will take effect. At this time, press the PRG key, it will display " ", only the status parameters are displayed, you must press the key on

the " " interface, and the panel displays "00000", after entering the user password correctly, you can enter the normal menu to check and set the function code, otherwise the panel will display " " and the function code cannot be entered.

If you want to cancel the password protection function, you can only enter through the password according to the above steps, and set P7-49 to 0.



## **Function & Parameter Table**

5.1 Functional group.....	78
---------------------------	----

### The function code symbols are explained as follows:

Icons	Content
☆	Indicates that the inverter parameters can be modified during stop and running (0)
★	Indicates that the inverter is in a running state and cannot be modified (1)
○	Indicates that this parameter is a manufacturer's parameter and cannot be changed by the user (3)
●	Indicates the actual detection value of the inverter or the manufacturer's fixed value, which cannot be changed (2)

The communication address in the function parameter table is written in hexadecimal.

**Enhanced function codes:** Group A0~Group A3, Group B0~Group B6, opened by function parameter P7-75.

Function code	Name	Description (setting range)	Factory Default	Change
<b>Group P0: Basic function group</b>				
P0-00	Product number	Product model: 5 digits display, 2 decimal places	60#.##	●
P0-01	Inverter GP type display	0: G type 1: P type	0	★
P0-02	Rated current	0.1A~3000.0A	Model is determined	●
P0-03	Motor control method	Ones place: motor control mode selection 1: Open loop vector control (speed sensorless vector) 2: VF Control 3: Closed loop vector (with speed sensor vector) Tens place: motor type selection 0: Asynchronous motor 1: Synchronous motor	2	★
P0-04	Run command source	0: Operation panel running command channel (LED off) 1: Terminal command channel (LED on) 2: Communication command channel (LED flashes)	0	★

Function code	Name	Description (setting range)	Factory Default	Change
P0-05	Up/Down to modify the frequency command reference during runtime	0: Running frequency 1: Setting frequency	1	★
P0-06	Main frequency source X selection	0: Up/Down modification frequency, no memory after shutdown 1: Up/Down modification frequency power-off memory 2: AI1 3: AI2 4: Multi-speed 5: Simple PLC 6: PID 7: Communication given 8: PULSE pulse setting 9: Up/Down modifies the frequency, and the memory is stopped when the power is turned off.	1	★
P0-07	Auxiliary frequency source Y selection	0: Up/Down modification frequency, no memory after shutdown 1: Up/Down modification frequency power-off memory 2: AI1 3: AI2 4: Multi-speed 5: Simple PLC 6: PID 7: Communication given 8: PULSE pulse setting 9: Up/Down modifies the frequency, and the memory is stopped when the power is turned off.	0	★
P0-08	Auxiliary frequency source Y range selection	0: relative to the maximum frequency 1: Relative to frequency source X 2: The range is the same as 0 but the main and auxiliary have no negative frequency output	0	☆

## Chapter 5 Function & Parameter Table

Function code	Name	Description (setting range)	Factory Default	Change
P0-09	Auxiliary frequency source Y range	0% to 100%	100%	☆
P0-10	Frequency source selection	<p>Ones place: frequency source selection</p> <p>0: Main frequency source X</p> <p>1: Main and auxiliary operation results (the operation relationship is determined by ten digits)</p> <p>2: Switch between main frequency source X and auxiliary frequency source Y</p> <p>3: Switch between the main frequency source X and the main and auxiliary operation results</p> <p>4: Switch between auxiliary frequency source Y and main and auxiliary operation results</p> <p>Tens place: main and auxiliary operation relationship of frequency source</p> <p>0: main + auxiliary</p> <p>1: Primary-Secondary</p> <p>2: the maximum value of the two</p> <p>3: the minimum value of the two</p>	00	☆
P0-11	Preset frequency	0.00Hz~Maximum frequency P0-14	50.00Hz	☆
P0-13	Motor running direction selection	<p>0: Consistent with the current motor direction</p> <p>1: Opposite to the current motor direction</p> <p>2: Inversion is prohibited</p>	0	☆
P0-14	Maximum output frequency	<p>When P0-20=1, the adjustable range is 50.0Hz~1200.0Hz;</p> <p>When P0-20=2, the adjustable range is 50.00Hz~600.00Hz;</p>	50.00Hz	★
P0-15	Upper limit frequency source	<p>0: Digital given (P0-16)</p> <p>1: AI1</p> <p>2: AI2</p> <p>3: Communication given</p> <p>4: PULSE setting</p>	0	★

Function code	Name	Description (setting range)	Factory Default	Change
P0-16	Upper limit frequency	Lower limit frequency P0-18~maximum frequency P0-14	50.00Hz	☆
P0-17	Upper limit frequency offset	0.00~Maximum frequency P0-14	0.00Hz	☆
P0-18	Lower frequency	0.00Hz~upper limit frequency P0-16	0.00Hz	☆
P0-19	Command source binding selection	Units digit: selection of frequency source bound by operation panel command 0: no binding 1: Digital setting frequency 2: AI1 3: AI2 4: Multi-speed 5: Simple PLC 6: PID 7: Communication given 8: PULSE pulse setting (DI5) Tens place: Terminal command binding frequency source selection Hundreds place: Communication command binding frequency source selection Thousands: reserved	000	☆
P0-20	Frequency Decimal Selection	1: 1 decimal point 2: 2 decimal places	2	★
P0-21	Acceleration and deceleration time unit	0: 1 second 1: 0.1 seconds 2: 0.01 seconds	1	★
P0-22	Acceleration and deceleration time reference frequency	0: Maximum frequency (P0-14) 1: Preset frequency (P0-11) 2: Motor rated frequency (P4-05 or A1- 05)	0	★
P0-23	Acceleration time 1	0s~30000s(P0-21=0) 0.0s~3000.0s(P0-21=1) 0.00s~300.00s(P0-21=2)	10.0s	☆
P0-24	Deceleration time 1	0s~30000s(P0-21=0) 0.0s~3000.0s(P0-21=1) 0.00s~300.00s(P0-21=2)	10.0s	☆

## Chapter 5 Function & Parameter Table

Function code	Name	Description (setting range)	Factory Default	Change
P0-25	Overmodulation voltage boost value	0%~10%	3%	★
P0-26	Carrier frequency	0.5kHz~16.0kHz	Model is determined	☆
P0-27	The carrier frequency is adjusted with temperature	0: Invalid; 1: Valid;	1	☆
P0-28	Parameter initialization	0: No operation 1: Restore factory parameters, excluding motor parameters, record information and frequency decimal point P0-20 2: Clear record information 3: Backup current user parameters 4: Restore user backup parameters	0	★
P0-29	LCD upload and download parameter selection	0: No function 1: Download parameters to LCD 2: Only upload P4 group parameters 3: Upload parameters other than group P4 4: Upload all parameters	0	☆
<b>Group P1: Start-stop control</b>				
P1-00	Start method	0: direct start 1: Speed Tracking 2: Asynchronous motor pre-excitation start	0	☆
P1-01	Speed tracking method	0: start from stop frequency 1: Start with target frequency 2: start from maximum frequency	0	★
P1-02	Maximum speed tracking current	30%~150%	100%	★
P1-03	Speed tracking speed	1~100	20	☆
P1-04	Start frequency	0.00Hz~10.00Hz	0.00Hz	☆
P1-05	Start frequency hold time	0.0s~100.0s	0.0s	★
P1-06	Start DC braking current	0%~100%	0%	★

Function code	Name	Description (setting range)	Factory Default	Change
P1-07	Start DC braking time	0.0s~100.0s	0.0s	★
P1-08	Selection of acceleration and deceleration frequency curve mode	0: Straight line 1: S curve A 2: S curve B (P1-09~P1-12 unit is 0.01s)	0	★
P1-09	S-curve acceleration start time	0.0%~100.0%	20.0%	★
P1-10	S-curve acceleration end time	0.0%~100.0%	20.0%	★
P1-11	S-curve deceleration start time	0.0%~100.0%	20.0%	★
P1-12	S-curve deceleration end time	0.0%~100.0%	20.0%	★
P1-13	Stop mode	0: Decelerate to stop 1: Free stop	0	☆
P1-14	DC braking start frequency at stop	0.00Hz~P0-14	0.00Hz	☆
P1-15	DC braking waiting time at stop	0.0s~100.0s	0.0s	☆
P1-16	Stop braking DC current	0%~100%	0%	☆
P1-17	DC braking time at stop	0.0s~36.0s	0.0s	☆
P1-21	Demagnetization time	0.01s~3.00s	0.50s	★
P1-23	Instantaneous stop and non-stop mode selection	0: invalid 1: Automatically adjust the deceleration rate 2: Decelerate to stop	0	★
P1-24	The deceleration time of the momentary stop and non-stop deceleration stop	0.0s~100.0s	10.0s	★
P1-25	Instantaneous power failure and non-stop effective voltage	60%~85%	80%	★
P1-26	Instantaneous power failure and non-stop recovery of voltage	85%~100%	90%	★
P1-27	Instantaneous power failure and non-stop recovery voltage judgment	0.0s~300.0s	0.3s	★
P1-28	Instantaneous stop and non-stop automatic gain adjustment	0~100	40	☆

## Chapter 5 Function & Parameter Table

Function code	Name	Description (setting range)	Factory Default	Change
P1-29	Instantaneous stop and non- stop automatic adjustment of integral	1~100	20	☆
<b>Group P2: V/F control parameters</b>				
P2-00	V/F curve setting	0: Straight line VF curve 1: Multi-point VF curve 2: Square VF curve 3: 1.7th power curve 4: 1.5 power curve 5: 1.3 power curve 6: VF full separation mode 7: V/F half separation mode	0	★
P2-01	Torque boost	0.0%~30.0%	0.0%	☆
P2-02	Torque boost cut-off frequency	0.00Hz~Maximum frequency	25.00Hz	★
P2-03	V/F frequency point P1	0.00Hz~P2-05	1.30Hz	★
P2-04	V/F voltage point V1	0.0%~100.0%	5.2%	★
P2-05	V/F frequency point P2	P2-03~P2-07	2.50Hz	★
P2-06	V/F voltage point V2	0.0%~100.0%	8.8%	★
P2-07	V/F frequency point P3	Motor rated frequency	15.00Hz	★
P2-08	V/F voltage point V3	0.0%~100.0%	35.0%	★
P2-09	Slip Compensation Coefficient	0.0%~200.0%	50.0%	☆
P2-10	Flux Brake Gain	0~200	100	☆
P2-11	Oscillation suppression gain	0~100	Model is determined	☆
P2-13	VF slip compensation time constant	0.02s~1.00s	0.30s	☆
P2-15	Output voltage source selection when VF is separated	0: Digital setting (P2-14) 1: AI1 2: AI2 3: Multi-segment instruction 4: Simple PLC 5: PID	0	☆

Function code	Name	Description (setting range)	Factory Default	Change
P2-15	Output voltage source selection when VF is separated	6: Communication given 7: PULSE pulse setting (DI5) 100.0% corresponds to the rated voltage of the motor	0	☆
P2-16	V/F separation output voltage digital setting	0V~Motor rated voltage	0V	☆
P2-17	V/F separation output voltage acceleration time	0.0~3000.0s	1.0s	☆
P2-18	V/F separation output voltage deceleration time	0.0~3000.0s	1.0s	☆
P2-19	V/F separation and stop mode selection	0: Frequency and output voltage deceleration time are independent 1: After the voltage is reduced to 0, the frequency is reduced again	0	☆
<b>Group P3: Vector control parameters</b>				
P3-00	Switching frequency P1	0.00~P3-02	5.00 Hz	☆
P3-02	Switching frequency P2	P3-00~P0-14	10.00 Hz	☆
P3-04	Low frequency speed proportional gain	0.1~10.0	4.0	☆
P3-05	Low frequency speed integration time	0.01s~10.00s	0.50s	☆
P3-06	High frequency speed proportional gain	0.1~10.0	2.0	☆
P3-07	High frequency speed integration time	0.01~10.00s	1.00s	☆
P3-08	Speed loop integral attribute selection	0: Points take effect 1: Integral separation	0	★
P3-11	Torque current regulator Kp	0~30000	2200	☆
P3-12	Torque current regulator Ki	0~30000	1500	☆
P3-13	Excitation current regulator Kp	0~30000	2200	☆
P3-14	Excitation current regulator Ki	0~30000	1500	☆
P3-15	Flux Brake Gain	0~200	0	☆

## Chapter 5 Function & Parameter Table

Function code	Name	Description (setting range)	Factory Default	Change
P3-16	Field weakening torque correction factor	50%~200%	100%	☆
P3-17	Slip compensation gain	50%~200%	100%	☆
P3-18	Speed loop feedback filter time constant	0.000~1.000s	0.015s	☆
P3-19	Speed loop output filter time constant	0.000~1.000s	0.000s	☆
P3-20	Electric torque upper limit source	0: P3-21 1: AI1 2: AI2 3: Communication given 4: PLUSE given (The analog range corresponds to P3-21)	0	☆
P3-21	Electric torque upper limit	0.0%~200.0%	150.0%	☆
P3-22	Braking torque upper limit source	0: P3-23 1: AI1 2: AI2 3: Communication given 4: PLUSE given (The analog range corresponds to P3-23)	0	☆
P3-23	Braking torque upper limit	0.0~200.0%	150.0%	☆
P3-24	Low-speed magnetizing current of synchronous motor	0.0%~50.0%	25.0%	★
P3-25	Magnetizing cut-off frequency of synchronous motor	0%~100%	10%	★
P3-26	Pre-excitation time	0s~5s	0.1s	★
P3-27	Synchronous motor initial position identification enable selection	0: Disable 1: Identification method one 2: Identification method 2	1	★
P3-28	Initial position identification voltage given percentage	30%~130%	80%	★
<b>Group P4: First motor parameter</b>				
P4-00	Motor parameter tuning	0: no function 1: Static tuning 2: Rotary tuning	0	★

Function code	Name	Description (setting range)	Factory Default	Change
P4-01	Motor 1 rated power	0.1kw~1000.0kw	Model is determined	★
P4-02	Motor 1 rated voltage	1V~1500V	380V	★
P4-03	Motor 1 Number of motor poles	2 to 64	Model is determined	○
P4-04	Motor 1 rated current	0.01A~600.00A(Motor rated power<=30.0KW) 0.1A~6000.0A(Motor rated power>30.0KW)	P4-01 OK	★
P4-05	Motor 1 rated frequency	0.01Hz~P0-14	50.00 Hz	★
P4-06	Motor 1 rated speed	0rpm~60000rpm	P4-01 OK	★
P4-07	Motor 1 no-load current	0.01A~P4-04 (Motor rated power<=30.0KW) 0.1A~P4-04 (Motor rated power>30.0KW)	Model is determined	★
P4-08	Motor 1 stator resistance	0.001Ω~65.535Ω	Model is determined	★
P4-09	Motor 1 rotor resistance	0.001Ω~65.535Ω	Model is determined	★
P4-10	Motor 1 mutual inductance	0.1Mh~6553.5Mh	Model is determined	★
P4-11	Motor 1 leakage inductance	0.01Mh~655.35Mh	Model is determined	★
P4-12	Acceleration at Dynamic Full Tuning	1.0s~6000.0s	10.0s	☆
P4-13	Deceleration at dynamic full tuning	1.0s~6000.0s	10.0s	☆
P4-17	Synchronous motor stator resistance	0.001Ω~65.535Ω	Model is determined	★
P4-18	Synchronous motor D-axis inductance	0.01Mh~655.35Mh	Model is determined	★
P4-19	Synchronous motor Q-axis inductance	0.01Mh~655.35Mh	Model is determined	★
P4-20	Synchronous motor back EMF	1V~65535V	Model is determined	★
P4-21	No-load current of synchronous motor	0.0%~50.0%	10.0%	★

## Chapter 5 Function & Parameter Table

Function code	Name	Description (setting range)	Factory Default	Change
<b>Group P5: Input terminal</b>				
P5-00	DI1 terminal function	0: No function 1: Forward rotation (FWD) 2: Reverse operation (REV) 3: Three-wire running control 4: Forward jog (FJOG) 5: Reverse Jog (RJOG) 6: Terminal UP 7: Terminal DOWN	1	★
P5-01	DI2 terminal function	8: Free parking 9: Fault reset (RESET) 10: run pause 11: External fault normally open input 12: Multi-segment command terminal 1 13: Multi-segment command terminal 2 14: Multi-segment command terminal 3	2	★
P5-02	DI3 terminal function	15: Multi-segment command terminal 4 16: Acceleration and deceleration selection terminal 1 17: Acceleration and deceleration selection terminal 2 18: Frequency source switching 19: UP/DOWN setting clear (terminal, keyboard) 20: Running command switching terminal 21: Acceleration and deceleration prohibition 22: PID invalid (pause)	9	★
P5-03	DI4 terminal function	23: PLC status reset 24: Swing frequency pause 25: Timing trigger input 26: Immediate DC braking 27: External fault normally closed input 28: Counter input 29: Counter reset	12	★
P5-04	DI5 terminal function	30: Length count input 31: Length count reset 32: Torque control prohibited 33: PULSE (pulse) frequency input 34: Frequency modification prohibited 35: PID action direction is reversed 36: External parking terminal 1	13	★
P5-05	DI6 terminal function		13	★
P5-06	DI7 terminal function		13	★

Function code	Name	Description (setting range)	Factory Default	Change
P5-07	DI8 terminal function	37: Control command switching terminal 2 38: PID integral pause terminal 39: Frequency source X and preset frequency switching terminal 40: Frequency source Y and preset frequency switching terminal 41: Switch between motor 1 and motor 2 42: reserved 43: PID parameter switching terminal 44: Speed control/torque control switching 45: Emergency stop	0	★
P5-08	DI9 terminal function	46: External parking terminal 2 47: Deceleration DC braking 48: This running time is cleared 49: Two-wire/three-wire switch 50: Inversion prohibited 51: User-defined fault 1 52: User-defined fault 2 53: Sleep Input	0	★
P5-09	DI10 terminal function	(Optional accessories: IO2 card supports DI6, DI7 expansion; Io1 card supports DI6, DI7, DI8, DI9, DI10 expansion.)	0	★
P5-10	DI terminal filter time	0.000~1.000s	0.010s	☆
P5-11	Terminal command method	0: Two-wire type 1 1: Two-wire type 2 2: Three-wire type 1 3: Three-wire type 2	0	★
P5-12	Terminal UP/DOWN change rate	0.01Hz/s~100.00Hz/s	1.00Hz/s	☆
P5-13	Terminal valid logic 1	0: High level 1: low level Ones place: DI1; Tens place: DI2; Hundreds: DI3; Thousands: DI4; Ten thousand: DI5	00000	★

## Chapter 5 Function & Parameter Table

Function code	Name	Description (setting range)	Factory Default	Change
P5-15	AI1 minimum input value	0.00~P5-17	0.00V	☆
P5-16	AI1 minimum input corresponding setting	-100.0%~100.0%	0.0%	☆
P5-17	AI1 maximum input value	P5-15~10.00V	10.00V	☆
P5-18	AI1 maximum input corresponding setting	-100.0%~100.0%	100.0%	☆
P5-19	AI1 input filter time	0.00s~10.00s	0.10s	☆
P5-20	AI2 minimum input value	0.00~P5-22	0.00V	☆
P5-21	AI2 minimum input corresponding setting	-100.0%~100.0%	0.0%	☆
P5-22	AI2 maximum input value	P5-20~10.00V	10.00V	☆
P5-23	AI2 maximum input corresponding setting	-100.0%~100.0%	100.0%	☆
P5-24	AI2 input filter time	0.00s~10.00s	0.10s	☆
P5-25	AI3 minimum input value	0.00V~10.00V	0.00V	☆
P5-26	AI3 minimum input corresponding setting	-100.0%~100.0%	0.0%	☆
P5-27	AI3 maximum input value	0.00V~10.00V	10.00V	☆
P5-28	AI3 maximum input corresponding setting	-100.0%~100.0%	100.0%	☆
P5-29	AI3 input filter time	0.00s~10.00s	0.10s	☆
P5-30	PULSE (pulse) input minimum frequency	0.00KHz~P5-32	0.00KHz	☆
P5-31	PULSE (pulse) input minimum frequency corresponding setting	-100.0%~100.0%	0.0%	☆
P5-32	PULSE (pulse) input maximum frequency	P5-30~50.00KHz	50.00KHz	☆
P5-33	PULSE (pulse) input maximum frequency corresponding setting	-100.0%~100.0%	100.0%	☆
P5-34	PULSE input filter time	0.00s~10.00s	0.10s	☆
P5-35	DI1 turn-on delay time	0.0s~3600.0s	0.0s	☆
P5-36	DI1 off delay time	0.0s~3600.0s	0.0s	☆
P5-37	DI2 turn-on delay time	0.0s~3600.0s	0.0s	☆
P5-38	DI2 off delay time	0.0s~3600.0s	0.0s	☆

Function code	Name	Description (setting range)	Factory Default	Change
P5-39	DI3 turn-on delay time	0.0s~3600.0s	0.0s	☆
P5-40	DI3 off delay time	0.0s~3600.0s	0.0s	☆
p5-41	AI1 is selected as DI terminal function	0~53, the function is the same as the common DI terminal	0	★
p5-42	AI2 is selected as DI terminal function	0~53, the function is the same as the common DI terminal	0	★
P5-44	Valid mode selection when AI is used as DI terminal	Ones place, AI1: 0: Active high, 1: Active low Ten, AI2: 0: Active high, 1: Active low Hundreds: reserved	0x00	☆
P5-45	AI curve selection	AI multi-point curve selection: Ones place: AI1 0: 2-point straight line P5-15~P5-19 1: Multi-point curve 1: PE-00~PE-07 2: Multi-point curve 2: PE-08~PE-15 Tenth place: AI2 0: 2-point straight line P5-20~P5-24 1: Multi-point curve 1: PE-00~PE-07 2: Multi-point curve 2: PE-08~PE-15 Hundreds: reserved	0x00	☆
<b>Group P6: Output terminal</b>				
P6-00	Control board relay RELAY1 output (TA/TB/TC) selection	0: no output 1: Inverter running signal (RUN) 2: fault output 3: Frequency level detection PDT1 arrival 4: Frequency Arrival (PAR) 5: Running at zero speed 6: Motor overload pre-alarm 7: Inverter overload pre-alarm 8: PLC cycle completed	1	☆
P6-01	Control board relay RELAY2 output (RA/RB/RC) selection	9: Cumulative running time arrives 10: Frequency limited	1	☆

## Chapter 5 Function & Parameter Table

Function code	Name	Description (setting range)	Factory Default	Change
P6-02	Y1 output selection	11: Ready to run 12: AI1>AI2 13: The upper limit frequency is reached 14: The lower limit frequency is reached  15: Undervoltage status output 16: Communication settings 17: Timer output 18: Reverse running 19: reserved 20: Set length reached 21: Torque limited 22: Current 1 arrives 23: Frequency 1 arrives 24: Module temperature reached 25: Dropping 26: Cumulative power-on time arrives 27: Timed arrival output 28: The running time has arrived 29: Set count value reached 30: The specified count value arrives 31: Motor 1, Motor 2 indication 32: Brake control output 33: Running at zero speed 2 34: Frequency level detection PDT2 arrival 35: Zero current state 36: Software current overrun 37: The lower limit frequency is reached, and the output is also output when stopped 38: Alarm output 39: Reserved 40: AI1 input overrun 41: Reserved 42: reserved 43: Frequency reached 2 44: Current reaches 2 45: Fault output	1	☆
P6-03	Y2 output selection (optional accessory IO1 support function)	39: Reserved 40: AI1 input overrun 41: Reserved 42: reserved 43: Frequency reached 2 44: Current reaches 2 45: Fault output	1	☆

Function code	Name	Description (setting range)	Factory Default	Change
P6-04	FM terminal output mode selection	0: Pulse output (FMP) 1: Open collector switch output (FMR)	0	☆
P6-05	FMR output selection	Same as Y1 output selection	0	☆
P6-09	AO1 output selection	0: Running frequency 1: set frequency 2: Output current (100% corresponds to twice the rated current of the motor) 3: Output power (100% corresponds to twice the rated power of the motor) 4: Output voltage (100% corresponds to 1.2 times the rated voltage of the inverter) 5: Analog AI1 input value 6: Analog AI2 input value 7: Communication settings	0	☆
P6-10	AO2 output selection	8: Output torque 9: length 10: count value 11: Motor speed 12: Bus voltage (0 to 3 times the rated voltage of the inverter) 13: Pulse input 14: Output current (100% corresponds to 1000.0A) 15: Output voltage (100.0% corresponds to 1000.0V) 16: Output torque (actual torque value - 2 times rated to 2 times rated)	0	☆
P6-11	FMP output selection		0	☆
P6-12	FMP output maximum frequency	0.01KHz~100.00KHz	50.00	☆
P6-13	AO1 output lower limit	-100.0%~P6-15	0.0%	☆
P6-14	The lower limit corresponds to AO1 output	0.00V~10.00V	0.00V	☆
P6-15	AO1 output upper limit	P6-13~100.0%	100.0%	☆

## Chapter 5 Function & Parameter Table

Function code	Name	Description (setting range)	Factory Default	Change
P6-16	The upper limit corresponds to AO1 output	0.00~10.00V	10.00V	☆
P6-17	AO2 output lower limit	-100.0%~P6-19	0.0%	☆
P6-18	The lower limit corresponds to the AO2 output	0.00V~10.00V	0.00V	☆
P6-19	Ao2 output upper limit	P6-17~100.0%	100.0%	☆
P6-20	The upper limit corresponds to AO2 output	0.00~10.00V	10.00V	☆
P6-21	Main relay T pick-up delay	0.0s~3600.0s	0.0s	☆
P6-22	Main relay R pick-up delay	0.0s~3600.0s	0.0s	☆
P6-23	Y1 high level output delay	0.0s~3600.0s	0.0s	☆
P6-26	Main relay T off delay	0.0s~3600.0s	0.0s	☆
P6-27	Main relay R off delay	0.0s~3600.0s	0.0s	☆
P6-28	Y1 low level output delay	0.0s~3600.0s	0.0s	☆
<b>Group P7: Accessibility and keyboard display</b>				
P7-00	Jog running frequency	0.00Hz~Maximum frequency	6.00Hz	☆
P7-01	Jog acceleration time	0.0s~3000.0s	10.0s	☆
P7-02	Jog deceleration time	0.0s~3000.0s	10.0s	☆
P7-03	Acceleration time 2	0.0s~3000.0s	10.0s	☆
P7-04	Deceleration time 2	0.0s~3000.0s	10.0s	☆
P7-05	Acceleration time 3	0.0s~3000.0s	10.0s	☆
P7-06	Deceleration time 3	0.0s~3000.0s	10.0s	☆
P7-07	Acceleration time 4	0.0s~3000.0s	10.0s	☆
P7-08	Deceleration time 4	0.0s~3000.0s	10.0s	☆
P7-09	Hop Frequency 1	0.00Hz~Maximum frequency	0.00Hz	☆
P7-10	Hop Frequency 1 Amplitude	0.00Hz~Maximum frequency	0.00Hz	☆
P7-11	Hop Frequency 2	0.00Hz~Maximum frequency	0.00Hz	☆
P7-12	Hop Frequency 2 Amplitude	0.00Hz~Maximum frequency	0.00Hz	☆
P7-15	Forward and reverse dead time	0.0s~3000.0s	0.0s	☆

Function code	Name	Description (setting range)	Factory Default	Change
P7-16	Keyboard Knob Accuracy	0: default mode 1: 0.1Hz 2: 0.5Hz 3: 1Hz 4: 2Hz 5: 4Hz 6: 5Hz 7: 8Hz 8: 10Hz 9:0.01Hz 10:0.05Hz	2	☆
P7-17	The frequency is lower than the lower limit frequency processing	0: run at the lower frequency limit 1: shutdown 2: Running at zero speed	0	☆
P7-18	Sag rate	0.0%~100.0%	0.0%	☆
P7-19	Delay time for frequency lower than lower limit shutdown	0.0s~600.0s	0.0s	☆
P7-20	Set cumulative operating time	0h~65000h	0h	☆
P7-21	Jog priority	0: invalid 1: Jog priority mode 1 2: Jog priority mode 2 1) When the user fails or the PID is lost, the jog is still valid 2) Stop mode and DC braking can be set	1	☆
P7-22	Frequency detection value (PDT1 level)	0.00Hz~Maximum frequency	50.00Hz	☆
P7-23	Frequency check hysteresis value (PDT1 hysteresis)	0.0%~100.0%	5.0%	☆
P7-24	Frequency arrival detection width	0.0%~100.0%	0.0%	☆
P7-25	Reserve	--	0	●
P7-26	Fan control	0: The fan keeps running 1: The fan runs when the inverter is running	1	★

## Chapter 5 Function & Parameter Table

Function code	Name	Description (setting range)	Factory Default	Change
		(When the temperature is higher than 40°, the fan will also run under shutdown)		
P7-27	STOP/RESET function	0: Only valid in keyboard control 1: The stop or reset function is valid in all control modes	0	☆
P7-28	Quick /JOG key function selection	0: Forward jog 1: Forward and reverse switching 2: Reverse jog 3: Switch between panel and remote control	0	★
P7-29	LED running display	0000~0xPFPF (hexadecimal number) 0000 to 0xPFPF Bit00: Running frequency 0001 Bit01: Set frequency 0002 Bit02: Bus voltage 0004 Bit03: Output voltage 0008 Bit04: Output current 0010 Bit05: Output power 0020 Bit06: DI input status 0040 Bit07: DO output status 0080 Bit08: AI1 voltage 0100 Bit09: AI2 voltage 0200 Bit10: PID setting value 0400 Bit11: PID feedback value 0800 Bit12: Count value 1000 Bit13: Length value 2000 Bit14: Load speed display 4000 Bit15: PLC stage 8000	H.441F	☆
P7-30	LED stop display	1~0x1PFPF (hexadecimal number) Bit00: Set frequency 0001 Bit01: Bus voltage 0002 Bit02: DI input status 0004 Bit03: DO output status 0008 Bit04: AI1 voltage 0010 Bit05: AI2 voltage 0020 Bit06: PID setting value 0040 Bit07: PID feedback value 0080 Bit08: Count value 0100	H.0043	☆

Function code	Name	Description (setting range)	Factory Default	Change
		Bit09: Length value 0200 Bit10: Load speed display 0400 Bit11: PLC stage 0800 Bit12: Input pulse frequency 1000 Bit13 ~Bit15: Reserved		
P7-31	Load speed display factor	0.001~655.00	1.000	☆
P7-32	Radiator temperature	12°C~100°C	Measured value	●
P7-33	Cumulative power-on time	0h~65535h	Measured value	●
P7-34	Cumulative running time	0h~65535h	Measured value	●
P7-36	Current running timing enable selection	0:Disable 1: Enable, When the time is up, a fault is reported 2: Enable, When the time is up, a fault is not reported	0	★
P7-37	Selection of timing source for the current run	0: Digital setting P7-38 1: AI1 2: AI2 (AI takes P7-38 as 100%)	0	★
P7-38	Current running time set value	0.0min~6500.0min	0.0min	☆
P7-39	High level timing	0.0s~6000.0s	2.0s	☆
P7-40	low level timing	0.0s~6000.0s	2.0s	☆
P7-41	Activate the protection function	0: Invalid (start terminal command is valid and start directly) 1: Valid	1	☆
P7-43	Frequency reaches detection value 1	0.00Hz~P0-14	50.00Hz	☆
P7-44	Frequency detection value 1 arrival width	0.0%~100.0%	0.0%	☆
P7-45	Current reaches detection value 1	0.0%~300.0%	100.0%	☆
P7-46	Current detection value 1 arrival width	0.0%~300.0%	0.0%	☆
P7-49	user password	0~65535	0	☆

## Chapter 5 Function & Parameter Table

Function code	Name	Description (setting range)	Factory Default	Change
P7-50	Whether the jump frequency is valid during acceleration and deceleration	0: invalid 1: Valid	0	☆
P7-51	Set the power-on arrival time	0h~65530h	0h	☆
P7-53	Acceleration time 1/2 switching frequency point	0.00Hz~Maximum frequency (P0-14)	0.00Hz	☆
P7-54	Deceleration time 1/2 switching frequency point	0.00Hz~Maximum frequency (P0-14)	0.00Hz	☆
P7-55	Frequency detection value (PDT2 level)	0.00Hz~Maximum frequency (P0-14)	50.00Hz	☆
P7-56	Frequency detection PDT2 hysteresis value	0.0%~100.0%	5.0%	☆
P7-57	Frequency reaches detection value 2	0.00Hz~Maximum frequency (P0-14)	50.00Hz	☆
P7-58	Frequency arrival detection 2 amplitude	0.0%~100.0%	0.0%	☆
P7-59	Zero current detection value	0.0%~300.0%	10.0%	☆
P7-60	Zero current detection delay time	0.01s~300.00s	1.00s	☆
P7-61	Output current amplitude detection	20.0%~400.0%	200.0%	☆
P7-62	Software overcurrent maximum allowable time	0s~6500.0s	0s	☆
P7-63	Current reaches detection value 2	20.0%~300.0%	100.0%	☆
P7-64	Current arrival detection 2 amplitude	0.0%~300.0%	0.0%	☆
P7-65	LED running display parameter 2	0x0~0x1PF Bit00: Target torque% 0001 Bit01: Output torque% 0002 Bit02: Pulse input pulse frequency (KHz) 0004 Bit03: D15 high-speed pulse sampling linear speed (m/min) 0008 Bit04: Motor speed (rpm) 0010		

Function code	Name	Description (setting range)	Factory Default	Change
	LED running display parameter 2	Bit05: AC incoming line current (A) 0020 Bit06: Cumulative running time (h) 0040 Bit07: Current running time (min) 0080 Bit08: Cumulative power consumption (kWh) 0100 Bit09~Bit15: Reserved		
P7-67	AI1 input voltage lower limit	0.00V~P7-68	2.00V	☆
P7-68	AI1 input voltage upper limit	P7-67~11.00V	8.00V	☆
P7-69	Module temperature reached	0°C~90°C	70°C	☆
P7-70	Output power display correction factor	0.001~3.000	1.000	☆
P7-71	Linear velocity display correction factor	Linear speed=P7-71*Number of HDI pulses sampled per second/PB-07	1.000	☆
P7-72	Cumulative power consumption (kWh)	0~65535	Measured value	●
P7-73	Performance software version	Performance software version number	##	●
P7-74	Functional software version	Function software version number	##	●
P7-75	Enhanced function parameter display selection	0: Hide enhanced function parameter group: A0~A3, B0~B5 1: Display enhanced function parameter group: A0~A3, B0~B5	0	☆
P7-76	Motor speed display correction factor	0.0010~3.0000	1.0000	☆
<b>Group P8: Communication parameters</b>				
P8-00	Baud rate setting	0: 300BPS 1: 600BPS 2: 1200BPS 3: 2400BPS	2	☆

## Chapter 5 Function & Parameter Table

Function code	Name	Description (setting range)	Factory Default	Change
		4: 4800BPS 5: 9600BPS 6: 19200BPS 7: 38400BPS		
P8-01	Data Format	0: No parity <8,N,2> 1: Even parity <8,E,1> 2: odd parity <8,O,1> 3: No parity 1<8,N,1>	0	☆
P8-02	Mailing address	0~247 (0 is the broadcast address)	1	☆
P8-03	Response time	0ms~30ms	2ms	☆
P8-04	Communication timeout	0ms~30ms	0.0s	☆
P8-05	Communication format selection	0: Standard ModbusRTU protocol 1: Non-standard ModBusRTU protocol	0	☆
P8-06	Background software monitoring function	0: Disable, default 485 communication function 1: On, the background software monitoring function, the 485 communication function cannot be used at this time	0	☆
<b>Group P9: Fault and Protection</b>				
p9-00	Motor overload protection selection	0: Disable 1: Allow	1	☆
P9-01	Motor overload protection gain	0.10~10.00	1.00	☆
P9-02	Motor overload warning coefficient (%)	50%~100%	80%	☆
P9-03	Overvoltage Stall Protection Gain	000~100	030	☆
P9-04	Overvoltage stall protection voltage	200.0~1200.0V	760.0V	★
P9-05	VF Overcurrent Stall Protection Gain	0~100	20	☆
P9-06	VF Overcurrent Stall Protection Current	50%~200%	150%	★

Function code	Name	Description (setting range)	Factory Default	Change
P9-07	VF field weakening area current stall protection factor	50%~200%	100%	★
P9-08	Oversvoltage stall allowable rise limit value	0.0%~50.0%	10.0%	☆
P9-11	Fault automatic reset times	0~20	0	☆
P9-12	Fault relay action selection during automatic fault reset	0: no action 1: Action	0	☆
P9-13	Fault automatic reset interval time	0.1s~100.0s	1.0s	☆
P9-14	Input phase loss enable selection	0: invalid 1: Valid	1	☆
P9-15	Output phase loss enable selection	0: invalid 1: Valid	1	☆
P9-16	Power-on to ground short-circuit protection selection	0: invalid 1: Valid	1	☆
P9-17	Undervoltage fault automatic reset selection	0: Manual reset is required after undervoltage fault 1: After the undervoltage fault, the fault will be reset by itself according to the bus voltage	0	☆
P9-18	Oversvoltage suppression mode selection	0: invalid 1: Oversvoltage suppression mode 1 2: Oversvoltage suppression mode 2	1	★
P9-19	Overexcitation active state selection	0: invalid 1: Only the deceleration process is valid 2: The constant speed and deceleration process is valid during running	2	★
P9-20	Oversvoltage suppression mode 2 limit value	1.0%~150.0%	10.00%	★

## Chapter 5 Function & Parameter Table

Function code	Name	Description (setting range)	Factory Default	Change
P9-22	Fault protection action 1	<p>0~22202;                      Units place: Motor overload - Err14 0:                      Free parking                      1: stop according to the stop mode 2:                      keep running                      Ten: reserved                      Hundreds place: input phase loss-Err23                      Thousands place: output phase loss-Err24 Ten                      thousand: parameter read and write exception -                      Err25</p>	00000	☆
P9-23	Fault protection action 2	<p>0~22222;                      Ones place: Communication failure - Err27 0:                      Free parking                      1: stop according to the stop mode 2:                      keep running                      Tens place: External fault - Err28                      Hundreds place: excessive speed deviation fault -                      Err29                      Thousands: User-defined fault 1-Err30 Ten                      thousand: user-defined fault 2-Err31</p>	00000	☆
P9-24	Fault protection action 3	<p>0~22222;                      Ones place: PID feedback lost during runtime -                      Err32                      0: Free parking                      1: stop according to the stop mode 2:                      keep running                      Tens place: load loss fault - Err34 Hundreds                      place: software overcurrent - Err16                      Thousands place: The current continuous running                      time reaches -Err39                      Ten thousand: the running time reaches - Err40</p>	00000	☆
P9-26	Continue to run frequency selection in case of failure	<p>0: run at the current operating frequency 1:                      run at the set frequency                      2: run at the upper limit frequency 3:                      Run at the lower frequency limit                      4: Run at the standby frequency setting value P9-                      27</p>	1	☆

Function code	Name	Description (setting range)	Factory Default	Change
P9-27	Abnormal standby frequency set value	0.0%~100.0%	100%	☆
P9-28	Drop load protection option	0: invalid 1: Valid	0	☆
P9-29	Drop load detection level	0.0%~80.0%	20.0%	★
P9-30	Load drop detection time	0.0s~100.0s	5.0s	☆
P9-31	Excessive speed deviation detection value	0.0%~100.0%	20.0%	☆
P9-32	Excessive speed deviation detection time	0.0s~100.0s	0.0s	☆
P9-33	Overspeed detection value	0.0%~100.0%	20.0%	☆
P9-34	Overspeed detection time	0.0s~100.0s	2.0s	☆
P9-35	Motor overload protection current coefficient	100%~200%	100%	☆
P9-36	Motor overheating pre-alarm threshold	0~200°C	80°C	☆
P9-37	Motor overheating protection value	0~200°C	100°C	☆
P9-38	Temperature sensor type selection	0: No temperature sensor 1: PT100 2: PT1000	0	☆
<b>Group PA: PID function</b>				
PA-00	PID setting source	0: Keypad (F10.01) 1: Analog AI1 2: Analog AI2 3: Analog AI3 4: Pulse setting (HDI) 5: Rs485 communication setting 6: Multi-speed command	0	☆
PA-01	PID digital setting	0.0~100.0%	50.0%	☆
PA-02	PID given change time	0.00s~650.00s	0.00s	☆
PA-03	PID feedback source	0: AI1 1: AI2 2: AI1-AI2 3: Communication given	0	☆

## Chapter 5 Function & Parameter Table

Function code	Name	Description (setting range)	Factory Default	Change
		4: PULSE given 5: AI1+AI2 6: MAX( AI1 ,  AI2 ) 7: MIN( AI1 ,  AI2 )		
PA-04	PID action direction	0: Forward action 1: Reverse action	0	☆
PA-05	PID setting feedback range	0~65535	1000	☆
PA-06	Proportional gain P	0.0~100.0	20.0	☆
PA-07	Integral time I	0.01s~10.00s	2.00s	☆
PA-08	Differential time D	0.000s~10.000s	0.000s	☆
PA-09	PID reverse cutoff frequency	0.00~Maximum frequency (PO-14)	0.00Hz	☆
PA-10	Deviation limit	0.0%~100.0%	0.0%	☆
PA-11	Differential clipping	0.00%~100.00%	0.0%	☆
PA-12	PID feedback filter time	0.00~60.00s	0.00s	☆
PA-13	PID feedback loss detection value	0.00~60.00s	0.00s	☆
PA-14	PID feedback loss detection time	0.0s~3600.0s	0s	☆
PA-18	Proportional gain P2	0.0~100.0	20.0	☆
PA-19	Integration time I2	0.01s~10.00s	2.00s	☆
PA-20	Differential time D2	0.000s~10.000s	0.000s	☆
PA-21	PID parameter switching conditions	0: Do not switch 1: DI terminal 2: Automatically switch according to the deviation	0	☆
PA-22	PID parameter switching deviation 1	0.0%~PA-23	20.0%	☆
PA-23	PID parameter switching deviation 2	PA-22~100.0%	80.0%	☆
PA-24	PID initial value	0.0%~100.0%	0.0%	☆
PA-25	PID initial value hold time	0.00s~650.00s	0.00s	☆
PA-26	Twice output deviation positive maximum value	0.00%~100.00%	1.00%	☆

Function code	Name	Description (setting range)	Factory Default	Change
PA-27	Twice output deviation reverse maximum value	0.00%~100.00%	1.00%	☆
PA-28	PID integral properties	Units: Integral separation 0: invalid; 1: Valid Tens place: output to the limit value, whether to stop integration 0: Continue points; 1: Stop integration	00	☆
PA-29	PID shutdown operation	0: stop and do not operate 1: Compute at stop	0	☆
<b>Group Pb: Swing Frequency, Fixed Length and Count</b>				
Pb-00	Swing setting method	0: Relative to the central frequency 1: Relative to the maximum frequency	0	☆
Pb-01	Swing frequency amplitude	0.0%~100.0%	0.0%	☆
Pb-02	Jump frequency amplitude	0.0%~50.0%	0.0%	☆
Pb-03	Swing frequency cycle	0.1s~3000.0s	10.0s	☆
Pb-04	Triangular wave rising time coefficient	0.1%~100.0%	50.0%	☆
Pb-05	Set length	0m~65535m	1000m	☆
Pb-06	Actual length	0m~65535m	0m	☆
Pb-07	Number of pulses per meter	0.1~6553.5	100.0	☆
Pb-08	Set count value	1~65535	1000	☆
Pb-09	Designated count value	1~65535	1000	☆
<b>Group PC: Multi-segment instruction and simple PLC function</b>				
PC-00	Multi-speed 0	-100.0%~100.0%	0.0%	☆
PC-01	Multi-speed 1	-100.0%~100.0%	0.0%	☆
PC-02	Multi-speed 2	-100.0%~100.0%	0.0%	☆
PC-03	Multi-speed 3	-100.0%~100.0%	0.0%	☆
PC-04	Multi-speed 4	-100.0%~100.0%	0.0%	☆
PC-05	Multi-speed 5	-100.0%~100.0%	0.0%	☆
PC-06	Multi-speed 6	-100.0%~100.0%	0.0%	☆

## Chapter 5 Function & Parameter Table

Function code	Name	Description (setting range)	Factory Default	Change
PC-07	Multi-speed 7	-100.0%~100.0%	0.0%	☆
PC-08	Multi-speed 8	-100.0%~100.0%	0.0%	☆
PC-09	Multi-speed 9	-100.0%~100.0%	0.0%	☆
PC-10	Multi-speed 10	-100.0%~100.0%	0.0%	☆
PC-11	Multi-speed 11	-100.0%~100.0%	0.0%	☆
PC-12	Multi-speed 12	-100.0%~100.0%	0.0%	☆
PC-13	Multi-speed 13	-100.0%~100.0%	0.0%	☆
PC-14	Multi-speed 14	-100.0%~100.0%	0.0%	☆
PC-15	Multi-speed 15	-100.0%~100.0%	0.0%	☆
PC-16	PLC operation mode	0: Stop at the end of a single operation 1: Hold the final value for a single run 2: keep looping	0	☆
PC-17	PLC power-down memory selection	0: No memory when power off and no memory when stopped 1: Memory when power off and no memory when stopped 2: No memory when power off and memory when shut down 3: Power-down memory and shutdown memory	0	☆
PC-18	Running time of simple PLC multi-speed 0	0.0s(h)~6500.0s(h)	0.0s(h)	☆
PC-19	Acceleration/deceleration time of simple PLC multi-speed 0	0~3	0	☆
PC-20	Running time of simple PLC multi-speed 1	0.0s(h)~6500.0s(h)	0.0s(h)	☆
PC-21	Acceleration/deceleration time of simple PLC multi-speed 1	0~3	0	☆
PC-22	Running time of simple PLC multi-speed 2	0.0s(h)~6500.0s(h)	0.0s(h)	☆

Function code	Name	Description (setting range)	Factory Default	Change
PC-23	Acceleration/deceleration time of simple PLC multi-speed 2	0~3	0	☆
PC-24	Running time of simple PLC multi-speed 3	0.0s(h)~6500.0s(h)	0.0s(h)	☆
PC-25	Acceleration/deceleration time of simple PLC multi-speed 3	0~3	0	☆
PC-26	Running time of simple PLC multi-speed 4	0.0s(h)~6500.0s(h)	0.0s(h)	☆
PC-27	Acceleration/deceleration time of simple PLC multi-speed 4	0~3	0	☆
PC-28	Running time of simple PLC multi-speed 5	0.0s(h)~6500.0s(h)	0.0s(h)	☆
PC-29	Acceleration/deceleration time of simple PLC multi-speed 5	0~3	0	☆
PC-30	Running time of simple PLC multi-speed 6	0.0s(h)~6500.0s(h)	0.0s(h)	☆
PC-31	Acceleration/deceleration time of simple PLC multi-speed 6	0~3	0	☆
PC-32	Running time of simple PLC multi-speed 7	0.0s(h)~6500.0s(h)	0.0s(h)	☆
PC-33	Acceleration/deceleration time of simple PLC multi-speed 7	0~3	0	☆
PC-34	Running time of simple PLC multi-speed 8	0.0s(h)~6500.0s(h)	0.0s(h)	☆
PC-35	Acceleration/deceleration time of simple PLC multi-speed 8	0~3	0	☆
PC-36	Running time of simple PLC multi-speed 9	0.0s(h)~6500.0s(h)	0.0s(h)	☆

## Chapter 5 Function & Parameter Table

Function code	Name	Description (setting range)	Factory Default	Change
PC-37	Acceleration/deceleration time of simple PLC multi-speed 9	0~3	0	☆
PC-38	Running time of simple PLC multi-speed 10	0.0s(h)~6500.0s(h)	0.0s(h)	☆
PC-39	Acceleration/deceleration time of simple PLC multi-speed 10	0~3	0	☆
PC-40	Running time of simple PLC multi-speed 11	0.0s(h)~6500.0s(h)	0.0s(h)	☆
PC-41	Acceleration/deceleration time of simple PLC multi-speed 11	0~3	0	☆
PC-42	Running time of simple PLC multi-speed 12	0.0s(h)~6500.0s(h)	0.0s(h)	☆
PC-43	Acceleration/deceleration time of simple PLC multi-speed 12	0~3	0	☆
PC-44	Acceleration/deceleration time of simple PLC multi-speed 13	0~3	0	☆
PC-45	Running time of simple PLC multi-speed 14	0.0s(h)~6500.0s(h)	0.0s(h)	☆
PC-46	Acceleration/deceleration time of simple PLC multi-speed 14	0~3	0	☆
PC-47	Running time of simple PLC multi-speed 15	0.0s(h)~6500.0s(h)	0.0s(h)	☆
PC-48	Acceleration/deceleration time of simple PLC multi-speed 15	0~3	0	☆
PC-49	Running time of simple PLC multi-speed 15	0.0s(h)~6500.0s(h)	0.0s(h)	☆
PC-50	Time unit of multi-speed	0: s (second) 1:h (hour)	0	☆

Function code	Name	Description (setting range)	Factory Default	Change
PC-51	Multi-speed priority mode selection	0: Multi-speed does not have priority 1: Multi-speed priority	1	☆
PC-52	Multi-speed priority acceleration and deceleration time selection	0: Acceleration and deceleration time 1 1: Acceleration and deceleration time 2 2: Acceleration and deceleration time 3 3: Acceleration and deceleration time 4	0	☆
PC-53	Multi-speed PC-00~PC-15 unit selection	0: % 1: Hz	0	☆
PC-55	Multi-segment instruction 0 given mode	0: Function code PC-00 given 1: AI1 2: AI2 3: PULSE pulse 4: PID 5: Preset frequency given (PO-11), UP/DOWN can be modified	0	☆
<b>Group PD: Torque control</b>				
PD-00	Torque command source selection	0: Digital setting (PD-01) 1: AI1 2: AI2 3: Communication given 4: PULSE pulse frequency setting 5: MIN (AI1, AI2) 6: MAX (AI1, AI2) (1-6 option full scale corresponds to PD-01)	0	★
PD-01	Torque digital given	-200.0%~200.0%	150.0%	☆
PD-03	Torque control positive direction maximum frequency	0.00Hz~Maximum frequency (PO-14)	50.00Hz	☆
PD-04	Torque control reverse direction maximum frequency	0.00Hz~Maximum frequency (PO-14)	50.00Hz	☆

## Chapter 5 Function & Parameter Table

Function code	Name	Description (setting range)	Factory Default	Change
PD-06	Torque command filter time	0.00s~10.00s	0.00s	☆
PD-07	Torque mode frequency acceleration time	0.0s~1000.0s	10.0s	☆
PD-08	Torque mode frequency deceleration time	0.0s~1000.0s	10.0s	☆
PD-10	Speed/torque mode selection	0: Speed mode 1: Torque mode	0	★
<b>Group PE: AI multi-point curve setting</b>				
PE-00	Curve 1 minimum input	-10.00V~PE-02	0.00V	☆
PE-01	Curve 1 minimum input corresponding setting	-100.0%~100.0%	0.0%	☆
PE-02	Curve 1 Knee 1 Input	PE-00~PE-04	3.00V	☆
PE-03	Curve 1 inflection point 1 input corresponding setting	-100.0%~100.0%	30.0%	☆
PE-04	Curve 1 Knee 2 Input	PE-02~PE-06	6.00V	☆
PE-05	Curve 1 inflection point 2 input corresponding setting	-100.0%~100.0%	60.0%	☆
PE-06	Curve 1 maximum input	PE-04~10.00	10.00V	☆
PE-07	Curve 1 maximum input corresponding setting	-100.0%~100.0%	100.0%	☆
PE-08	Curve 2 minimum input	-10.00~PE-10	0.00V	☆
PE-09	Curve 2 minimum input corresponding setting	-100.0%~100.0%	0.0%	☆
PE-10	Curve 2 Knee 1 Input	PE-08~PE-12	3.00V	☆
PE-11	Curve 2 inflection point 1 input corresponding setting	-100.0%~100.0%	30.0%	☆
PE-12	Curve 2 Knee 2 Input	PE-10~PE-14	6.00V	☆
PE-13	Curve 2 inflection point 2 input corresponding setting	-100.0%~100.0%	60.0%	☆
PE-14	Curve 2 maximum input	PE-12~10.00V	10.00V	☆
PE-15	Curve 2 maximum input corresponding setting	-100.0%~100.0%	100.0%	☆
PE-24	AI1 set jump point	-100.0%~100.0%	0.0%	☆
PE-25	AI1 sets the jump range	0.0%~100.0%	0.5%	☆

Function code	Name	Description (setting range)	Factory Default	Change
PE-26	AI2 set jump point	-100.0%~100.0%	0.0%	☆
PE-27	AI2 set jump range	0.0%~100.0%	0.5%	☆
<b>Group PF: Manufacturer parameters</b>				
PF.00	Factory password	0~65535	*****	☆
<b>Group A0: Second motor parameter setting</b>				
A0-00	Motor selection	1: Motor No. 1 2: Motor No. 2	1	★
A0-01	The second motor control mode	1: Open loop vector control (speed sensorless vector) 2: VF Control	2	★
A0-02	Second motor acceleration and deceleration time selection	0: Consistent with the first motor 1: Acceleration and deceleration time 1 2: Acceleration and deceleration time 2 3: Acceleration and deceleration time 3 4: Acceleration and deceleration time 4	0	☆
<b>Group A1: Second Motor Parameters</b>				
A1-00	Motor parameter tuning	0: no function 1: Static tuning 2: Dynamic full tuning	0	★
A1-01	Motor 2 rated power	0.1Kw~1000.0Kw	Model is determined	★
A1-02	Motor 2 rated voltage	1V~1500V	380V	★
A1-03	Motor 2 Number of motor poles	2 to 64	Model is determined	●
A1-04	Motor 2 rated current	0.01A~600.00A(Motor rated power<=30.0KW) 0.1A~6000.0A(Motor rated power>30.0KW)	A1-01 OK	★
A1-05	Motor 2 rated frequency	0.01Hz~Maximum frequency (P0-14)	50.00Hz	★
A1-06	Motor 2 rated speed	1rpm~65535rpm	A1-01 OK	★

## Chapter 5 Function & Parameter Table

Function code	Name	Description (setting range)	Factory Default	Change
A1-07	Motor 2 no-load current	0.01A~A1-04 (Motor rated power<=30.0KW) 0.1A~A1-04 (Motor rated power>30.0KW)	A1-01 OK	★
A1-08	Motor 2 stator resistance	0.001ohm~65.535ohm	Model is determined	★
A1-09	Motor 2 rotor resistance	0.001ohm~65.535ohm	Model is determined	★
A1-10	Motor 2 mutual inductance	0.1mH~6553.5mH	Model is determined	★
A1-11	Motor 2 leakage inductance	0.01mH~655.35mH	Model is determined	★
A1-12	Acceleration at Dynamic Full Tuning	1.0s~6000.0s	10.0s	☆
A1-13	Deceleration at dynamic full tuning	1.0s~6000.0s	10.0s	☆
<b>Group A2: Second motor VF parameter setting</b>				
A2-00	Torque boost	0.0%~30.0%	0.0%	☆
A2-01	Oscillation suppression gain	0~100	Model is determined	☆
<b>Group A3: Second motor vector control parameters</b>				
A3-00	Switching frequency P1	0.00Hz~A3-02	5.00Hz	☆
A3-02	Switching frequency P2	A3-00~P0-14	10.00Hz	☆
A3-04	Low frequency speed proportional gain	0.1~10.0	4.0	☆
A3-05	Low frequency speed integration time	0.01s~10.00s	0.50s	☆
A3-06	High frequency speed proportional gain	0.1~10.0	2.0	☆
A3-07	High frequency speed integration time	0.01s~10.00s	1.00s	☆
A3-08	Speed loop integral attribute selection	0: Points take effect 1: Integral separation	0	★
A3-11	Torque current regulator Kp	0~30000	2000	☆
A3-12	Torque current regulator Ki	0~30000	1300	☆

Function code	Name	Description (setting range)	Factory Default	Change
A3-13	Excitation current regulator Kp	0~30000	2000	☆
A3-14	Excitation current regulator Ki	0~30000	1300	☆
A3-15	Flux Brake Gain	0~200	0	☆
A3-16	Field weakening torque correction factor	50%~200%	100%	☆
A3-17	Slip Compensation Coefficient	50%~200%	100%	☆
A3-18	Speed loop feedback filter time constant	0.000s~1.000s	0.015s	☆
A3-19	Speed loop output filter time constant	0.000s~1.000s	0.000s	☆
A3-20	Electric torque upper limit source	0: P3-21 2: AI2 1: AI1 (analog range corresponds to P3-21) 3: Communication given 4: PLUSE given	0	☆
A3-21	Electric torque upper limit	0.0%~200.0%	150.0%	☆
A3-22	Braking torque upper limit source	0: P3-23 2: AI2 1: AI1 (analog range corresponds to P3-23) 3: Communication given 4: PLUSE given	0	☆
A3-23	Braking torque upper limit	0.0%~200.0%	150%	☆
<b>Group B0: System parameters</b>				
B0-00	Function code read-only selection	0: invalid 1: read only	0	☆
B0-01	LCD top menu display/LED second line display	0: output current 1: Motor speed 2: Load speed 3: Output voltage 4: PID given 5: PID feedback	0	☆

## Chapter 5 Function & Parameter Table

Function code	Name	Description (setting range)	Factory Default	Change
B0-02	LCD language selection	0: Chinese 1: English	0	☆
B0-03	LED menu toggle selection	0: Disable 1: enable	0	☆
B0-04	Vector operating frequency display selection	0: real-time frequency 1: set frequency	0	☆
B0-05	Display selection during UP/Down adjustment	0: Display the set value 1: Display the current variable value	0	☆
<b>Group B1: User function code customization</b>				
B1-00	Clear custom function code selection	0: invalid 1: Valid	0	☆
B1-01	Custom function code 1	uP0-00~uU1-xx	uP0-03	☆
B1-02	Custom function code 2	uP0-00~uU1-xx	uP0-04	☆
B1-03	Custom function code 3	uP0-00~uU1-xx	uP0-06	☆
B1-04	Custom function code 4	uP0-00~uU1-xx	uP0-23	☆
B1-05	Custom function code 5	uP0-00~uU1-xx	uP0-24	☆
B1-06	Custom function code 6	uP0-00~uU1-xx	uP4-00	☆
B1-07	Custom function code 7	uP0-00~uU1-xx	uP4-01	☆
B1-08	Custom function code 8	uP0-00~uU1-xx	uP4-02	☆
B1-09	Custom function code 9	uP0-00~uU1-xx	uP4-04	☆
B1-10	Custom function code 10	uP0-00~uU1-xx	uP4-05	☆
B1-11	Custom function code 11	uP0-00~uU1-xx	uP4-06	☆
B1-12	Custom function code 12	uP0-00~uU1-xx	uP4-12	☆
B1-13	Custom function code 13	uP0-00~uU1-xx	uP4-13	☆
B1-14	Custom function code 14	uP0-00~uU1-xx	uP5-00	☆
B1-15	Custom function code 15	uP0-00~uU1-xx	uP5-01	☆
B1-16	Custom function code 16	uP0-00~uU1-xx	uP5-02	☆
B1-17	Custom function code 17	uP0-00~uU1-xx	uP6-00	☆
B1-18	Custom function code 18	uP0-00~uU1-xx	uP6-01	☆

Function code	Name	Description (setting range)	Factory Default	Change
B1-19	Custom function code 19	uP0-00~uU1-xx	uP0-00	☆
B1-20	Custom function code 20	uP0-00~uU1-xx	uP0-00	☆
B1-21	Custom function code 21	uP0-00~uU1-xx	uP0-00	☆
B1-22	Custom function code 22	uP0-00~uU1-xx	uP0-00	☆
B1-23	Custom function code 23	uP0-00~uU1-xx	uP0-00	☆
B1-24	Custom function code 24	uP0-00~uU1-xx	uP0-00	☆
B1-25	Custom function code 25	uP0-00~uU1-xx	uP0-00	☆
B1-26	Custom function code 26	uP0-00~uU1-xx	uP0-00	☆
B1-27	Custom function code 27	uP0-00~uU1-xx	uP0-00	☆
B1-28	Custom function code 28	uP0-00~uU1-xx	uP0-00	☆
B1-29	Custom function code 29	uP0-00~uU1-xx	uP0-00	☆
B1-30	Custom function code 30	uP0-00~uU1-xx	uP0-00	☆
B1-31	Custom function code 31	uP0-00~uU1-xx	uP0-00	☆
<b>Group B2: Optimize control parameters</b>				
B2-00	Dead Time Compensation Enable Selection	0: no compensation 1: Compensation	1	☆
B2-01	PWM method	0: Asynchronous modulation 1: Synchronous modulation	0	☆
B2-02	PWM seven-segment/five-segment selection	0: 7 segments in the whole process 1: Seven-segment/five-segment automatic switching	0	☆
B2-03	CBC current limit enable selection	0: Disable 1: enable	1	☆
B2-04	Braking point	330.0V~1200.0V	360.0V 690.0V	☆
B2-05	Undervoltage point	150.0V~820.0V	200.0V 350.0V	☆
B2-06	Random PWM depth setting	0~6	0	☆

## Chapter 5 Function & Parameter Table

Function code	Name	Description (setting range)	Factory Default	Change
B2-07	0Hz operating mode selection	0: No current output; 1: Normal operation; 2: Output with stop DC braking current P1-16;	0	☆
B2-08	Low frequency carrier limitation mode selection	0: limit mode 0 1: Restricted Mode 1 2: Unlimited (the carrier of all frequency bands is the same)	0	☆
<b>Group B3: AIAO correction parameters</b>				
B3-00	AI1 shows voltage 1	-9.999V~10.000V	3.000V	☆
B3-01	AI1 measured voltage 1	-9.999V~10.000V	3.000V	☆
B3-02	AI1 shows voltage 2	-9.999V~10.000V	8.000V	☆
B3-03	AI1 measured voltage 2	-9.999V~10.000V	8.000V	☆
B3-04	AI2 shows voltage 1	-9.999V~10.000V	3.000V	☆
B3-05	AI2 measured voltage 1	-9.999V~10.000V	3.000V	☆
B3-06	AI2 shows voltage 2	-9.999V~10.000V	8.000V	☆
B3-07	AI2 measured voltage 2	-9.999V~10.000V	8.000V	☆
B3-12	AO1 target voltage 1	-9.999V~10.000V	3.000V	☆
B3-13	AO1 measured voltage 1	-9.999V~10.000V	3.000V	☆
B3-14	AO1 target voltage 2	-9.999V~10.000V	8.000V	☆
B3-15	AO1 measured voltage 2	-9.999V~10.000V	8.000V	☆
B3-16	AO2 target voltage 1	-9.999V~10.000V	3.000V	☆
B3-17	AO2 measured voltage 1	-9.999V~10.000V	3.000V	☆
B3-18	AO2 target voltage 2	-9.999V~10.000V	8.000V	☆
B3-19	AO2 measured voltage 2	-9.999V~10.000V	8.000V	☆
<b>Group B4: Master-slave control parameters</b>				
B4-00	Master-slave control enable selection:	0: Disable 1: Enable	0	★
B4-01	Master-slave selection:	0: Host 1: Slave	0	★

Function code	Name	Description (setting range)	Factory Default	Change
B4-02	Host sending frequency selection:	0: Running frequency 1: Target frequency	0	★
B4-03	Slave follow master command source selection	0: Do not follow 1: Follow	0	★
B4-04	Slave receive frequency coefficient	0.00%~600.00%	100.00%	☆
B4-05	Slave receives torque coefficient	-10.00~10.00	1.00	☆
B4-06	Slave receives torque bias	-50.00%~50.00%	0.00%	☆
B4-07	Frequency deviation threshold	0.20%~10.00%	0.50%	☆
B4-08	Master-slave communication drop detection time	0.00s~10.0s	0.1s	☆
<b>Group B5: Brake function parameters</b>				
B5-00	Brake control enable selection:	0: Disable 1: Enable	0	★
B5-01	brake release frequency	0.00Hz~20.00Hz	2.50Hz	★
B5-02	Brake release frequency maintenance time	0.0s~20.0s	1.0s	★
B5-03	Current limit value during holding brake	50.0%~200.0%	120.0%	★
B5-04	Brake pull-in frequency	0.00Hz~20.00Hz	1.50Hz	★
B5-05	Brake pull-in delay time	0.0s~20.0s	0.0s	★
B5-06	Holding time of brake pull-in frequency	0.0s~20.0s	1.0s	★
<b>Group B6: Sleep wakeup function parameters</b>				
B6-00	Hibernate selection	0: The sleep function is invalid 1: Digital input terminal DI controls sleep function 2: The sleep function is controlled by the PID setting value and feedback value 3: Control the sleep function according to the operating frequency	0	☆

## Chapter 5 Function & Parameter Table

Function code	Name	Description (setting range)	Factory Default	Change
B6-01	Sleep frequency	0.00Hz~P0-14	0.00Hz	☆
B6-02	Sleep delay	0.0s~3600.0s	20.0s	☆
B6-03	Wake-up difference	0.0%~100.0% When B6-00=3, the unit becomes Hz	10.0%	☆
B6-04	Wake up delay	0.0s~3600.0s	0.5s	☆
B6-05	Sleep delay frequency output selection	0: PID automatic adjustment 1: Sleep frequency B6-01	0	☆

Function code	Name	Description (setting range)	Smallest unit	Change
<b>Group U0: Fault logging parameters</b>				
U0-00	Last failure type	00: No fault Err01: Inverter module protection Err04: Overcurrent during acceleration Err05: Overcurrent during deceleration Err06: Overcurrent during constant speed operation Err08: Overvoltage during acceleration Err09: Overvoltage during deceleration Err10: Overvoltage during constant speed operation Err12: Undervoltage fault Err13: Drive overload fault Err14: Motor overload fault Err15: Drive overheated Err17: Current detection failure Err20: Short circuit fault to ground Err23: Input phase loss fault Err24: output phase loss fault Err25: Eeprom operation failure Err27: Communication failure Err28: External fault Err29: The speed deviation is too large Err30: User-defined fault 1 Err31: User-defined fault 2	1	●
U0-01	Last failure type		1	●
U0-02	Types of first and second faults		1	●

Function code	Name	Description (setting range)	Smallest unit	Change
		Err33: Fast current limiting Err34: load drop fault Err32: PID feedback lost during runtime Err35: Input power failure Err37: parameter storage exception Err39: The running time has arrived Err40: Cumulative running time reached Err42: Switch the motor during operation Err46: Master-slave control communication dropped		
U0-03	Frequency of last failure		0.01Hz	●
U0-04	Current at last fault		0.01A	●
U0-05	Bus voltage at last fault		0.1V	●
U0-06	Input terminal status at the last fault		1	●
U0-07	Output terminal status at the last fault		1	●
U0-08	Last fault inverter status		1	●
U0-09	Running time at the last fault (starting time after power-on, minutes)		1min	●
U0-10	Running time at the last failure (time from running time, minutes)		1min	●
U0-13	Frequency at last failure		0.01Hz	●
U0-14	Current at previous fault		0.01A	●
U0-15	Bus voltage at previous fault		0.1V	●
U0-16	Input terminal at the previous fault		1	●
U0-17	Output terminal when the previous fault		1	●
U0-18	Last fault inverter status		1	●
U0-19	The running time of the previous fault (start timing after power-on, minutes)		1min	●
U0-20	Time of last failure (timed from runtime, minutes)		1min	●
U0-21	reserved variable		--	●
U0-22	reserved variable		-	●
U0-23	The frequency of the first and second faults		0.01Hz	●

## Chapter 5 Function & Parameter Table

Function code	Name	Smallest unit	Change
U0-24	Current at the first and second faults	0.01A	●
U0-25	Bus voltage at the first and second faults	0.1V	●
U0-26	Input terminal for the first and second faults	1	●
U0-27	Output terminal when the first and second faults	1	●
U0-28	Inverter status of previous and second faults	1	●
U0-29	The running time of the first and second faults (start timing after power-on, minutes)	1min	●
U0-30	The time of the first and second failures (timed from the running time, minutes)	1min	●
<b>Group U1: Application Monitoring Parameters</b>			
U1-00	Operating frequency (Hz)	0.01Hz	●
U1-01	Set frequency (Hz)	0.01Hz	●
U1-02	Bus voltage (V)	0.1V	●
U1-03	Output voltage (V)	1V	●
U1-04	Output current (A)	0.1A	●
U1-05	Output power (Kw)	0.1kW	●
U1-06	DI input status, hexadecimal number	1	●
U1-07	DO output status, hexadecimal number	1	●
U1-08	Voltage after AI1 correction	0.01V	●
U1-09	Voltage after AI2 correction	0.01V	●
U1-10	PID set value, PID set value (percentage)*PA-05	1	●
U1-11	PID feedback, PID feedback value (percentage)*PA-05	1	●
U1-12	Count value	1	●
U1-13	Length value	1	●
U1-14	Motor speed	rpm	●
U1-15	PLC stage, the current segment during multi-speed operation	1	●
U1-16	PULSE pulse input frequency	0.01kHz	●
U1-17	Feedback speed, the actual operating frequency of the motor	0.1Hz	●

Function code	Name	Smallest unit	Change
U1-18	P7-38 Remaining time of timing time	0.1Min	●
U1-19	AI1 voltage before correction	0.001V	●
U1-20	Voltage before AI2 correction	0.001V	●
U1-21	DI5 high-speed pulse sampling line speed, refer to P7-71 for use	1m/min	●
U1-22	Load speed display (set load speed when stopped), refer to P7-31 for use	customize	●
U1-23	The power-on time	1Min	●
U1-24	This running time	0.1Min	●
U1-25	PULSE pulse input frequency, different from U1-16 only in unit	1Hz	●
U1-26	Communication setting frequency value	0.01%	●
U1-27	Main frequency display	0.01Hz	●
U1-28	Auxiliary frequency display	0.01Hz	●
U1-29	Target torque, take the motor rated torque as 100%	0.1%	●
U1-30	Output torque, take the motor rated torque as 100%	0.1%	●
U1-31	Output torque, with the rated current of the inverter as 100%	0.1%	●
U1-32	Torque upper limit, the rated current of the inverter is 100%	0.1%	●
U1-33	VF separation target voltage	1V	●
U1-34	VF split output voltage	1V	●
U1-35	Reserve	—	●
U1-36	Motor serial number currently in use	1	●
U1-37	AO1 target voltage	0.01V	●
U1-38	AO2 target voltage	0.01V	●
U1-39	Inverter running status, 0: Stop, 1: Forward, 2: Reverse, 3: Fault	1	●
U1-40	Inverter current fault	1	●

## Chapter 5 Function & Parameter Table

Function code	Name	Smallest unit	Change
U1-41	Agent time remaining	1h	●
U1-42	AC incoming line current	0.1A	●
U1-43	PLC current phase remaining time	0.1	●
U1-47	Cumulative running time 1 (cumulative running time = U1-47 + U1-48)	1h	●
U1-48	Cumulative running time 2 (cumulative running time = U1-47 + U1-48)	1min	●
U1-50	Motor temperature	1°C	●



Chapter 6

**Function & Parameter Table**

**Group P0: Basic function group**

Function code	Name	Description (setting range)	Factory Default	Change
P0-00	Product number	Product model: 5 digits display, 2 decimal places	60#.##	●

It can only be viewed by the user and cannot be modified.

Function code	Name	Description (setting range)	Factory Default	Change
P0-01	Inverter GP type display	0~1	0	★

0: G type, suitable for constant torque load with specified rated parameters.

1: P type, suitable for variable torque loads (fans, pumps, etc.) with specified rated parameters.

Function code	Name	Description (setting range)	Factory Default	Change
P0-02	Rated current	0.1A~3000.0A	Model is determined	●

It is only for users to check the rated current of the drive and cannot be modified.

Function code	Name	Description (setting range)	Factory Default	Change
P0-03	Motor control method	1~2	2	★

**Ones place: motor control mode selection**

1: Open loop vector control (speed sensorless vector) 2: VF Control

3: Closed loop vector (with speed sensor vector)

**Tens place: motor type selection**

0: Asynchronous motor

1: Synchronous motor

Function code	Name	Description (setting range)	Factory Default	Change
P0-04	Run command source	0~2	0	★

Select the input channel of the inverter control command.

Inverter control commands include: start, stop, forward, reverse, jog, etc.

**0: Operation panel command channel ("L/D/C" light flashes);**

The operation command is controlled by the RUN, STOP/RES buttons on the operation panel.

**1: Terminal command channel ("L/D/C" light flashes);**

The running command is controlled by the multi-function input terminals FWD, REV, JOGF, JOGR, etc.

**2: Communication command channel ("L/D/C" light flashes)**

The running command is given by the upper computer through communication.

Function code	Name	Description (setting range)	Factory Default	Change
P0-05	Up\Down to modify the frequency command reference during runtime	0~1	1	★

**0: Running frequency**

**1: set frequency**

This parameter is only valid when the frequency source is digitally set. It is used to determine whether to modify the set frequency or the running frequency when the key up/Down or the terminal up/Down action is performed. The biggest difference is mainly reflected in the acceleration and deceleration process.

Function code	Name	Description (setting range)	Factory Default	Change
P0-06	Main frequency source X selection	0~8	1	★

Select the input channel of the main given frequency of the inverter. There are 9 main reference frequency channels:

**0: Up/Down modification frequency will not be remembered when shutdown**

The initial value is the value of P0-11 "Digital setting preset frequency".

The set frequency value of the inverter can be changed through the increase and decrease keys of the keyboard (or the UP and DOWN of the multi-function input terminal). No memory at stop means that after the inverter stops, it does not remember the changed frequency setting value of the inverter. After the inverter stops, the set frequency value returns to the value of P0-11 "digital setting preset frequency".

**1: Up/Down modification frequency power-down memory**

The initial value is the value of P0-11 "Digital setting preset frequency".

The set frequency value of the inverter can be changed through the increase and decrease keys of the keyboard (or the UP and DOWN of the multi-function input terminal).

Power-off means that when the inverter is powered on again after power-off, the set frequency is the set frequency before the last power-off.

### **2: AI1**

### **3: AI2**

It means that the frequency is determined by the analog input terminal. KD600 control board provides 2 analog input terminals (AI1, AI2)

Among them: AI1 is 0V~10V voltage input, AI2 can be 0V~10V voltage input, or 0mA~20mA current input, which is selected by the dial switch on the control board.

The input voltage value of AI1, AI2, and the corresponding relationship curve of the target frequency, the user can freely choose through P5-45.

KD600 provides 4 sets of corresponding relationship curves, of which 2 sets of curves are straight-line relationships (2-point correspondence), and 2 sets of curves are arbitrary curves with 4-point correspondence. Users can use P5-15~P5-24 function codes and PE group code to set.

Function code P5-45 is used to set the two analog inputs of AI1~AI2, and select which group of the 4 groups of curves respectively.

When AI is used as a given frequency, the voltage/current input corresponds to 100.0% of the set value, which refers to the percentage relative to the maximum output frequency P0-14.

### **4: Multi-speed**

Select the multi-speed running mode. It is necessary to set the P5 group "input terminal" and PC group "multi-speed and PLC" parameters to determine the corresponding relationship between the given signal and the given frequency.

### **5: Simple PLC**

Select Simple PLC mode. When the frequency source is a simple PLC, it is necessary to set the PC group "multi-speed and PLC" parameters to determine the given frequency.

### **6: PID**

Select Process PID Control. At this time, it is necessary to set the PA group "PID function". The operating frequency of the inverter is the frequency value after PID action. For the meaning of PID reference source, reference value, feedback source, etc., please refer to the introduction of "PID function" in group PA-

### **7: Communication given**

It means that the main frequency source is given by the host computer through communication (see Appendix A KD600 MODBUS Communication Protocol for details).

### **8: PULSE pulse frequency given**

The given pulse frequency of PULSE is input from the HDI terminal of the control board, and the given pulse ramp can be determined by the settings of P5-30~P5-34.

Function code	Name	Description (setting range)	Factory Default	Change
P0-07	Auxiliary frequency source Y selection	0~8	0	★

When the auxiliary frequency source is used as an independent frequency reference channel, its usage is the same as that of the main frequency source X.

When the auxiliary frequency source is used as the superposition reference (the one digit of P0-10 is 1, 2, 3, 4), it has the following special features:

1. When the auxiliary frequency source is a digital reference, the preset frequency (P0-11) does not work. It can be performed on the basis of the main reference frequency through the increase and decrease keys of the keyboard (or UP and DOWN of the multi-function input terminal). Adjust up and down.

2. When the auxiliary frequency source is given by analog input (AI1, AI2), 100% of the input setting corresponds to the range of auxiliary frequency source (see the description of P0-08 and P0-09). If you need to adjust up and down on the basis of the main given frequency, please set the corresponding setting range of the analog input to -n% to +n% (refer to the description of P5-15 to P5-24).

Tip: The auxiliary frequency source Y selection cannot be the same as the main frequency source X setting value, that is, the main and auxiliary frequency sources cannot use the same frequency given channel.

Function code	Name	Description (setting range)	Factory Default	Change
P0-08	Auxiliary frequency source Y range selection	0~1	0	☆

**0: relative to the maximum frequency;**

**1: relative to frequency source X;**

P0-08 is used to determine the relative object of this range. If it is relative to the maximum frequency (P0-14), its range is a fixed value. If it is relative to the main frequency source X, its range will change with the main frequency X, and change.

Function code	Name	Description (setting range)	Factory Default	Change
P0-09	Auxiliary frequency source Y range	0% to 100%	100%	☆

When the frequency source is selected as frequency superposition given (refer to P0-10 setting), it is used to determine the adjustment range of the auxiliary frequency source.

Function code	Name	Description (setting range)	Factory Default	Change
P0-10	Frequency source selection	Ones place: 0~4 Tens place: 0~3	00	☆

Use this parameter to select the frequency given channel. The frequency setting is realized by the combination of the main frequency source X and the auxiliary frequency source Y.

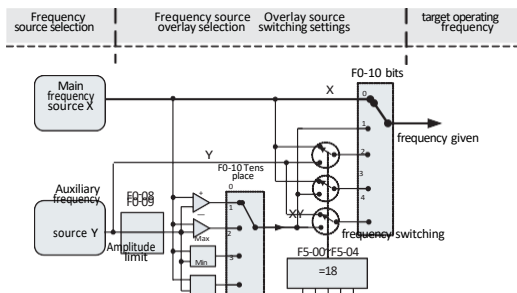

Figure 6-1. Schematic diagram of frequency source superposition

**Ones place: Frequency source selection:**

#### 0: Main frequency source X

The main frequency X is used as the target frequency.

#### 1: Main and auxiliary operation results

The main and auxiliary operation results are used as the target frequency, and the relationship between the main and auxiliary operations is shown in the "tens" description of this function code.

#### 2: Switch between main frequency source X and auxiliary frequency source Y

When the multi-function input terminal function 18 (frequency switching) is invalid, the main frequency X is used as the target frequency.

When the multi-function input terminal function 18 (frequency source switching) is valid, the auxiliary frequency Y is used as the target frequency.

#### 3: Switch between the main frequency source X and the main and auxiliary operation results

When the multi-function input terminal function 18 (frequency switching) is invalid, the main frequency X is used as the target frequency.

When the multi-function input terminal function 18 (frequency switching) is valid, the main and auxiliary operation results are used as the target frequency.

**4: Switch between auxiliary frequency source Y and main and auxiliary operation results**

When the multi-function input terminal function 18 (frequency switching) is invalid, the auxiliary frequency Y is used as the target frequency.

When the multi-function input terminal function 18 (frequency switching) is valid, the main and auxiliary operation results are used as the target frequency.

**Tens place: Frequency source main and auxiliary operation relationship: 0: Main frequency source X+Auxiliary frequency source Y**

The sum of the main frequency X and the auxiliary frequency Y is used as the target frequency. Realize the frequency superposition given function.

**1: Main frequency source X-Auxiliary frequency source Y**

The main frequency X minus the auxiliary frequency Y is the target frequency.

**2: MAX (main frequency source X, auxiliary frequency source Y)**

Take the maximum absolute value of the main frequency X and the auxiliary frequency Y as the target frequency.

**3: MIN (main frequency source X, auxiliary frequency source Y)**

Take the smallest absolute value of the main frequency X and the auxiliary frequency Y as the target frequency.

Function code	Name	Description (setting range)	Factory Default	Change
P0-11	Preset frequency	0.00Hz~Maximum frequency P0-14	50.00Hz	☆

When the main frequency source is selected as "digital setting" or "terminal UP/DOWN", the function code value is the preset frequency of the frequency setting of the inverter.

Function code	Name	Description (setting range)	Factory Default	Change
P0-13	Motor running direction selection	0~2	0	☆

**0: The direction is the same, which is the same as the current running direction of the motor**

**1: Opposite direction, opposite to the current motor running direction ;**

**2: Reverse rotation is prohibited, when there is a reverse rotation command, the inverter will decelerate to 0Hz and enter the stop state ;**

By changing this function code, the rotation direction of the motor can be changed without changing any other parameters, which is equivalent to the conversion of the rotation direction of the motor by adjusting any two lines of the motor (U, V, W). For details.

Tip: After the parameters are initialized, the running direction of the motor will return to the original state. Use with caution in situations where it is strictly forbidden to change the direction of the motor after the system is debugged.

Function code	Name	Description (setting range)	Factory Default	Change
P0-14	Maximum output frequency	50.00Hz~600.00Hz<1>	50.00Hz	★

<1> is the range of frequency decimal point P0-20=2, when P0-20=1, the range is: 50.0Hz~ 1200.0Hz.

Function code	Name	Description (setting range)	Factory Default	Change
P0-15	Upper limit frequency source	0~4	0	★

This function code is used to define the source of the upper limit frequency.

#### 0: Digital setting P0-16

**1: AI1, 100% of the input setting corresponds to P0-14**

**2: AI2, 100% of the input setting corresponds to P0-14**

**3: Communication setting, the upper computer is given by the communication method**

(refer to Appendix A KD600 MODBUS Communication Protocol for details)

**4: PULSE pulse setting, the pulse given ramp can be set by P5-30~P5-34**

In order to avoid the "speeding" of material disconnection, the upper limit frequency can be set by analog quantity. When the inverter runs to the upper limit frequency value, the torque control is invalid, and the inverter continues to run at the upper limit frequency.

Function code	Name	Description (setting range)	Factory Default	Change
P0-16	Upper limit frequency	P0-18~P0-14	50.00Hz	☆
P0-17	Upper limit frequency offset	0.00Hz~P0-14	0.00Hz	☆

When the upper limit frequency is given by analog or Pulse, this parameter is used as the offset of the analog. The function is to add the bias frequency to the set value of the analog upper limit frequency as the set value of the final upper limit frequency.

Function code	Name	Description (setting range)	Factory Default	Change
P0-18	lower frequency	0.00Hz~P0-16	0.00Hz	☆

When the inverter starts to run, it starts from the starting frequency. If the given frequency is lower than the lower limit frequency during the running process, the inverter will always run at the lower limit frequency until the inverter stops or the given frequency is greater than the lower limit frequency.

Function code	Name	Description (setting range)	Factory Default	Change
P0-19	Command source binding selection	000~888	000	☆

Define the binding combination between 3 running command channels and 9 given frequency channels to facilitate switching of frequency sources.

**0: no binding**

**1: Digital setting frequency**

**2: Ai1**

**3: Ai2**

**4: Multi-speed**

**5: Simple PLC**

**6: PID**

**7: Communication given**

**8: PULSE pulse setting (HDI)**

**Units digit: selection of frequency source bound by operation panel command**

**Tens place: Terminal command binding frequency source selection**

**Hundreds place: Communication command binding frequency source selection**

**Thousands: reserved**

The meaning of the above frequency given channel is the same as the main frequency X selection P0-06, please refer to the description of the function code of P0-06.

Different running command channels can be bundled with the same frequency given channel. When the command source has a bundled frequency source, the frequency source set by P0-06~P0-10 will no longer work when the command source is valid.

Function code	Name	Description (setting range)	Factory Default	Change
P0-20	Frequency Decimal Selection	1~2	2	★

This parameter is used to determine the resolution of all frequency-related function codes.

**1: 1 decimal point;**

**2: 2 decimal places.**

Function code	Name	Description (setting range)	Factory Default	Change
P0-21	Acceleration and deceleration time unit	0~2	1	★

In order to meet the needs of various fields, KD600 provides 3 kinds of acceleration and deceleration time units, namely 1 second, 0.1 second and 0.01 second.

**0:1 second**

**1:0.1 second**

**2: 0.01 seconds**

**Note:** When modifying this function parameter, the number of decimal points displayed by the 4 groups of acceleration and deceleration time will change, and the corresponding acceleration and deceleration time will also change. Special attention should be paid during the application process.

Function code	Name	Description (setting range)	Factory Default	Change
P0-22	Acceleration and deceleration time reference frequency	0~2	0	★

This parameter is used to define the reference frequency of acceleration and deceleration time, and its meaning is shown in Figure 5-2:

**0: maximum frequency (P0-14);**

**1: Preset frequency (P0-11);**

**2: Motor rated frequency (P4-05 or A1-05).**

Function code	Name	Description (setting range)	Factory Default	Change
P0-23	Acceleration time 1	0.0s~3000.0s<1>	10.0s	☆
P0-24	Deceleration time 1	0.0s~3000.0s<1>	10.0s	☆

<1> is the range of acceleration/deceleration time unit P0-21=1, when P0-21=0: 0s~3000.0s; when P0-21=2: 0.00s~300.00s;

Acceleration time refers to the time required for the inverter to accelerate from zero frequency to the reference frequency of acceleration and deceleration (determined by P0-22), see  $t_1$  in Figure 5-2.

Deceleration time refers to the time required for the inverter to decelerate from the reference frequency of acceleration and deceleration (determined by P0-22) to the zero frequency, as shown in  $t_2$  in Figure 5-2.

KD600 provides 4 groups of acceleration and deceleration time, users can use the digital input terminal DI to switch and select, and the four groups of acceleration and deceleration time can be set by the following function codes:

Group 1: P0-23, P0-24;      Group 2: P7-03, P7-04;  
Group 3: P7-05, P7-06;      Group 4: P7-07, P7-08.

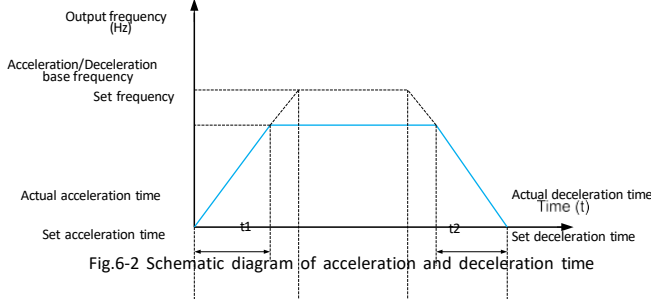

Function code	Name	Description (setting range)	Factory Default	Change
P0-25	Overmodulation voltage boost value	0%~10%	3%	★

This parameter is used to improve the output voltage capability of the inverter in the constant power area, and the rated voltage of the motor is 100%. The larger the value, the higher the voltage boosting ability, but the larger the current ripple content, so attention should be paid during use. Usually no modification is required.

Function code	Name	Description (setting range)	Factory Default	Change
P0-26	Carrier frequency	0.5kHz~16.0kHz	Model is determined	☆

This function adjusts the carrier frequency of the inverter. By adjusting the carrier frequency, the motor noise can be reduced, the resonance point of the mechanical system can be avoided, the line-to-ground leakage current can be reduced, and the interference generated by the inverter can be reduced.

When the carrier frequency is low, the higher harmonic components of the output current increase, the loss of the motor increases, and the temperature rise of the motor increases.

When the carrier frequency is high, the motor loss decreases and the motor temperature rise decreases, but the inverter loss increases, the inverter temperature rise increases, and the interference increases.

Adjusting the carrier frequency affects the following performance:

Motor noise	Leakage current
Carrier frequency	Low → High
Motor noise	Big → Small
Output current waveform	Bad → Good
Motor temperature rise	High → Low
Inverter temperature rise	Low → High
Leakage current	Small → Large
External Radiation Interference	Small → Large

The factory setting of carrier frequency is different for inverters of different power. Although the user can modify it according to the needs, it should be noted that if the carrier frequency is set higher than the factory value, the temperature rise of the inverter radiator will increase. At this time, the user needs to derate the inverter, otherwise the inverter will be in danger of overheating alarm.

Inverter power	Carrier frequency range	Factory default carrier frequency
0.75kW~5.5kW	0.5kHz~16.0kHz	6.0kHz
7.5kW~75kW	0.5kHz~16.0kHz	4.0kHz
90kW~450kW	0.5kHz~16.0kHz	2.0kHz

Function code	Name	Description (setting range)	Factory Default	Change
P0-27	The carrier frequency is adjusted with temperature	0~1	1	☆

**0: invalid**

**1: Valid**

The inverter can automatically adjust the carrier frequency according to its own temperature, which can reduce the possibility of the inverter overheating alarm.

Function code	Name	Description (setting range)	Factory Default	Change
P0-28	Parameter initialization	0~4	0	☆

0: No operation;

1: Restore factory parameters, excluding motor parameters, record information and P0-20

2: Clear record information, including fault record U0 group, accumulated power-on time P7- 33, accumulated running time P7-34 and power consumption P7-72;

3: Backup current user parameters; 4:

Restore user backup parameters.

Function code	Name	Description (setting range)	Factory Default	Change
P0-29	LCD upload and download parameter selection	0~4	0	☆

Download means that the inverter stores the function code parameter value to the LCD.

Upload means that the LCD writes the stored inverter parameter values into the inverter, so the LCD needs to download the parameters before uploading the parameters.

**0: No function;**

**1: Download parameters to LCD;**

**2: Only upload P4 group parameters;**

**3: Upload parameters other than group P4;**

**4: Upload all parameters.**

**Group P1: Start-stop control**

Function code	Name	Description (setting range)	Factory Default	Change
P1-00	Start method	0~2	0	☆

**0: Direct start**

When the start DC braking time is not set to 0, the DC braking is performed first before starting. It is suitable for occasions where small inertia loads may reverse during startup.

**1: Restart after speed tracking**

The inverter first judges the speed and direction of the motor, and then starts at the frequency corresponding to the tracked motor speed, and implements a smooth and shock-free start for the rotating motor, which is suitable for instantaneous power failure of large inertial loads. start up.

**2: The asynchronous motor is pre-excited to start**

Which is used to establish a magnetic field before the operation of the asynchronous motor to reduce the current impact during rapid start.

Function code	Name	Description (setting range)	Factory Default	Change
P1-01	Speed tracking method	1~2	0	★

In order to complete the speed tracking process in the shortest time, select the way that the inverter tracks the motor speed:

0: Track down from the frequency at the time of power failure, this method is usually selected;

1: Start tracking from the target frequency, and use it when the power failure time is longer and restart;

2: Start tracking from the current speed, generally used for power generation loads.

Function code	Name	Description (setting range)	Factory Default	Change
P1-02	Maximum speed tracking current	30%~150%	100%	★
P1-03	Speed tracking speed	1~100	20	☆

In the speed tracking restart mode, select the current and speed of the speed tracking. The larger the parameter, the faster the tracking speed. But too large may cause unreliable tracking.

Function code	Name	Description (setting range)	Factory Default	Change
P1-04	Start frequency	0.00Hz~10.00Hz	0.00Hz	☆
P1-05	Start frequency hold time	0.0s~100.0s	0.0s	★
P1-06	Start DC braking current	0%~100%	0%	★
P1-07	Start DC braking time	0.0s~100.0s	0.0s	★

Start DC braking is generally used to stop the motor first and then start it.

If the start mode is direct start, the inverter will first perform DC braking according to the set starting DC braking current when starting, and then start running after the set starting DC braking time. The greater the DC braking current, the greater the braking force.

The starting DC braking current refers to the percentage relative to the rated current of the inverter.

Function code	Name	Description (setting range)	Factory Default	Change
P1-08	Selection of acceleration and deceleration frequency curve mode	0~2	0	★

**0: Linear acceleration and deceleration;**

**1: S curve acceleration and deceleration A;**

**2: S curve acceleration and deceleration B.**

Function code	Name	Description (setting range)	Factory Default	Change
P1-09	S-curve acceleration start time	0.0%~100.0%	20.0%	★
P1-10	S-curve acceleration end time	0.0%~100.0%	20.0%	★
P1-11	S-curve deceleration start time	0.0%~100.0%	20.0%	★
P1-12	S-curve deceleration end time	0.0%~100.0%	20.0%	★

The above parameters can be used to set the slow start without impact when the drive starts to accelerate, and the acceleration and deceleration curves are adjusted to different degrees of S acceleration and deceleration curves by the set value. Start S-curve acceleration and deceleration, the drive will make acceleration and deceleration curves at different rates according to the original acceleration and deceleration time.

**Note:** Acceleration and deceleration time = 0, the S curve function is invalid.

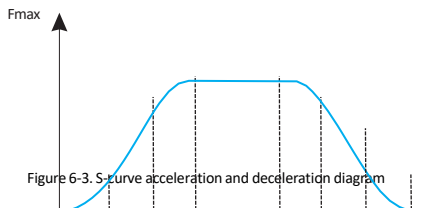

Figure 6-3. S-curve acceleration and deceleration diagram

Function code	Name	Description (setting range)	Factory Default	Change
P1-13	Stop mode	0~1	0	☆

0: Decelerate to stop, after the stop command is valid, the inverter reduces the output frequency according to the deceleration mode and the defined acceleration and deceleration time, and stops after the frequency drops to 0.

1: Coast to stop, after the stop command is valid, the inverter immediately stops output. The load coasts to a stop according to the mechanical inertia.

Function code	Name	Description (setting range)	Factory Default	Change
P1-14	DC braking start frequency at stop	0.00Hz~P0-14	0.00Hz	☆

In the process of deceleration and stop, when this frequency is reached, the DC braking process of stop starts. Setting this value too large may cause overvoltage.

Function code	Name	Description (setting range)	Factory Default	Change
P1-15	DC braking waiting time at stop	0.0s~100.0s	0.0s	☆

After the running frequency is reduced to the starting frequency of DC braking at stop, the inverter stops outputting for a period of time, and then starts the DC braking process. It is used to prevent faults such as overcurrent that may be caused by starting DC braking at higher speeds.

Function code	Name	Description (setting range)	Factory Default	Change
P1-16	Stop braking DC current	0%~100%	0%	☆

This parameter is used to set the percentage of DC braking current, and the rated current of the inverter is 100%. The larger the braking current is, the more obvious the braking effect is, but when the braking current is too large, the braking time P1-17 should not be set too large.

Function code	Name	Description (setting range)	Factory Default	Change
P1-17	Stop braking DC current	0%~100%	0%	☆

This parameter is used to set the DC braking holding time. When it is 0, there is no DC braking process.

Function code	Name	Description (setting range)	Factory Default	Change
P1-21	Demagnetization time	0.01s~3.00s	0.50s	★

This parameter is used to set the waiting time of the inverter from coasting to restart, so as to reduce the influence of motor residual magnetism on startup.

Function code	Name	Description (setting range)	Factory Default	Change
P1-23	Instantaneous stop and non-stop mode selection	0~2	0	★

This parameter is used to set the method to prevent the shutdown due to the bus voltage undervoltage caused by the grid voltage drop, and is often used in fan and other occasions.

0: Invalid, it will still run at the given frequency when the grid voltage is momentarily cut off. At this time, an undervoltage fault may occur and the machine will shut down;

1: Automatically adjust the deceleration rate, and automatically adjust the deceleration rate when the grid voltage is momentarily cut off to keep the inverter running. After the grid voltage recovers, it will automatically accelerate to the target frequency. If the power grid is out of power for a long time, there will still be an undervoltage fault and shutdown;

2: Decelerate to stop. In case of instantaneous power failure or sudden voltage drop, the inverter will decelerate and stop according to P1-24. If you need to start again after stopping, you need to give the start signal again.

## Chapter 6 Description of Function Codes

Function code	Name	Description (setting range)	Factory Default	Change
P1-24	The deceleration time of the momentary stop and non-stop deceleration stop	0.0s~100.0s	10.0s	★
P1-25	Instantaneous power failure and non-stop effective voltage	60%~85%	80%	★

This parameter is used to judge whether the grid voltage is the threshold for instantaneous power failure. When the bus voltage is less than P1-25, the inverter will decelerate according to the method set by P1-23 to maintain the bus voltage constant. 100% corresponds to the voltage level of the inverter.

Function code	Name	Description (setting range)	Factory Default	Change
P1-26	Instantaneous power failure and non-stop recovery of voltage	85%~100%	90%	★

This parameter is used to judge whether the grid voltage returns to the normal threshold. When the bus voltage is greater than P1-26, the inverter will no longer decelerate. When the duration is greater than P1-27, the inverter will accelerate until it reaches the set frequency. 100% corresponds to the voltage level of the inverter.

Function code	Name	Description (setting range)	Factory Default	Change
P1-27	Instantaneous power failure and non-stop recovery voltage judgment	0.0s~300.0s	0.3s	★

This parameter is used for the time judgment of grid voltage recovery. When the grid voltage is higher than P1-26, the timing starts, otherwise it is cleared to 0.

Function code	Name	Description (setting range)	Factory Default	Change
P1-28	Instantaneous stop and non-stop automatic gain adjustment	0~100	40	☆
	Instantaneous stop and non-stop automatic adjustment of integral	1~100	20	☆

It takes effect only when P1-23=1 is selected for the instantaneous stop and non-stop mode. It is used to adjust the deceleration speed and generally does not need to be modified.

## Group P2: V/F control parameters

This group of function codes is only valid for V/F control (P0-03=2), and invalid for vector control.

V/F control is suitable for general loads such as fans and water pumps, or applications where one inverter has multiple motors, or where the power of the inverter is one level smaller than that of the motor or more than two levels larger.

Function code	Name	Description (setting range)	Factory Default	Change
P2-00	V/F curve setting	0~7	0	★

For fan and water pump loads, square V/F control can be selected: 0:

Straight line V/F curve. Suitable for ordinary constant torque loads;

1: Multi-point V/F curve. Suitable for special loads such as dehydrators and centrifuges; 2: Square V/F curve. Suitable for centrifugal loads such as fans and pumps;

3 to 5: Corresponding to the 1.7th, 1.5th and 1.3rd degree V/F curves, which are between the straight line and the square curve.

6: VP fully separated mode. At this time, the output frequency and output voltage of the inverter are independent of each other, the output frequency is determined by the frequency source, and the output voltage is determined by P2-15 (VP separation voltage source).

VP complete separation mode is generally used in induction heating, inverter power supply, torque motor control and other occasions.

7: VP semi-separation mode.

In this case, V and P are proportional, but the proportional relationship can be set by the voltage source P2-15, and the relationship between V and P is also related to the rated voltage and rated frequency of the motor in group P1.

Assuming that the voltage source input is X (X is a value between 0 and 100%), the relationship between the output voltage V of the inverter and the frequency P is:

$$V/F=2 * X * (\text{motor rated voltage})/(\text{motor rated frequency})$$

Function code	Name	Description (setting range)	Factory Default	Change
P2-01	Torque boost	0.0%~30.0%	0.0%	☆
P2-02	Torque boost cut-off frequency	0.00Hz~Maximum frequency	25.00Hz	★

## Chapter 6 Description of Function Codes

In order to compensate the low frequency torque characteristic of V/F control, some boost compensation is made to the output voltage of the inverter at low frequency.

If the torque boost setting is too large, the motor is easily overheated, and the inverter is prone to overcurrent. Generally, the torque boost should not exceed 8.0%.

Effective adjustment of this parameter can effectively avoid overcurrent during startup. For larger loads, it is recommended to increase this parameter, and when the load is light, this parameter setting can be reduced. When the torque boost is set to 0.0, the inverter is automatic torque boost.

Torque boost torque cut-off frequency: Below this frequency, the torque boost torque is valid, and if it exceeds this set frequency, the torque boost becomes invalid. See Figure 5-4 for details.

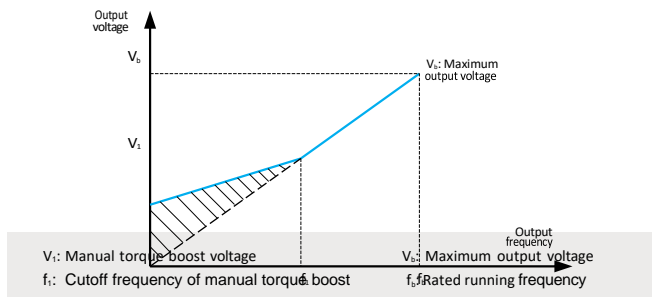

Fig.6-4 Manual torque boost

Function code	Name	Description (setting range)	Factory Default	Change
P2-03	V/F frequency point P1	0.00Hz~P2-05	1.30Hz	★
P2-04	V/F voltage point V1	0.0%~100.0%	5.2%	★
P2-05	V/F frequency point P2	P2-03~P2-07	2.50Hz	★
P2-06	V/F voltage point V2	0.0%~100.0%	8.8%	★
P2-07	V/F frequency point P3	P2-05~ Motor rated frequency	15.00Hz	★
P2-08	V/F voltage point V3	0.0%~100.0%	35.0%	★

These six parameters are used to define the multi-point V/F curve.

The multi-point V/F curve is set based on the motor's load characteristic. The relationship between voltages and frequencies is:

$$V_1 < V_2 < V_3, \quad P_1 < P_2 < P_3$$

At low frequency, higher voltage may cause overheat or even burnt out of the motor and over-current stall or overcurrent protection of the AC drive.

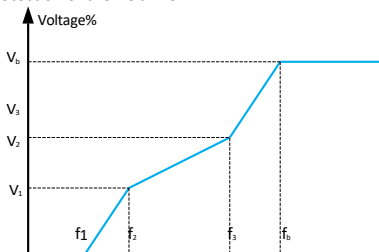

$V_1$ - $V_3$ : The percentage of the voltage of the 1st-3rd stage of the multi-speed V/F

$f_1$ - $f_3$ : Frequency percentage of 1st-3rd stage of multi-speed V/F

$V_c$ : Rated motor voltage

$f_c$ : Rated motor running frequency

Fig.6-5 V/F curve setting diagram

Function code	Name	Description (setting range)	Factory Default	Change
P2-09	Slip Compensation Coefficient	0.0%~200.0%	50.0%	☆

Setting this parameter can compensate the slip generated by the load during V/F control, and reduce the variation of the motor speed with the load during V/F control. Generally, 100.0% corresponds to the rated slip of the motor with rated load.

When the speed of the motor with load is lower than the given speed, this value can be appropriately increased, and vice versa. Usually no adjustment is required.

Function code	Name	Description (setting range)	Factory Default	Change
P2-10	Flux Brake Gain	0~200	100	☆

This parameter can suppress the bus voltage rise during the deceleration process of the inverter. The larger the value, the better the suppression effect.

The magnetic flux braking is to increase the motor terminal current by increasing the output voltage of the inverter, thereby improving the consumption capacity of the feedback energy and suppressing the rise of the bus voltage. The greater the gain, the greater the motor current, so please pay attention in the application. It is recommended to set this value to 0 when there is a braking resistor at the same time, otherwise an abnormality may occur due to the large deceleration current during deceleration.

Function code	Name	Description (setting range)	Factory Default	Change
P2-11	Oscillation suppression gain	0~100	Model is determined	☆

This parameter is used to suppress motor vibration. When the motor oscillates, please increase the value appropriately, but try to set it as small as possible when the motor does not oscillate, so as not to have too much influence on the V/F operation. Under normal circumstances, no modification is required.

Function code	Name	Description (setting range)	Factory Default	Change
P2-13	VF slip compensation time constant	0.02s~1.00s	0.30s	☆

This parameter is used to set the slip compensation time constant. Decreasing this value can enhance the response speed, but the speed fluctuation may increase. Increasing this value increases speed stability, but reduces responsiveness. Under normal circumstances, no modification is required.

Function code	Name	Description (setting range)	Factory Default	Change
P2-15	Output voltage source selection when VF is separated	0~7	0	☆

#### 0: Digital setting (P2-14);

1: AI1;

2: AI2;

**3: Multi-segment instruction;**

**4: Simple PLC;**

**5: PID;**

**6: Communication given;**

**7: PULSE pulse setting (Di5);**

**100.0% corresponds to the rated voltage of the motor.**

Function code	Name	Description (setting range)	Factory Default	Change
P2-16	V/F separation output voltage digital setting	0V~Motor rated voltage	0V	☆

This parameter is used to set the voltage output value when the V/F separation voltage is set and the voltage source is the digital setting value.

Function code	Name	Description (setting range)	Factory Default	Change
P2-17	V/F separation output voltage acceleration time	0.0~3000.0s	1.0s	☆

This parameter is used to set the acceleration time of voltage output from 0 to rated voltage when V/F is separated.

Function code	Name	Description (setting range)	Factory Default	Change
P2-18	V/F separation output voltage deceleration time	0.0~3000.0s	1.0s	☆

This parameter is used to set the deceleration time of voltage output from rated voltage to 0 when V/F is separated.

Function code	Name	Description (setting range)	Factory Default	Change
P2-19	V/F separation and stop mode selection	0~1	0	☆

**0: Frequency and output voltage deceleration time are independent ;**

**1: After the voltage is reduced to 0, the frequency is reduced again.**

## Group P3: Vector control parameters

The P2 group function code is only valid for vector control, that is, P0-03=1 is valid, and P0-03=2 is invalid.

Function code	Name	Description (setting range)	Factory Default	Change
P3-00	Switching frequency P1	0.00~P3-02	5.00 Hz	☆
P3-02	Switching frequency P2	P3-00~P0-14	10.00 Hz	☆
P3-04	Low frequency speed proportional gain	0.1~10.0	4.0	☆
P3-05	Low frequency speed integration time	0.01s~10.00s	0.50s	☆
P3-06	High frequency speed proportional gain	0.1~10.0	2.0	☆

P3-00 switching frequency 1 and P3-02 switching frequency 2, P3-04/P3-05, P3-06/P3-07 are the PI regulator parameters at low speed and high speed respectively, and the switching relationship is shown in Figure 5-6. By setting the proportional coefficient and integral time of the speed regulator, the speed dynamic response characteristics of the vector control can be adjusted. Increasing the proportional gain and decreasing the integral time can speed up the dynamic response of the speed loop. If the proportional gain is too large or the integral time is too small, the system may oscillate.

### Suggested adjustment method:

If the factory parameters can not meet the requirements, fine-tune on the basis of the factory default parameters, first increase the proportional gain to ensure that the system does not oscillate; then reduce the integral time, so that the system has faster response characteristics and less overshoot.

Note: If the PI parameter is not set properly, it may cause the speed overshoot to be too large, and even cause an overvoltage fault when the overshoot falls back.

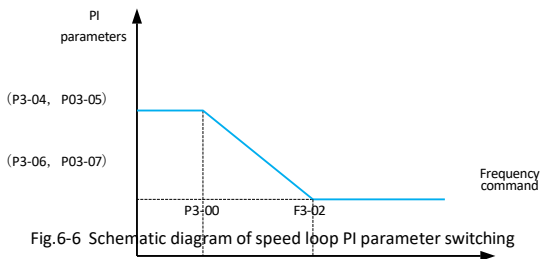

Fig.6-6 Schematic diagram of speed loop PI parameter switching

Function code	Name	Description (setting range)	Factory Default	Change
P3-08	Speed loop integral attribute selection	0~1	0	★

0: The integral takes effect during the acceleration and deceleration process, and the response is fast in the case of rapid acceleration, but it may cause speed overshoot;

1: Integral separation during acceleration and deceleration, rapid acceleration can effectively reduce speed overshoot, but the response speed will be slower.

Function code	Name	Description (setting range)	Factory Default	Change
P3-11	Torque current regulator Kp	0~30000	2200	☆
P3-12	Torque current regulator Ki	0~30000	1500	☆
P3-13	Excitation current regulator Kp	0~30000	2200	☆
P3-14	Excitation current regulator Ki	0~30000	1500	☆

The vector control current loop PI adjustment parameter, this parameter will be automatically obtained after the asynchronous machine is completely tuned, and generally does not need to be modified. The integral regulator of the current loop does not use the integral time as the dimension, but directly sets the integral gain. If the current loop PI gain is set too large, it may cause the entire control loop to oscillate. Therefore, when the current oscillation or torque fluctuation is large, the PI proportional gain or integral gain here can be manually reduced.

Function code	Name	Description (setting range)	Factory Default	Change
P3-15	Flux Brake Gain	0~200	0	☆

This parameter can suppress the bus voltage rise during the deceleration process of the inverter. The larger the value, the better the suppression effect.

The magnetic flux braking is to increase the motor terminal current by increasing the output voltage of the inverter, thereby improving the consumption capacity of the feedback energy and suppressing the rise of the bus voltage. The greater the gain, the greater the motor current, so please pay attention in the application. It is recommended to set this value to 0 when there is a braking resistor at the same time, otherwise an abnormality may occur due to the large deceleration current during deceleration.

## Chapter 6 Description of Function Codes

Function code	Name	Description (setting range)	Factory Default	Change
P3-16	Field weakening torque correction factor	50%~200%	100%	☆

This parameter is used to correct the motor torque value in the constant power area, and generally does not need to be modified.

Function code	Name	Description (setting range)	Factory Default	Change
P3-17	Slip compensation gain	50%~200%	100%	☆

This parameter is used to adjust the steady speed accuracy of the motor. When the speed is too high, the parameter should be adjusted to a smaller value, and vice versa.

Function code	Name	Description (setting range)	Factory Default	Change
P3-18	Speed loop feedback filter time constant	0.000~1.000s	0.015s	☆

This parameter is used to set the filter time constant of the speed feedback value. Increasing the value can improve the speed stability, but will reduce the system response speed; decreasing the value can improve the system response speed, but will reduce the speed stability. Usually no modification is required.

Function code	Name	Description (setting range)	Factory Default	Change
P3-19	Speed loop output filter time constant	0.000~1.000s	0.000s	☆

This parameter is used to set the filter time constant of the torque given value, which is beneficial to improve the speed stability. Generally, no setting is required.

Function code	Name	Description (setting range)	Factory Default	Change
P3-20	Electric torque upper limit source	0~4	0	☆

0: P3-21

- 1: AI1, AI linear setting refer to P5-15~P5-19, multi-point curve setting refer to P5-45 and PE group;
- 2: AI2, AI linear setting refer to P5-20~P5-24, multi-point curve setting refer to P5-45 and PE group;
- 3: Communication given, directly written by the host computer through the communication address, 100% corresponding to P3-21, please refer to Appendix A KD600 Modbus communication protocol for details;
- 4: PULSE setting, refer to the setting instructions of function codes P5-30~P5-33. 100% corresponding to P3-21.

Function code	Name	Description (setting range)	Factory Default	Change
P3-21	Electric torque upper limit	0.0%~200.0%	150.0%	☆

This parameter is used to set the upper limit value of the motor torque of the inverter. When the actual direction of the motor is the same as the direction of the torque, it is electric, otherwise it is braking.

When the electric torque and braking torque need different setting values, they can be set separately through P3-21 and P3-23.

For example, in the case of cam load, due to the periodic change of the electric and braking states, at this time, by appropriately reducing the upper limit of the braking torque P3-23, the rise of the inverter bus voltage can be effectively reduced without affecting the normal operation of the driving load.

Function code	Name	Description (setting range)	Factory Default	Change
P3-22	Braking torque upper limit source	0~4	0	☆

0: P3-23;

- 1: AI1, AI linear setting refer to P5-15~P5-19, multi-point curve setting refer to P5-45 and PE group;
- 2: AI2, AI linear setting refer to P5-20~P5-24, multi-point curve setting refer to P5-45 and PE group;
- 3: Communication given, directly written by the host computer through the communication address, 100% corresponding to P3-21, please refer to Appendix A KD600 Modbus communication protocol for details;

## Chapter 6 Description of Function Codes

---

4: PULSE setting, refer to the setting instructions of function codes P5-30~P5-33; 100% corresponding to P3-23.

Function code	Name	Description (setting range)	Factory Default	Change
P3-23	Braking torque upper limit	0.0~200.0%	150.0%	☆

This parameter is used to set the upper limit of braking torque of the inverter. This parameter is used to set the upper limit value of the motor torque of the inverter. When the actual direction of the motor is the same as the direction of the torque, it is electric, otherwise it is braking.

When the electric torque and braking torque need different setting values, they can be set separately through P3-21 and P3-23.

For example, in the case of cam load, due to the periodic change of the electric and braking states, at this time, by appropriately reducing the upper limit of the braking torque P3-23, the rise of the inverter bus voltage can be effectively reduced without affecting the normal operation of the driving load.

## Group P4: First motor parameter

Function code	Name	Description (setting range)	Factory Default	Change
P4-00	Motor parameter tuning	0~2	0	☆

**Tip:** Before tuning, you must set the correct motor rated parameters (P4-01~P4-06). 0: No operation, that is, tuning is prohibited.

1: Static tuning, suitable for occasions where the motor and the load are not easily disconnected and cannot be rotated for tuning.

Action description: Set the function code to 1 and press the RUN key to confirm, the inverter will perform static tuning.

2: Rotary tuning

In order to ensure the dynamic control performance of the inverter, please select rotary tuning. During rotary tuning, the motor must be disconnected from the load (no load).

After selecting rotary tuning, the inverter will perform static tuning first. After the static tuning is completed, the motor will follow the acceleration set by P4-12.

Accelerate to 80% of the rated frequency of the motor, keep it for a period of time, and then decelerate to zero speed according to the deceleration set by P4-13, and the rotation tuning is over.

Action description: Set the function code to 2, and press the RUN key to confirm, the inverter will perform rotary tuning.

Tuning operation instructions:

When P4-00 is set to 1 or 2 and then press the ENTER key, "TUNE" will be displayed and flashing at this time, then press the RUN key to start parameter tuning, and the displayed "TUNE" will stop flashing. When the tuning is completed, the display returns to the stop state interface. During the tuning process, you can press the STOP key to abort the tuning.

When the tuning is completed, the value of P4-00 automatically returns to 0.

Function code	Name	Description (setting range)	Factory Default	Change
P4-01	Motor 1 rated power	0.1kw~1000.0kw	Model is determined	★
P4-02	Motor 1 rated voltage	1V~1500V	380V	★
P4-03	Motor 1 Number of motor poles	2 to 64	Model is determined	○
P4-04	Motor 1 rated current	0.1A~6000.0A<1>	P4-01 OK	★

## Chapter 6 Description of Function Codes

Function code	Name	Description (setting range)	Factory Default	Change
P4-05	Motor 1 rated frequency	0.01Hz~P0-14	50.00 Hz	★
P4-06	Motor 1 rated speed	0rpm~60000rpm	P4-01 OK	★

<1> When the rated power of the motor P4-01≤30KW, P4-4 is 2 decimal points, and when P4-01>30KW, it is 1 decimal point.

The above function codes are the parameters on the motor nameplate. Whether V/F or vector control is used, the relevant parameters need to be set accurately according to the motor nameplate.

In order to obtain better V/F or vector control performance, motor parameter tuning is required, and the accuracy of the tuning result is closely related to the correct setting of the motor nameplate parameters.

Function code	Name	Description (setting range)	Factory Default	Change
P4-07	Motor 1 no-load current	0.01A~P4-04<1>	Model is determined	★
P4-08	Motor 1 stator resistance	0.001Ω~65.535Ω	Model is determined	★
P4-09	Motor 1 rotor resistance	0.001Ω~65.535Ω	Model is determined	★
P4-10	Motor 1 mutual inductance	0.1Mh~6553.5Mh	Model is determined	★
P4-11	Motor 1 leakage inductance	0.01Mh~655.35Mh	Model is determined	★

<1> When the rated power of the motor P4-01>30KW, P4-4 is 1 decimal point, and when P4-01≤30KW, it is 2 decimal points

<2>When the rated power of the motor P4-01>30KW, add 1 decimal point, and when P4-01≤30KW, the decimal point is shown in the table

P4-07~P4-11 function code parameters are generally not on the motor nameplate and need to be obtained through inverter tuning. Among them, "static tuning" can only obtain three parameters of P4-07~P4-09, and "rotary tuning" can obtain all 5 parameters. value of a function code.

### Note:

After modifying P4-01, the values of motor parameters P4-02~P4-11 will change accordingly.

Function code	Name	Description (setting range)	Factory Default	Change
P4-12	Acceleration at Dynamic Full Tuning	1.0s~6000.0s	10.0s	☆
P4-13	Deceleration at dynamic full tuning	1.0s~6000.0s	10.0s	☆

The above function code is the acceleration and deceleration time when the motor is fully tuned, and the user can reasonably set this parameter according to the actual situation of the motor.

Function code	Name	Description (setting range)	Factory Default	Change
P4-17	Synchronous motor stator resistance	0.001Ω~65.535Ω	Model is determined	★
P4-18	Synchronous motor D-axis inductance	0.01Mh~655.35Mh	Model is determined	★
P4-19	Synchronous motor Q-axis inductance	0.01Mh~655.35Mh	Model is determined	★
P4-20	Synchronous motor back EMF	1V~65535V	Model is determined	★
P4-21	No-load current of synchronous motor	0.0%~50.0%	10.0%	★

## Group P5: Vector control parameters

KD600 series inverters come standard with 7 multi-function digital input terminals (among which HDI can be used as high-speed pulse input terminal) and 2 analog input terminals.

Function code	Name	Description (setting range)	Factory Default	Change
P5-00	DI1 terminal function	0~53	1	★
P5-01	DI2 terminal function	0~53	2	★
P5-02	DI3 terminal function	0~53	9	★
P5-03	DI4 terminal function	0~53	12	★
P5-04	DI5 terminal function	0~53	13	★
P5-05	DI6 terminal function	0~53	0	★
P5-06	DI7 terminal function	0~53	0	★

This parameter is used to set the function corresponding to the digital multi-function input terminal. The specific function is shown in the attached table 6-1.

Table 6-1 DI terminal function description

Value	Function	Description
0	No function	Set 0 for reserved terminals to avoid malfunction.
1	Forward RUN (FWD)	The terminal is used to control forward or reverse RUN of the AC drive.
2	Reverse RUN (REV)	
3	3-wire operation control	The terminal determines three-line control of the AC drive. For details, see the description of F06.13.
4	Forward jog	Forward jog indicates forward JOG running, while reverse jog indicates reverse JOG running. The JOG frequency, acceleration time and deceleration time are described respectively in F09.06, F09.07 and F09.08.
5	Reverse jog	
6	Terminal UP	When this function takes effect, the frequency increasing command and decreasing command will be modified when the frequency is given by the external terminal. When the frequency source is set to digital setting, the set frequency can be adjusted up and down. Up/Down change rate is set by P5-12
7	Terminal DOWN	

Value	Function	Description
8	Free parking	The inverter blocks the output, and the motor stopping process not controlled by the inverter. It is often used when there is a large inertia load and there is no requirement for stopping time.
9	Fault reset (RESET)	External fault reset function. Same function as the RESET key on the keyboard.
10	Run pause	The inverter decelerates to stop, but all running parameters are in the memory state. Such as PLC parameters, swing frequency parameters, PID parameters. After this signal disappears, the inverter resumes running to the state before stopping.
11	External fault normally open input	When the external fault signal is sent to the inverter, the inverter reports a fault and stops.
12	Multi-speed terminal 1	A total of 16-segment settings can be achieved through the digital state combination of the four terminals. The detailed combination is shown in Table 5-2.
13	Multi-speed terminal 2	
14	Multi-speed terminal 3	
15	Multi-speed terminal 4	
16	Acc/ Dec time selection 1	Four kinds of acceleration and deceleration time settings can be selected through the combination of the digital states of the two terminals. The detailed combination is shown in Table 5-3.
17	Acc/ Dec time selection 2	
18	Frequency source switchover	The main frequency source X and the switching frequency source set by P0-10 are switched through this terminal.
19	UP/DOWN setting clear (terminal, keyboard)	Use this terminal to clear the frequency value changed by UP/DOWN and restore the given frequency to the value set by P0-11.
20	Run command switchover terminal	When the command source is not the keyboard, the terminal control and keyboard control can be switched through this terminal. When it is communication, communication and keyboard control can be carried out through this terminal.
21	Acceleration/Deceleration prohibited	Ensure that the inverter is not affected by external signals (except stop command) and maintain the current output frequency.

## Chapter 6 Description of Function Codes

Value	Function	Description
22	PID invalidation (pause)	When the frequency source P0-06 is PID, the PID failure will make the inverter maintain the current frequency output.
23	PLC status reset	The PLC is suspended during the execution process, and can be restored to the initial state of the simple PLC through this terminal being valid when it is running again.
24	Swing pause	Pause the swing frequency, and the inverter outputs at the center frequency.
25	Timer trigger input	Timer input signal, when the valid time of this signal reaches the set closing and opening time, the timing output function is valid. It needs to be used with Y1 output No. 17 function and P7-39, P7-40.
26	Immediate DC braking	When this terminal is valid, the inverter will DC brake immediately, and the braking current P1-16 will be set
27	External fault normally closed input	When the external fault signal is sent to the inverter, the inverter will report Err28 fault and stop according to the stop mode set by P9-23.
28	Counter input	The terminal of counting pulse input, cooperate with Pb-08 to realize the function of setting count value
29	Counter reset	This terminal is used to clear the counter status.
30	Length count input	This terminal is used to count the length.
31	Length reset	This terminal is used to clear the length.
32	Torque control prohibited	The AC drive is prohibited from torque control and enters the speed control mode.
33	Pulse input (enabled only for HDI)	It is the pulse input terminal (only valid for HDI)
34	Frequency modification prohibited	When the terminal is active, the inverter does not respond to frequency changes.
35	PID action direction is reversed	When this terminal is valid, the PID action direction is opposite to the direction set by PA-04.
36	External STOP terminal 1	When the command source P0-04 is the operation panel, this terminal can be used to stop the inverter, which is equivalent to the function of the STOP key on the keyboard.

Value	Function	Description
37	Control command switching terminal 2	Used to switch between terminal control and communication control.
38	PID integral pause	This terminal is valid, the PID integral adjustment is suspended, but the PID proportional adjustment and differential adjustment functions are still valid.
39	Frequency source X and preset frequency switching terminal	If this terminal is valid, the frequency source X is replaced by the preset frequency (P0-11).
40	Frequency source Y and preset frequency switching terminal	If this terminal is valid, the frequency source Y will be replaced by the preset frequency (P0-11).
41	Switch between motor 1 and motor 2	Realize the switching of two sets of motor parameters of motor 1 and motor 2
42	Reserved	reserved
43	PID parameter switchover	When this terminal is invalid, the first group of PID parameters is used, and when it is valid, the second group of PID parameters is used, see the description of PA group for details.
44	Speed control/torque control switching	Switches the drive between torque control and speed control modes. When this terminal is invalid, the inverter runs in the mode defined by Pd-10 (speed/torque control mode), and when this terminal is valid, it switches to another mode.
45	Emergency pull over	When this terminal is valid, the inverter stops at the fastest speed, and the current is at the set current upper limit during the stop process. This function is used to meet the requirement that the inverter needs to stop as soon as possible when the system is in an emergency state.
46	External parking terminal 2	In any control mode (panel control, terminal control, communication control), this terminal can be used to decelerate the inverter to stop, and the deceleration time is fixed at deceleration time 2 (P7-04).
47	Deceleration DC braking	When this terminal is valid, the inverter first decelerates to the starting frequency of DC braking at stop, and then switches to DC braking state.

Value	Function	Description
48	The running time is cleared	When this terminal is valid, the timing time of the current running of the inverter will be cleared. This function needs to be used in conjunction with the timing running (P7-36) and the current running time setting value (P7-38).
49	Two-wire/three-wire switching	Used to switch between two-wire control mode and three-wire mode.
50	Inversion prohibited	This terminal is valid, and the inverter is prohibited from reverse rotation
51	User-defined fault 1	When the fault setting terminal is valid, the inverter outputs Err30 fault
52	User-defined fault 2	When the fault setting terminal is valid, the inverter outputs Err31 fault
53	Sleep input	The sleep function is controlled by external terminals to be valid or invalid, that is, when the switch is closed, the sleep function is forced to be valid, and when the switch is open, the inverter is forced to exit the sleep state and enter the wake-up operation state (not related to the PID operation).

Table 6-2 Multi-segment instruction function description

K4	K3	K2	K1	Frequency setting	Corresponding parameters
OFF	OFF	OFF	OFF	Multi-step speed 0	PC-00
OFF	OFF	OFF	ON	Multi-step speed 1	PC-01
OFF	OFF	ON	OFF	Multi-step speed 2	PC-02
OFF	OFF	ON	ON	Multi-step speed 3	PC-03
OFF	ON	OFF	OFF	Multi-step speed 4	PC-04
OFF	ON	OFF	ON	Multi-step speed 5	PC-05
OFF	ON	ON	OFF	Multi-step speed 6	PC-06
OFF	ON	ON	ON	Multi-step speed 7	PC-07
ON	OFF	OFF	OFF	Multi-step speed 8	PC-08
ON	OFF	OFF	ON	Multi-step speed 9	PC-09
ON	OFF	ON	OFF	Multi-step speed 10	PC-10
ON	OFF	ON	ON	Multi-step speed 11	PC-11

K4	K3	K2	K1	Frequency setting	Corresponding parameters
ON	ON	OFF	OFF	Multi-step speed 12	PC-12
ON	ON	OFF	ON	Multi-step speed 13	PC-13
ON	ON	ON	OFF	Multi-step speed 14	PC-14
ON	ON	ON	ON	Multi-step speed 15	PC-15

The 4 multi-segment command terminals can be combined into 16 states, each of which corresponds to 16 command setting values, as shown in Table 6-2.

Table 6-3 Function description of acceleration and deceleration time selection terminal

Terminal 2	Terminal 1	Acceleration Time selection	Corresponding Parameters
OFF	OFF	Acceleration time 1	P0-23、P0-24
OFF	ON	Acceleration time 2	P7-03、P7-04
ON	OFF	Acceleration time 3	P7-05、P7-06
ON	ON	Acceleration time 4	P7-07、P7-08

Function code	Name	Description (setting range)	Factory Default	Change
P5-10	DI terminal filter time	0.000~1.000s	0.010s	☆

Set the sensitivity of the DI terminal. If the digital input terminal is susceptible to interference and causes malfunction, this parameter can be increased, the anti-interference ability will be enhanced, but the sensitivity of the DI terminal will be reduced.

Function code	Name	Description (setting range)	Factory Default	Change
P5-11	Terminal command method	0~3	0	★

This parameter defines four different ways to control the operation of the inverter through external terminals.

### 0: Two-wire operation mode 1

This mode is the most commonly used two-wire mode. The forward and reverse rotation of the motor is determined by the FWD and REV terminal commands.

K1	K2	RUN command
0	0	STOP
1	0	Forward RUN
0	1	Reverse RUN
1	1	STOP

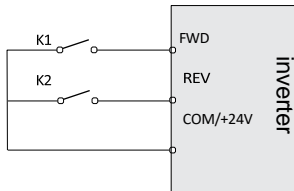

Fig.6-7 Two-wire operation mode 1

**1: Two-wire operation mode 2**

In this mode, FWD is the enable terminal. The direction is determined by the state of REV.

K1	K2	RUN command
0	0	STOP
0	1	STOP
1	0	Forward RUN
1	1	Reverse RUN

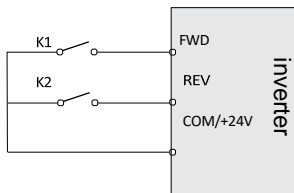

Fig.6-8 Two-wire operation mode 2

**2: Three-wire operation mode 1**

Din is the enable terminal in this mode, and the directions are controlled by FWD and REV respectively. But the pulse is valid, it must be done by disconnecting the Din terminal signal when stopping.

SB1: Stop button SB2:  
Forward button SB3:  
Invert button

Din is the multi-function input terminal of DI1~HDI, at this time, its corresponding terminal function should be defined as the No. 3 function "three-wire operation control".

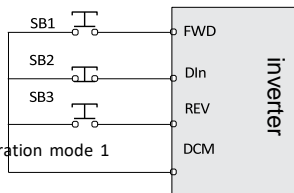

Fig.6-9 Three-wire operation mode 1

## 2: Three-wire operation mode

The enable terminal of this mode is Din, the running command is given by FWD, and the direction is determined by the state of REV.

The stop command is done by disconnecting the Din signal.

SB1: Stop button

SB2: Run button

Din is the multi-function input terminal of DI1~HD1, and its corresponding terminal function should be defined as the No. 3 function "three-wire operation control".

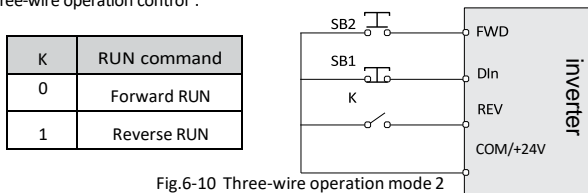

Fig.6-10 Three-wire operation mode 2

Function code	Name	Description (setting range)	Factory Default	Change
P5-12	Terminal UP/DOWN change rate	0.01Hz/s~100.00Hz/s	1.00Hz/s	☆

Terminal UP/DOWN to adjust the rate of change of the set frequency.

Function code	Name	Description (setting range)	Factory Default	Change
P5-13	Terminal valid logic 1	00000~11111	00000	★

0: High level

1: low level

Ones place: DI1

Tens place: DI2

Hundreds: DI3

Thousands: DI4

Ten thousand: DI5

DI1~DI5 terminal valid level selection.

## Chapter 6 Description of Function Codes

It is used to set the valid state mode of the digital input terminal.

When it is selected to be active at high level, it is valid when the corresponding DI terminal is connected to COM, and invalid when disconnected.

When it is selected to be active at low level, the corresponding DI terminal is invalid when connected with COM, and valid when disconnected.

Function code	Name	Description (setting range)	Factory Default	Change
P5-15	AI1 minimum input value	0.00~P5-17	0.00V	☆
P5-16	AI1 minimum input corresponding setting	-100.0%~100.0%	0.0%	☆
P5-17	AI1 maximum input value	P5-15~10.00V	10.00V	☆
P5-18	AI1 maximum input corresponding setting	-100.0%~100.0%	100.0%	☆
P5-19	AI1 input filter time	0.00s~10.00s	0.10s	☆

The above function codes define the relationship between the analog input voltage and the set value represented by the analog input. When the analog input voltage exceeds the set maximum input or minimum input range, the other part will be calculated as the maximum input or minimum input.

When the analog input is current input, 1mA current is equivalent to 0.5V voltage. (AI2 settings are the same as AI1 settings). In different applications, the nominal value corresponding to 100% of the analog setting is different, please refer to the description of each application section for details. The following illustrations illustrate several settings:

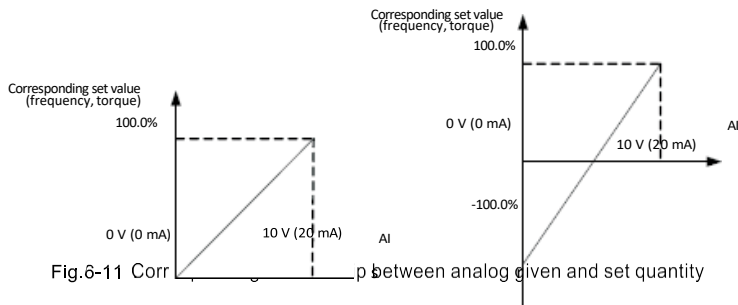

Fig.6-11 Correspondence between analog given and set quantity

Function code	Name	Description (setting range)	Factory Default	Change
P5-20	AI2 minimum input value	0.00~P5-22	0.00V	☆
P5-21	AI2 minimum input corresponding setting	-100.0%~100.0%	0.0%	☆
P5-22	AI2 maximum input value	P5-20~10.00V	10.00V	☆
P5-23	AI2 maximum input corresponding setting	-100.0%~100.0%	100.0%	☆
P5-24	AI2 input filter time	0.00s~10.00s	0.10s	☆

Same as AI1.

Function code	Name	Description (setting range)	Factory Default	Change
P5-30	PULSE (pulse) input minimum frequency	0.00KHz~P5-32	0.00KHz	☆
P5-31	PULSE (pulse) input minimum frequency corresponding setting	-100.0%~100.0%	0.0%	☆
P5-32	PULSE (pulse) input maximum frequency	P5-30~50.00KHz	50.00KHz	☆
P5-33	PULSE (pulse) input maximum frequency corresponding setting	-100.0%~100.0%	100.0%	☆

PULSE input quantization is similar to analog input quantization.

Function code	Name	Description (setting range)	Factory Default	Change
P5-35	DI1 turn-on delay time	0.0s~3600.0s	0.0s	☆
P5-36	DI1 off delay time	0.0s~3600.0s	0.0s	☆
P5-37	DI2 turn-on delay time	0.0s~3600.0s	0.0s	☆
P5-38	DI2 off delay time	0.0s~3600.0s	0.0s	☆
P5-39	DI3 turn-on delay time	0.0s~3600.0s	0.0s	☆
P5-40	DI3 off delay time	0.0s~3600.0s	0.0s	☆

It is used to set the delay time for the inverter to change the state of the DI terminal. Currently, only DI1, DI2, and DI3 have the function of setting the delay time.

## Chapter 6 Description of Function Codes

Function code	Name	Description (setting range)	Factory Default	Change
P5-41	AI1 is selected as DI terminal function	0~53	0	★
P5-42	Function selection selection when AI2 is used as DI terminal	0~53	0	★

This parameter sets whether to use AI as a digital DI terminal. When AI is used as a digital DI terminal, its function is exactly the same as that of ordinary DI.

Special attention is: the input range of AI is still unchanged from 0 to 10V. When the AI voltage is >6V, it is a high level, and when it is <4V, it is a low level. There is a 2V hysteresis in between. That is, when AI rises from 0V to >6V, it is a high level, and it is a low level when it decreases from >6V to 4V.

Function code	Name	Description (setting range)	Factory Default	Change
P5-44	Valid mode selection when AI is used as DI terminal	0X00~0X11	0X00	☆

This parameter is used to set the level selection when AI is used as a digital DI terminal.

0: Active high level, AI is high level when AI rises from 0V to >6V, and is low level when it decreases from >6V to 4V.

1: Low level is active, AI is low level when AI rises from 0V to <6V, and it is low level when it decreases from >6V to 4V.

Ones place, AI1:

Ten, AI2:

Function code	Name	Description (setting range)	Factory Default	Change
P5-45	AI curve selection	00~22	00	☆

This parameter is used for AI curve selection, 0 is a straight line, 1 and 2 are 4-point curves. And each curve has corresponding function code settings.

**Ones place: AI1**

0: 2-point straight line P5-15~P5-19 1:

Multi-point curve 1: PE-00~PE-07

2: Multi-point curve 2: PE-08~PE-15

**Tenth place: AI2**

0: 2-point straight line P5-20~P5-24 1:

Multi-point curve 1: PE-00~PE-07

2: Multi-point curve 2: PE-08~PE-15

**Hundreds: reserved**

Function code	Name	Description (setting range)	Factory Default	Change
P5-46	AI signal input type selection	00~11	00	☆

This parameter is used to set the AI signal input type. The input signal type selection of AI needs to correspond one-to-one with the input type (voltage type, current type) of hardware AI, which is beneficial to improve the accuracy and linearity of AI signal sampling.

**Ones place: AI1,****Tens place: AI2;****0: Voltage type****1: Current type**

## Group P6: Output terminal

KD600 series inverters come standard with 2 multi-function analog output terminals, 1 multi-function digital output terminal, and 2 multi-function relay output terminals.

Function code	Name	Description (setting range)	Factory Default	Change
P6-00	Control board relay RELAY1 output (TA/TB/TC) selection	0~45	2	★
P6-01	Control board relay RELAY2 output (RA/RB/RC) selection	0~45	1	★
P6-02	Y1 output selection	0~45	1	★

The function selection of multi-function output terminal is as follows:

Value	Function	Description
0	No output	The terminal has no function.
1	Inverter is running	Indicates that the inverter is running, and there is an output frequency (which can be zero), and the ON signal is output at this time.
2	Fault output (stop)	When the inverter fails, output ON signal.
3	Frequency-level detection FDT1 output	Please refer to the detailed description of function codes P7-22 and P7-23.
4	Frequency arrives	Frequency arrives, see P7-24 for details.
5	Running at zero speed	When the inverter is running and the output frequency is zero, the ON signal is output.
6	Motor overload pre-warning	The motor overload protection is judged according to the early warning threshold, and the ON signal is output after exceeding the forecast setting value. For details, please refer to P9-00~P9-02.
7	AC drive overload pre-warning	10S before inverter overload protection occurs, output ON signal.
8	PLC cycle complete	When simple PLC completes one cycle, the terminal outputs a pulse signal with width of 250 ms.
9	Accumulative running time reached	If the accumulative running time of the AC drive exceeds the time set in F09.16, the terminal becomes ON.

Value	Function	Description
10	Frequency limited	When the set frequency exceeds the upper and lower frequency limits and the output frequency of the inverter reaches the upper and lower frequency limits, the ON signal is output.
11	Ready to run	The main circuit and control circuit power supply is established, the inverter protection function does not act, the inverter is in a running state, and the ON signal is output.
12	AI1> AI2	When the value of analog input AI1 is greater than the other input AI2, output ON signal.
13	upper limit frequency reached	When the running frequency reaches the upper limit frequency P0-16, the ON signal is output
14	Lower limit frequency reached	When the running frequency reaches the lower limit frequency P0-18, the ON signal is output
15	Brown-out status output	When the inverter is under voltage state, it outputs ON signal
16	Communication settings	For communication settings, please refer to Appendix A Communication Protocol
17	Timer output	When the timer can realize the time relay function, when the valid time of the timer input signal reaches the set closing and opening time, the timing output function is valid. It needs to be used in conjunction with No. 25 function of DI input and P7-39 and P7-40.
18	Running in reverse	When the inverter is running in reverse, it outputs ON signal.
19	Reserved	reserved
20	Set length reached	When the detected actual length exceeds the set length, the ON signal is output
21	Torque limit	When the torque limit function is used, the stall protection function will automatically act
22	Current 1 arrives	Please refer to the description of function codes P7-45 and P7-46.
23	Frequency 1 arrives	Please refer to the description of function codes P7-43 and P7-44.
24	Module temperature reached	When the inverter module radiator temperature (P7-32) reaches the set module temperature reaching value (P7-69), the ON signal is output

## Chapter 6 Description of Function Codes

Value	Function	Description
25	Downloading	When the inverter is in the state of off-load, the ON signal is output.
26	The cumulative power-on time arrives	When the accumulative power-on time (P7-33) of the inverter exceeds the power-on arrival time set by P7-51, it will output ON signal.
27	The running time has arrived	When the timing function selection (P7-36) is valid, the inverter will output ON signal after the current running time reaches the set timing time (P7-38).
28	Reserved	Reserved
29	Set count value reached	When the count value reaches the value set by Pb-08, the ON signal is output.
30	The specified count value is reached	When the detected actual length count value reaches the length count value set by Pb-09, the ON signal is output.
31	Motor 1, Motor 2 indication	When the current motor is No. 2 motor, the ON signal is output.
32	Brake control output	When the holding brake is valid, the ON signal will be output. For details, please refer to the settings in Group B5.
33	Running at zero speed 2	When the output frequency of the inverter is 0, the ON signal is output. This signal is also ON in stop state.
34	Frequency level detection PDT2 arrival	Please refer to the description of function codes P7-55 and P7-56.
35	Zero current state	Please refer to the description of function codes P7-59 and P7-60.
36	Software current overrun	Please refer to the description of function codes P7-61 and P7-62.
37	When the lower limit frequency is reached, it will also output when it stops	When the running frequency reaches the lower limit frequency, the ON signal is output. This signal is also ON in the stop state.
38	Alarm output	When a fault occurs in the inverter, and the processing mode of the fault is to continue running, the inverter will output an alarm.
39	Reserved	Reserved
40	AI1 input overrun	When the value of analog input AI1 is less than P7-67 (AI1 input protection lower limit) or greater than P7-68 (AI1 input protection upper limit), the ON signal is output.

Value	Function	Description
41	Reserved	Reserved
42	Reserved	Reserved
43	Frequency up to 2	Please refer to the description of function codes P7-57 and P7-58.
44	Current reaches 2	Please refer to the description of function codes P7-63 and P7-64.
45	Fault output (no output under voltage)	When the inverter fails and it is not an undervoltage fault, the ON signal is output.

Function code	Name	Description (setting range)	Factory Default	Change
P6-04	FM terminal output mode selection	0~1	0	☆
P6-05	FMR output selection	0~45	0	☆

The FM terminal can be used as the high-speed pulse terminal FMP (P6-04=0) or as the open-collector switch output terminal (P6-04=1). When FM terminal is used as FMP, its maximum output frequency is set by P6-12, and its corresponding function output is set by P6-11.

Function code	Name	Description (setting range)	Factory Default	Change
P6-09	AO1 output selection	0~16	0	☆
P6-10	AO2 output selection		0	☆
P6-11	FMP output selection		0	☆

The output range of analog output AO1 and AO2 is 0V~10V, or 0mA~20mA.

The scale relationship between the range of analog output and the corresponding function is shown in the following table:

Value	Function	Description
0	Running frequency	0~Maximum output frequency, that is, 100% corresponds to the maximum frequency
1	Setting frequency	0~Maximum output frequency, that is, 100% corresponds to the maximum frequency

## Chapter 6 Description of Function Codes

Value	Function	Description
2	Output current	0 to 2 times the rated current of the motor, that is, 100% corresponds to 2 times the rated current of the motor
3	Output voltage	0 to 2 times the rated power, that is, 100% corresponds to 2 times the rated power of the motor
4	Output power	0~1.2 times the rated voltage of the inverter, that is, 100% corresponds to 1.2 times the rated voltage of the inverter
5	AI1	0V~10V (or 0~20mA), that is, 100% corresponds to 10V or 20mA
6	AI2	0V~10V (or 0~20mA), that is, 100% corresponds to 10V or 20mA
7	Communication settings	0.0%~100.0%, please refer to Appendix A "Modbus Communication Protocol" for use
8	Output torque (absolute value)	0 to 2 times the rated torque of the motor, that is, 100% corresponds to 2 times the rated torque of the motor
9	Length	0 to 2 times the set length, that is, 100% corresponds to 2 times the set length
10	Count value	0~2 times the set count value, that is, 100% corresponds to 2 times the set count value
11	Motor speed	0 to the speed corresponding to the maximum frequency P0-14, that is, 100% corresponds to the speed corresponding to P0-14
12	Bus voltage	0V~1000V, that is, 100% corresponds to 1000V
13	PULSE pulse input	0.01kHz~100.00kHz
14	Output current	100% corresponds to 1000.0A
15	The output voltage	0V~1000V
16	Output torque (actual value)	-2 times the rated torque of the motor ~ 2 times the rated torque of the motor

Function code	Name	Description (setting range)	Factory Default	Change
P6-12	FMP output maximum frequency	0.01kHz~100.00kHz	50.00	☆
P6-13	AO1 output lower limit	-100.0%~P6-15	0.0%	☆
P6-14	The lower limit corresponds to AO1 output	0.00V~10.00V	0.00V	☆

Function code	Name	Description (setting range)	Factory Default	Change
P6-15	AO1 output upper limit	P6-13~100.0%	100.0%	☆
P6-16	The upper limit corresponds to AO1 output	0.00~10.00V	10.00V	☆
P6-17	AO2 output lower limit	-100.0%~P6-19	0.0%	☆
P6-18	The lower limit corresponds to the AO2 output	0.00V~10.00V	0.00V	☆
P6-19	AO2 output upper limit	P6-17~100.0%	100.0%	☆
P6-20	The upper limit corresponds to AO2 output	0.00~10.00V	10.00V	☆

The above function codes define the corresponding relationship between the output value and the analog output. When the output value exceeds the set maximum output or minimum output range, it is calculated by the upper limit output or the lower limit output.

When the analog output is current type output, 1mA current corresponds to 0.5V voltage. In different applications, the analog output corresponding to 100% of the output value is different. As shown in Figure 6-12 below, there are two different linear graphs a and b.

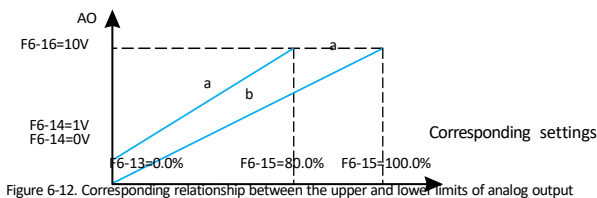

Figure 6-12. Corresponding relationship between the upper and lower limits of analog output

Function code	Name	Description (setting range)	Factory Default	Change
P6-26	Main relay T off delay	0.0s~3600.0s	0.0s	☆
P6-27	Main relay R off delay	0.0s~3600.0s	0.0s	☆
P6-28	Y1 low level output delay	0.0s~3600.0s	0.0s	☆

It is used to set the delay time of the inverter to different output state changes when the Y terminal state changes or the relay output state changes.

**Group P7: Accessibility and keyboard display**

Function code	Name	Description (setting range)	Factory Default	Change
P7-00	Jog running frequency	0.00Hz~Maximum frequency	6.00Hz	☆
P7-01	Jog acceleration time	0.0s~3000.0s	10.0s	☆
P7-02	Jog deceleration time	0.0s~3000.0s	10.0s	☆

Define the given frequency and acceleration/deceleration time of the inverter when jogging. The jog process starts and stops according to start mode 0 (P1-00, direct start) and stop mode 0 (P1-13, deceleration stop).

Jog acceleration time refers to the time required for the inverter to accelerate from 0Hz to the maximum output frequency (P0-14).

Jog deceleration time refers to the time required for the inverter to decelerate from the maximum output frequency (P0-14) to 0Hz.

Function code	Name	Description (setting range)	Factory Default	Change
P7-03	Acceleration time 2	0.0s~3000.0s	10.0s	☆
P7-04	Deceleration time 2	0.0s~3000.0s	10.0s	☆
P7-05	Acceleration time 3	0.0s~3000.0s	10.0s	☆
P7-06	Deceleration time 3	0.0s~3000.0s	10.0s	☆
P7-07	Acceleration time 4	0.0s~3000.0s	10.0s	☆
P7-08	Deceleration time 4	0.0s~3000.0s	10.0s	☆

The acceleration and deceleration time can be selected from P0-23 and P0-24 and the above three acceleration and deceleration times. Their meanings are the same, please refer to the related descriptions of P0-23 and P0-24.

The acceleration and deceleration time 1~4 during the operation of the inverter can be selected through different combinations of the multi-function digital input terminals DI. Please refer to function codes P5-00~P5-04.

Function code	Name	Description (setting range)	Factory Default	Change
P7-09	Hop Frequency 1	0.00Hz~Maximum frequency	0.00Hz	☆
P7-10	Hop Frequency 1 Amplitude	0.00Hz~Maximum frequency	0.00Hz	☆

Function code	Name	Description (setting range)	Factory Default	Change
P7-11	Hop Frequency 2	0.00Hz~Maximum frequency	0.00Hz	☆
P7-12	Hop Frequency 2 Amplitude	0.00Hz~Maximum frequency	0.00Hz	☆

When the set frequency is within the jump frequency range, the actual operating frequency will run at the jump frequency boundary closer to the set frequency. By setting the jump frequency, the inverter can avoid the mechanical resonance point of the load. This inverter can set 2 jump frequency points. If two adjacent jump frequencies are set to the same value, this function will not work at that frequency.

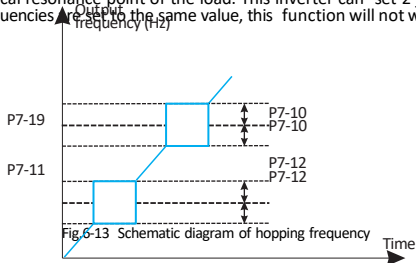

Function code	Name	Description (setting range)	Factory Default	Change
P7-15	Forward and reverse dead time	0.0s~3000.0s	0.0s	☆

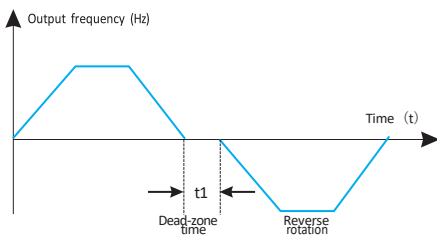

Fig.6-14 Schematic diagram of forward and reverse dead time

## Chapter 6 Description of Function Codes

Function code	Name	Description (setting range)	Factory Default	Change
P7-16	Keyboard Knob Accuracy	0~8	2	☆

This parameter is used to define the resolution of the operation keyboard to adjust the set frequency in the monitoring menu mode. When the Up/Down button is operated, the frequency is added or subtracted with the set resolution.

0: Default mode;

1: 0.1Hz;

2: 0.5Hz;

3: 1Hz;

4: 2Hz;

5: 4Hz;

6: 5Hz;

7: 8Hz;

8: 10Hz.

Function code	Name	Description (setting range)	Factory Default	Change
P7-17	The frequency is lower than the lower limit frequency processing	0~2	0	☆

0: Run at the lower frequency limit 1:

Shutdown

2: Running at zero speed

Select the running state of the inverter when the set frequency is lower than the lower limit frequency. In order to avoid the motor running at low speed for a long time, this function can be used to select stop.

Function code	Name	Description (setting range)	Factory Default	Change
P7-18	Sag rate	0.0%~100.0%	0.0%	☆

This function is generally used for load distribution when multiple motors drive the same load. Droop control means that as the load increases, the output frequency of the inverter decreases, so that when multiple motors drive the same load, the output frequency of the motor in the load drops more, so that the load of the motor can be reduced and the multi-motor can be realized. Load evenly.

This parameter refers to the drop value of the output frequency when the inverter outputs the rated load.

Function code	Name	Description (setting range)	Factory Default	Change
P7-19	Delay time for frequency lower than lower limit shutdown	0.0s~600.0s	0.0s	☆

When the set frequency is lower than the lower limit frequency and the action is selected as stop, the action of P7-19 will be delayed.

Function code	Name	Description (setting range)	Factory Default	Change
P7-20	Set cumulative operating time	0h~65000h	0h	☆

Preset the running time of the inverter. When set to 0, this function has no effect.

When the accumulated running time (P7-34) reaches the set running time, the multi-function digital terminal of the inverter outputs the running time arrival signal (multi-function output No. 26) ON signal, and the inverter reports the accumulated time arrival fault Err40 at the same time.

Function code	Name	Description (setting range)	Factory Default	Change
P7-21	Jog priority	0~2	1	☆

0: invalid

1: Jog priority mode 1

2: Jog priority mode 2

1) When the user fails or the PID is lost, the jog is still valid;

2) The stop mode and DC braking can be set.

Function code	Name	Description (setting range)	Factory Default	Change
P7-22	Frequency detection value (PDT1 level)	0.00Hz~Maximum frequency	50.00Hz	☆
P7-23	Frequency check hysteresis value (PDT1 hysteresis)	0.0%~100.0%	5.0%	☆

Set the detection value of the output frequency and the hysteresis value of the output action release.

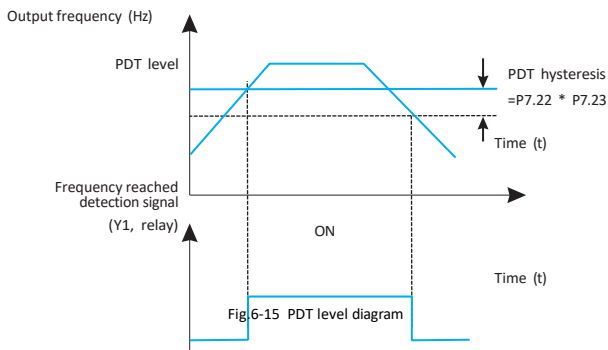

Function code	Name	Description (setting range)	Factory Default	Change
P7-24	Frequency arrival detection width	0.0%~100.0%	0.0%	☆

When the output frequency of the inverter reaches the set frequency value, this function can adjust the detection amplitude. As shown below:

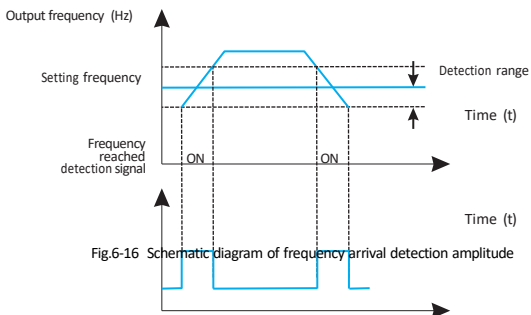

Function code	Name	Description (setting range)	Factory Default	Change
P7-26	Fan control	0~1	0	★

0: The fan runs continuously;

1: The fan runs when the inverter is running;

It is used to select the action mode of the cooling fan. When it is selected as 1, the inverter will run the fan in the running state. If the radiator temperature is higher than 40 degrees in the stop state, the fan will run. In the stop state, the fan will not work when the radiator is lower than 40 degrees. run.

When 0 is selected, the fan keeps running after power-on.

Function code	Name	Description (setting range)	Factory Default	Change
P7-27	STOP/RESET function	0~1	0	☆

0: Only valid in keyboard control ;

1: The stop or reset function is valid in all control modes.

Function code	Name	Description (setting range)	Factory Default	Change
P7-28	Quick /JOG key function selection	0~3	0	★

The Quick/Jog key is a multi-function key, and the function of the Quick/Jog key can be set through this function code. This key can be used to switch between stop and running.

### 0: Forward jog

Forward jog (FJOG) is realized through the keyboard Quick/Jog key.

### 1: Forward and reverse switching

Use the Quick/Jog key to switch the direction of the frequency command. This function is only valid when the command source is the command channel of the operation panel.

### 2: Reverse jog

Reverse jog (RJOG) is realized through the keyboard Quick/Jog key.

### 3: Switch between panel control and remote control (terminal or communication)

Refers to the switching of the command source, that is, the switching between the current command source and keyboard control (local operation). If the current command source is keyboard control, the function of this key is invalid.

Function code	Name	Description (setting range)	Factory Default	Change
P7-29	LED running display	0000~0xPPFF	H.441F	☆

This function code sets the parameters displayed by the LED when the inverter is running. When the corresponding bit of this function code is set to 1, the monitoring parameter corresponding to this bit is displayed. When multiple function codes are selected for display, they can be switched by the keys on the operation panel.

**Note:**



When the function code is set to H.0000, the running frequency is displayed by default.

**Setting example:**

The hexadecimal value corresponding to each quantity to be displayed has been calculated. As shown in Figure 5-7, the displayed quantities correspond to the set values one by one. For example, to display only the bus voltage, set the corresponding 0004 to P7-29 (H.0004). If multiple values need to be displayed, add the corresponding values one by one. For example, to display the bus voltage and output current, set 0004+0010=0014, and set 0014 to P7-29 (H.0014). The numbers of the addition result exceeding 10 are represented by A B C D E F respectively, and the numbers represented are 10 11 12 13 14 15.

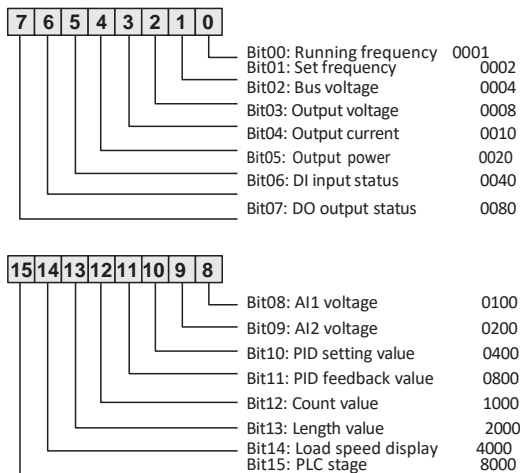

Figure 6-17. LED operation display bit map

Function code	Name	Description (setting range)	Factory Default	Change
P7-30	LED stop display	0001~0x1Pff	H.0043	☆

This function code sets the parameters displayed by LED when the inverter stops. When the corresponding bit of this function code is 1, the monitoring parameter corresponding to this bit is displayed. When multiple function codes are selected for display, they can be switched by the keys on the operation panel.

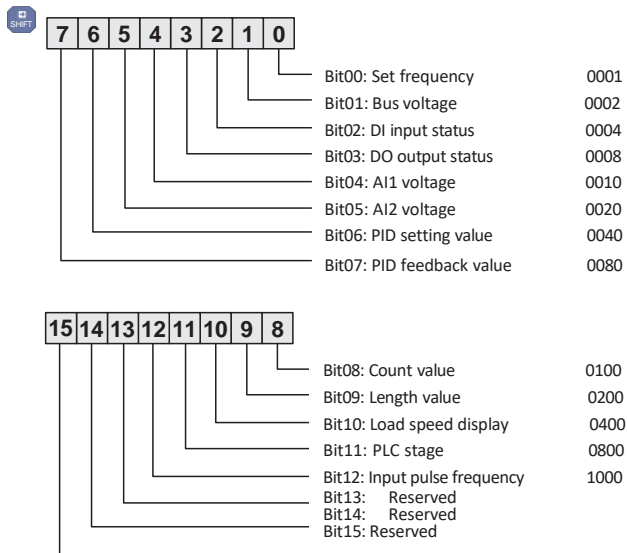

Figure 6-18. LED stop display corresponding map

Function code	Name	Description (setting range)	Factory Default	Change
P7-31	Load speed display factor	0.001~655.00	1.000	☆

Through this parameter, the output frequency of the inverter and the load speed are corresponded. It is used for setting when there is no high-speed pulse and the load speed needs to be displayed, the load speed (U1-22)=P7-31\*running frequency. The unit can be speed or Hz, please set the specific parameter value according to the actual situation.

## Chapter 6 Description of Function Codes

Function code	Name	Description (setting range)	Factory Default	Change
P7-32	Radiator temperature	12°C~100°C	Measured value	●

Displays the temperature of the IGBT of the inverter module. The over-temperature protection value of the IGBT of the inverter module of different models may be different.

Function code	Name	Description (setting range)	Factory Default	Change
P7-33	Cumulative power-on time	0h~65535h	Measured value	●

Record the cumulative power-on time of the inverter, if the power-on time is less than 1 hour, it will not be recorded.

Function code	Name	Description (setting range)	Factory Default	Change
P7-34	Cumulative running time	0h~65535h	Measured value	●

Record the accumulated running time of the inverter, if the running time is less than 1 hour, it will not be recorded.

Function code	Name	Description (setting range)	Factory Default	Change
P7-36	Current running timing enable selection	0~1	0	★

**0:Disable**

**1: Enable, When the time is up, a fault is reported**

**2: Enable, When the time is up, a fault is not reported**

Function code	Name	Description (setting range)	Factory Default	Change
P7-37	Selection of timing source for the current run	0~1	0	★

**0: Digital setting P7-38;**

**1: AI1 (AI takes P7-38 as 100%);**

**2: AI2.**

Function code	Name	Description (setting range)	Factory Default	Change
P7-38	Current running time set value	0.0min~6500.0min	0.0min	☆

When the current running timing of P7-36 is valid, and the current running time source selects 0: P7-38 setting, and the switch output selects No. 27 function, the running time of the inverter reaches the set time, outputs the ON signal, and at the same time converts the frequency. The device reports that the running time has reached the fault Err39.

Function code	Name	Description (setting range)	Factory Default	Change
P7-39	High level timing	0.0s~6000.0s	2.0s	☆
P7-40	low level timing	0.0s~6000.0s	2.0s	☆

When the timer input terminal "on" is longer than P7-39, the output of this timer function is turned on.

When the timer input terminal "disconnect" is longer than P7-40, the output of the timer function is disconnected.

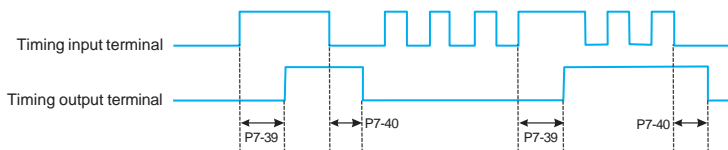

Fig.6-19 Schematic diagram of timer input and output operation

Function code	Name	Description (setting range)	Factory Default	Change
P7-41	Activate the protection function	0~1	1	☆

**0: Invalid (start terminal command is valid and start directly)**

**1: Valid**

This parameter is used to improve the safety protection factor. If it is set to 1, it has two effects:

1) The running command exists when the inverter is powered on, the running command must be removed before the running protection state can be eliminated.

## Chapter 6 Description of Function Codes

2) If the running command still exists when the inverter is reset to fault, the running command must be removed to eliminate the running protection state.

This prevents the motor from running automatically without knowing it, creating a hazard.

If it is set to 0, and the running command exists when the inverter is powered on, the inverter will start directly.

Function code	Name	Description (setting range)	Factory Default	Change
P7-43	Frequency reaches detection value 1	0.00Hz~P0-14	50.00Hz	☆
P7-44	Frequency detection value 1 arrival width	0.0%~100.0%	0.0%	☆

When the output frequency of the inverter is within the range of the positive and negative detection amplitudes of the detection value 1, the multi-function output terminal will output an ON signal. Please refer to Figure 6-16 for the DO output action.

Function code	Name	Description (setting range)	Factory Default	Change
P7-45	Current reaches detection value 1	0.0%~300.0%	100.0%	☆
P7-46	Current detection value 1 arrival width	0.0%~300.0%	0.0%	☆

When the output current of the inverter is within the positive and negative detection width of the detection value 1, the multi-function output terminal of the inverter outputs the ON signal.

Function code	Name	Description (setting range)	Factory Default	Change
P7-49	user password	0~65535	0	☆

If P7-49 is set to any non-zero number, the password protection function will take effect. The next time you enter the menu, you must enter the correct password, otherwise you cannot view and modify the function parameters, please keep in mind the set user password.

If P7-49 is set to 0, the set user password will be cleared and the password protection function will be invalid.

Function code	Name	Description (setting range)	Factory Default	Change
P7-50	Whether the jump frequency is valid during acceleration and deceleration	0~1	0	☆

0: invalid;

1: Valid.

Function code	Name	Description (setting range)	Factory Default	Change
P7-51	Set the power-on arrival time	0h~65530h	0h	☆

When it is 0, the timing function is invalid.

When the cumulative power-on time of the inverter reaches the value set by P7-51, the multi-function output terminal function (26: cumulative power-on time arrival) outputs ON signal.

Function code	Name	Description (setting range)	Factory Default	Change
P7-53	Acceleration time 1/2 switching frequency point	0.00Hz~P0-14	0.00Hz	☆
P7-54	Deceleration time 1/2 switching frequency point	0.00Hz~P0-14	0.00Hz	☆

When the running frequency during acceleration is less than P7-53, select acceleration time 2 (P7-03) for acceleration time; when the running frequency during acceleration is greater than P7-53, select acceleration time 1 (P0-23);

When the running frequency during deceleration is greater than P7-54, the acceleration time selects acceleration time 1 (P0-24), and when the running frequency during deceleration is less than P7-54, selects deceleration time 2 (P7-04).

Function code	Name	Description (setting range)	Factory Default	Change
P7-55	Frequency detection value (PDT2 level)	0.00Hz~P0-14	50.00Hz	☆
P7-56	Frequency detection PDT2 hysteresis value	0.0%~100.0%	5.0%	☆

It has the same meaning as PDT1, please refer to P7-22, P7-23 and Figure 5-15 for details.

## Chapter 6 Description of Function Codes

Function code	Name	Description (setting range)	Factory Default	Change
P7-57	Frequency reaches detection value 2	0.00Hz~P0-14	50.00Hz	☆
P7-58	Frequency arrival detection 2 amplitude	0.0%~100.0%	0.0%	☆

The meaning is the same as that of frequency arrival detection value 1, please refer to P7-43, P7-44 and Fig. 5-16 for details.

Function code	Name	Description (setting range)	Factory Default	Change
P7-59	Zero current detection value	0.0%~300.0%	10.0%	☆
P7-60	Zero current detection delay time	0.01s~300.00s	1.00s	☆

When the output current of the inverter during operation is less than or equal to the zero current detection level, and the duration exceeds the zero current detection delay time, and the inverter multi-function terminal selects the No. 35 function, the ON signal is output.

Function code	Name	Description (setting range)	Factory Default	Change
P7-61	Output current amplitude detection	20.0%~400.0%	200.0%	☆
P7-62	Software overcurrent maximum allowable time	0s~6500.0s	0s	☆

When the inverter is running and the output current is greater than the output current amplitude detection value P7-61, and the duration exceeds the software overcurrent point detection delay time P7-62, and the inverter multi-function output terminal selects 36, the ON signal is output.

Function code	Name	Description (setting range)	Factory Default	Change
P7-63	Current reaches detection value 2	20.0%~300.0%	100.0%	☆
P7-64	Current arrival detection 2 amplitude	0.0%~300.0%	0.0%	☆

The meaning is the same as that of current reaching detection 1, please refer to the description of P7-45 and P7-46 for details.

Function code	Name	Description (setting range)	Factory Default	Change
P7-65	LED running display parameter 2	0x0~0x1PF	H.010	

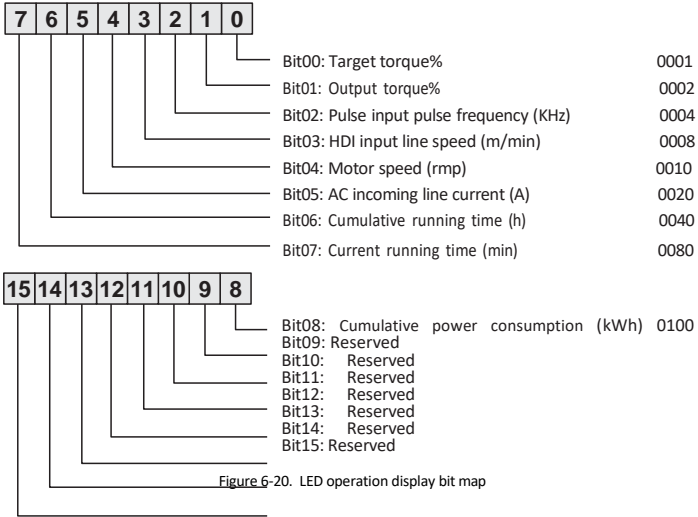

Figure 6-20. LED operation display bit map

Function code	Name	Description (setting range)	Factory Default	Change
P7-67	AI1 input voltage lower limit	0.00V~P7-68	2.00V	☆
P7-68	AI1 input voltage upper limit	P7-67~11.00V	8.00V	☆

When the value of the analog input AI1 is less than P7-67, or the AI1 input is greater than P7-68, the multi-function terminal of the inverter outputs the "AI1 input overrun" ON signal, which is used to indicate whether the input voltage of AI1 is within the set range.

## Chapter 6 Description of Function Codes

Function code	Name	Description (setting range)	Factory Default	Change
P7-69	Module temperature reached	0°C~90°C	70°C	☆

When the module temperature of the inverter reaches the set value of P7-69, the multi-function output terminal outputs ON signal.

Function code	Name	Description (setting range)	Factory Default	Change
P7-70	Output power display correction factor	0.001~3.000	1.000	☆

Output power display = output power \*P7-70, which can be viewed through monitoring code U1-05.

Function code	Name	Description (setting range)	Factory Default	Change
P7-71	Linear velocity display correction factor	0.000~60.000	1.000	☆

Linear speed=P7-71\*Number of HDI pulses sampled per second/Pb-07, which can be viewed through monitoring parameter U1-14.

Function code	Name	Description (setting range)	Factory Default	Change
P7-72	Cumulative power consumption (kWh)	0~65535	Measured value	●

The accumulated power consumption of the inverter so far can only be viewed but not modified.

Function code	Name	Description (setting range)	Factory Default	Change
P7-73	Performance software version	0.00~655.35	##	●

Performance software version number.

Function code	Name	Description (setting range)	Factory Default	Change
P7-74	Functional software version	0.00~655.35	##	●

Function software version number.

Function code	Name	Description (setting range)	Factory Default	Change
P7-75	Enhanced function parameter display selection	0.00~655.35	0	☆

Function software version number.

Function code	Name	Description (setting range)	Factory Default	Change
P7-76	Motor speed display correction factor	0.0010~3.0000	1.0000	☆

## Group P8: Communication parameters

Function code	Name	Description (setting range)	Factory Default	Change
P8-00	Baud rate setting	0~7	2	☆
P8-01	Data Format	0.0s~3000.0s	0	☆

Baud rate settings:

- 0: 300BPS
- 1: 600BPS
- 2: 1200BPS
- 3: 2400BPS
- 4: 4800BPS
- 5: 9600BPS
- 6: 19200BPS
- 7: 38400BPS

The baud rate is the data transmission rate between the host computer and the inverter. The higher the baud rate, the faster the communication speed.

Data Format:

- 0: No checksum: Data format <8,N,2>
- 1: Even parity: data format <8,E,1>
- 2: Odd parity: data format <8,O,1>
- 3: No check 1: Data format <8,N,1>

Note that the baud rate and data format set by the host computer and the inverter must be consistent, otherwise, the communication cannot be carried out.

Function code	Name	Description (setting range)	Factory Default	Change
P8-02	Mailing address	0~247	1	☆

When the local address is set to 0, that is, the broadcast address, which realizes the broadcast function of the upper computer.

### Note:

The address of this machine is unique (except for broadcasting), which is the basic condition for realizing point-to-point communication between the host computer and the inverter.

Function code	Name	Description (setting range)	Factory Default	Change
P8-03	Response time	0ms~30ms	2ms	☆

The response delay refers to the interval time from the end of the inverter data reception to the time when the data is sent to the upper computer. If the response delay is less than the system processing time, the response delay is subject to the system processing time. If the response delay is longer than the system processing time, after the system has processed the data, it will wait until the response delay time is reached. send data.

Function code	Name	Description (setting range)	Factory Default	Change
P8-04	Communication timeout	0ms~30ms	0.0s	☆

When the function code is set to 0.0s, the communication timeout parameter is invalid. When the function code is set to non-zero, if the interval between one communication and the next communication exceeds the communication timeout time, the system will report a communication failure error (Err27), which is usually set to be invalid. If this parameter is set in a system with continuous communication, the communication status can be monitored.

Function code	Name	Description (setting range)	Factory Default	Change
P8-05	Communication format selection	0~1	0	☆

0: Standard Modbus protocol.

1: When the command is read, the number of bytes returned by the slave is one byte more than the standard Modbus protocol. Refer to Appendix A for the description of the communication protocol.

Function code	Name	Description (setting range)	Factory Default	Change
P8-06	Background software monitoring function	0~1	0	☆

0: Disable, default 485 communication function;

1: On, the background software monitoring function, the 485 communication function cannot be used at this time.

## Group P9: Fault and Protection

Function code	Name	Description (setting range)	Factory Default	Change
P9-00	Motor overload protection selection	0~1	1	☆

0: No motor overload protection function, there is a danger of motor overheating damage, it is recommended to heat the relay between the inverter and the motor;

1: There is a motor overload protection function, and the relationship between the protection time and the motor current is shown in Figure 6-20.

Function code	Name	Description (setting range)	Factory Default	Change
P9-01	Motor overload protection gain	0.10~10.00	1.00	☆

In order to effectively protect the overload of different motors, it is necessary to set P9-01 appropriately. For the usage method, refer to Figure 5-21 of the inverse time limit curve of motor overload protection. In the figure, L1 is the relationship between the motor protection time and the motor current when P9-01=1. When the user needs to change the protection time of a certain current of the motor, he only needs to change P9-01. The time relationship is:

$$\text{Required protection time } T = P9-01 \times T(L1)$$

### Example:

When the user needs to modify the protection time of 150% rated current to 3 minutes, first find in Figure 5-20 that the protection time of 150% motor current is 6.0 minutes, then P9-01

= required protection time  $T/T(L1) = 3\text{min}/6\text{min} = 0.5$ .

The maximum time of motor overload protection is 100 minutes, and the shortest overload time is 0.1 minutes. Please set it according to your needs. And when the motor is overloaded, the inverter will report Err14 to avoid damage to the motor due to continuous heating.

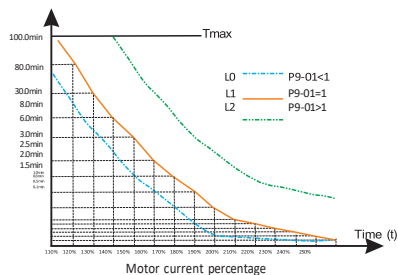

Figure 6-21. Motor overload protection curve

**Note:**

By default, there is no overload protection below 110% of the rated current of the motor. When you need to achieve overload protection below 110% of the rated current of the motor, please set the motor overload protection current coefficient P9-35 appropriately.

$$\text{Motor current percentage} = (\text{actual current}/\text{rated current}) \times \text{P9-35}$$

**Example:**

The user needs to set the protection time to 30.0min when the rated current is 90%, first find in Figure 5-20 that the current corresponding to 30.0min on L1 is 130%, P9-35=(130%/90%)

$\times 100\% = 144\%$ . Note: The minimum current protection value is 55%.

Function code	Name	Description (setting range)	Factory Default	Change
P9-02	Motor overload warning coefficient (%)	50%~100%	80%	☆

This function is used to give an early warning signal to the control system before the motor overload fault protection, so as to pre-protect the motor overload.

The larger the value is, the smaller the early warning is.

When the cumulative output current of the inverter is greater than the product of the set overload protection time and P9-02, the multi-function digital output terminal selects "motor overload pre-alarm ON" to output the switch signal. The terminal function is 6, see P6-00~P6-02 function code setting instructions for details.

Function code	Name	Description (setting range)	Factory Default	Change
P9-03	Overvoltage Stall Protection Gain	000~100	030	☆
P9-04	Overvoltage stall protection voltage	200.0~1200.0V	760.0V	★

<1> This value is the factory value of 380V inverter, and the factory value of 200V inverter is 380V.

During the deceleration process of the inverter, when the DC bus voltage exceeds the overvoltage stall protection voltage, the inverter stops decelerating to maintain the current operating frequency, and continues to decelerate after the bus voltage drops.

Overvoltage stall gain, used to adjust the inverter's ability to suppress overvoltage during deceleration. The larger the value, the stronger the overvoltage suppression capability. Under the premise of no overvoltage, the smaller the gain setting, the better.

For loads with small inertia, the overvoltage stall gain should be small, otherwise the dynamic response of the system will be slowed down. For loads with large inertia, this value should be large, otherwise the suppression effect will not be good, and an overvoltage fault may occur.

When the overvoltage stall gain is set to 0, the overvoltage stall function is canceled.

Function code	Name	Description (setting range)	Factory Default	Change
P9-05	VF Overcurrent Stall Protection Gain	0~100	20	☆
P9-06	VF Overcurrent Stall Protection Current	50%~200%	150%	★
P9-07	VF field weakening area current stall protection factor	50%~200%	100%	★

**Over-current stall:** when the output current of the inverter reaches the set over-current stall protection current (P9-06), the inverter will stop accelerating when it is accelerating; when it is running at a constant speed, the output frequency will be reduced; Slow down the falling speed until the current is less than the overcurrent stall protection current (P9-06), the running frequency will return to normal. See Figure 5-21 for details.

**Overcurrent Stall Protection Current:** Select the current protection point of the overcurrent stall function. When this parameter value is exceeded, the inverter starts to execute the overcurrent stall protection function. The value is a percentage relative to the rated current of the drive.

**Overcurrent stall gain:** used to adjust the inverter's ability to suppress overcurrent during acceleration and deceleration. The larger the value, the stronger the overcurrent suppression capability. Under the premise of no overcurrent, the smaller the gain setting, the better.

For loads with small inertia, the over-current stall gain should be small, otherwise the dynamic response of the system will be slowed down. For loads with large inertia, this value should be large, otherwise the suppression effect will be poor and overcurrent faults may occur. In the case of very small inertia, it is recommended to set the overcurrent suppression gain to less than 20.

When the overcurrent stall gain is set to 0, the overcurrent stall function is canceled.

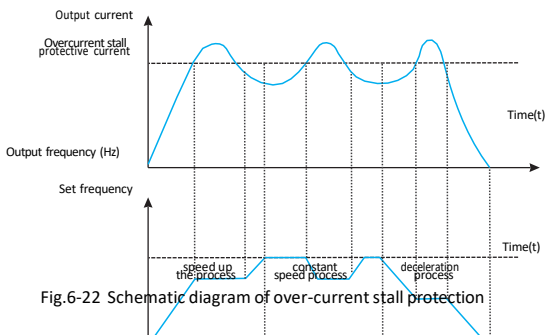

Fig.6-22 Schematic diagram of over-current stall protection

Function code	Name	Description (setting range)	Factory Default	Change
P9-08	Overvoltage stall allowable rise limit value	0.0%~50.0%	10.0%	☆

The maximum allowable adjustment amount when adjusting the frequency when overvoltage stalls, generally does not need to be modified.

Function code	Name	Description (setting range)	Factory Default	Change
P9-11	Fault automatic reset times	0~20	0	☆
P9-12	Fault relay action selection during automatic fault reset	0~1	0	☆

After selecting the automatic fault reset function of the inverter, during the execution of fault reset, it can be determined whether the fault relay action is required to shield the fault alarm caused by this parameter setting, so that the equipment can continue to run.

Function code	Name	Description (setting range)	Factory Default	Change
P9-13	Fault automatic reset interval time	0.1s~100.0s	1.0s	☆

## Chapter 6 Description of Function Codes

The waiting time between the fault alarm and the automatic reset of the fault.

Function code	Name	Description (setting range)	Factory Default	Change
P9-14	Input phase loss enable selection	0~1	1	☆

0: Disable.

1: Enable, the fault code is Err23 when input phase loss occurs.

Function code	Name	Description (setting range)	Factory Default	Change
P9-15	Output phase loss enable selection	0.0%~50.0%	10.0%	☆

0: Disable.

1: Enable, the fault code is Err24 when output phase loss occurs.

Function code	Name	Description (setting range)	Factory Default	Change
P9-16	Power-on to ground short-circuit protection selection	0.0%~50.0%	10.0%	☆

0: Disable.

1: Enable, allow the inverter to detect whether the motor is short-circuited to ground when powered on, if this fault occurs, the fault code Err20.

Function code	Name	Description (setting range)	Factory Default	Change
P9-17	Undervoltage fault automatic reset selection	0.0%~50.0%	10.0%	☆

0: Manual reset, after an undervoltage fault occurs, even if the current bus voltage returns to normal, the fault still exists, and the undervoltage fault Err12 needs to be cleared manually. 1: Automatic reset, after an undervoltage fault occurs, the inverter will follow the current bus voltage to clear the undervoltage fault Err12 by itself.

Function code	Name	Description (setting range)	Factory Default	Change
P9-18	Overvoltage suppression mode selection	0~2	1	★

0: invalid

1: Overvoltage suppression mode 1, which is mainly used to prevent the overvoltage fault from being reported due to the rise of the bus voltage caused by the energy feedback when the motor decelerates;

2: Overvoltage suppression mode 2, mainly used in situations where the load center of gravity deviates from the physical center, resulting in overvoltage caused by the rise of the bus voltage due to the energy feedback of the load itself during constant speed operation.

Function code	Name	Description (setting range)	Factory Default	Change
P9-19	Overvoltage suppression mode 2 limit value	0~2	2	★

0: invalid

**1: The constant speed and deceleration process are valid during running**

**2: Only the deceleration process is valid**

Generally used in occasions where quick shutdown is required, magnetic flux braking consumes the feedback energy brought by deceleration at the motor end, thereby effectively preventing overvoltage faults. The strength of the suppression effect can be adjusted by adjusting the magnetic flux braking gain P2-10 (VF).

When the braking resistor is used as overvoltage suppression, please set P9-19 to 0 (invalid), otherwise an abnormality may occur during deceleration.

Function code	Name	Description (setting range)	Factory Default	Change
P9-20	Overvoltage suppression mode 2 limit value	1.0%~150.0%	10.00%	★

The maximum allowable adjustment when overvoltage suppression mode 2 is in effect. The smaller the value, the smaller the rise of the bus voltage, but the longer the deceleration time.

Function code	Name	Description (setting range)	Factory Default	Change
P9-22	Fault protection action 1	0~22202	00000	☆

The meaning of each setting is the same as that of the ones.

**Units place: Motor overload - Err14 :**

0: Free parking;

## Chapter 6 Description of Function Codes

1: stop according to the stop mode; 2: keep running.

**Ten: reserved :**

Hundreds place: input phase loss - Err23; Thousands place: output phase loss - Err24;

Ten thousand: Parameter read and write exception - Err25.

Function code	Name	Description (setting range)	Factory Default	Change
P9-23	Fault protection action 2	0~22222	00000	☆

For the meaning of each setting of fault protection action 2, refer to fault protection action 1. Ones place: Communication failure - Err27;

0: Free parking;

1: stop according to the stop mode; 2: keep running.

Tens place: External fault - Err28;

Hundreds place: excessive speed deviation fault - Err29; Thousands: User-defined fault 1- Err30;

Ten thousand: user-defined fault 2- Err31.

Function code	Name	Description (setting range)	Factory Default	Change
P9-24	Fault protection action 3	0~22222	00000	☆

For the meaning of each setting of fault protection action 3, refer to fault protection action 1. Ones place: PID feedback lost during runtime - Err32;

0: Free parking;

1: stop according to the stop mode; 2: keep running;

Tens place: load loss fault - Err34; Hundreds: reserved ;

Thousands place: The current time of continuous operation is reached - Err39 ; Ten thousand: Cumulative running time reaches - Err40 ;

**Note:**

When the fault protection action 1~fault protection action 3 are selected as "free stop", the inverter will display Err\*\* and stop directly.

When "stop by stop mode" is selected: the inverter displays Ala\*\*, and stops by stop mode, and displays Err\*\* after stop.

When "continue running" is selected: the inverter continues to run and displays Ala\*\*, and the running frequency is set by P9-26.

Function code	Name	Description (setting range)	Factory Default	Change
P9-26	Continue to run frequency selection in case of failure	0~4	1	☆

0: run at the current operating frequency; 1: run at the set frequency;  
 2: run at the upper limit frequency; 3: Run at the lower frequency limit;  
 4: Run at the standby frequency setting value P9-27.

Function code	Name	Description (setting range)	Factory Default	Change
P9-27	Abnormal standby frequency set value	0.0%~100.0%	100%	☆

This value is a percentage relative to the maximum frequency, which takes effect when P9- 26 selects an abnormal backup frequency and a fault occurs.

Function code	Name	Description (setting range)	Factory Default	Change
P9-28	Drop load protection option	0~1	0	☆
P9-29	Drop load detection level	0.0%~80.0%	20.0%	★
P9-30	Load drop detection time	0.0s~100.0s	5.0s	☆

When the load loss protection is enabled, that is, P9-28=1, if the output current of the inverter is less than the load loss detection level set by P9-29 (P9-29\*motor rated current), and the duration exceeds the limit of P9-30 When the load loss detection time is reached, the inverter outputs the load loss fault Err34. Of course, it is also possible to select the action state after the load is dropped through P9-24.

Function code	Name	Description (setting range)	Factory Default	Change
P9-31	Excessive speed deviation detection value	0.0%~100.0%	20.0%	☆
P9-32	Excessive speed deviation detection time	0.0s~100.0s	0.0s	☆

## Chapter 6 Description of Function Codes

This function is only valid in vector and non-torque control mode, 100% of P9-31 corresponds to the maximum frequency P0-14.

When the inverter detects that the actual speed of the motor deviates from the set speed, the speed deviation value is greater than the excessive speed deviation detection value P9-31, and the duration is longer than the excessive speed deviation detection time P9-32, the inverter reports Err29. P9-23 can also define the inverter action state after the fault.

Function code	Name	Description (setting range)	Factory Default	Change
P9-33	Overspeed detection value	0.0%~100.0%	20.0%	☆
P9-34	Overspeed detection time	0.0s~100.0s	2.0s	☆

This function is only valid in vector and non-torque control mode, 100% of P9-34 corresponds to the maximum frequency P0-14.

When the inverter detects that the actual speed of the motor exceeds the maximum speed of the inverter, the excess value is greater than the over-speed detection value P9-33, and the duration is longer than the over-speed detection time P9-34, the inverter reports Err43 fault.

When the over-speed detection time is 0.0s, the over-speed protection is invalid.

Function code	Name	Description (setting range)	Factory Default	Change
p9-35	Motor overload protection current coefficient	100%~200%	100%	☆

This parameter is used to realize the overload protection below 110% of the rated current of the motor, and should be used in conjunction with P9-00~P9-02.

Function code	Name	Description (setting range)	Factory Default	Change
p9-36	Motor overheating pre-alarm threshold	0~200°C	80°C	☆
p9-37	Motor overheating protection value	0~200°C	100°C	☆
p9-38	Temperature sensor type selection	0~2	0	☆

I01 expansion card supports 1-way temperature detection to protect the motor from overheating, P9-38 selects the temperature sensor type.

## Group PA: PID function

PID control is a common method of process control. By performing proportional, integral and differential operations on the difference between the feedback signal of the controlled variable and the target signal, and by adjusting the output frequency of the inverter, a closed-loop system is formed, so that the controlled variable is stable at target value.

It is suitable for process control occasions such as flow control, pressure control and temperature control. Figure 5-23 is the control principle block diagram of process PID.

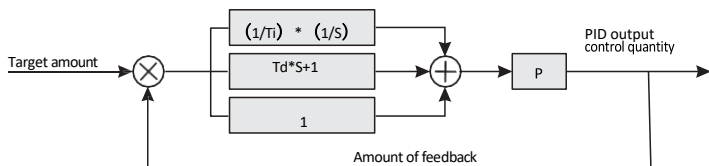

Fig.6-26 Process PID block diagram

Function code	Name	Description (setting range)	Factory Default	Change
PA-00	PID setting source	0~5	0	☆

0: PA-01 setting;

1: AI1;

2: AI2;

3: Communication given;

4: PULSE pulse given;

5: Multi-segment instructions;

6: Up/Down modify PA-01 (valid when P0-06=6).

When the frequency source selects PID, that is, P0-06 or P0-07 is selected as 6, this group of functions will work.

This parameter determines the target quantity given channel of the process PID.

The set target value of the process PID is a relative value, and the setting range is 0~100%.

The range of PID (PA-05) is not necessary, because no matter how much the range is set to, the system is based on the relative value (0~100%). However, if the PID range is set, the actual value of the signal corresponding to the PID given and feedback can be observed intuitively through the keyboard display parameters.

## Chapter 6 Description of Function Codes

Function code	Name	Description (setting range)	Factory Default	Change
PA-01	PID digital setting	0.0~100.0%	50.0%	☆

When PA-00=0 is selected, the target source is given by the keyboard. This parameter needs to be set.

Function code	Name	Description (setting range)	Factory Default	Change
PA-02	PID given change time	0.00s~650.00s	0.00s	☆

The PID given change time refers to the time required for the actual PID value to change from 0.0% to 100.0%.

When the PID given changes, the actual value of the PID given will not respond immediately. Instead, it changes linearly according to the given time, preventing the given mutation from occurring.

Function code	Name	Description (setting range)	Factory Default	Change
PA-03	PID feedback source	0~7	0	☆

0: AI1

1: AI2

2: AI1-AI2

3: Communication given 4:

PULSE pulse given 5:

AI1+AI2

6: MAX(|AI1|,|AI2|)

7: MIN(|AI1|,|AI2|)

This parameter is used to select the feedback signal channel for the process PID.

The feedback amount of the process PID is also a relative value, and the setting range is 0.0% to 100.0%.

Function code	Name	Description (setting range)	Factory Default	Change
PA-04	PID action direction	0~1	0	☆

0: Positive action, when the feedback signal of the PID is less than the given value, the output frequency of the inverter increases. Such as winding tension control occasions.

1: Reverse action, when the feedback signal of the PID is less than the given amount, the output frequency of the inverter will decrease. Such as unwinding tension control occasions.

This function is affected by the reversal of the PID action direction of the multi-function terminal (function 35), and needs to be paid attention to during use.

Function code	Name	Description (setting range)	Factory Default	Change
PA-05	PID setting feedback range	0~65535	1000	☆

PID given feedback range is a dimensionless unit, used for PID given display U1-10 and PID feedback display U1-11.

The relative value of the given feedback of PID is 100.0%, corresponding to the given feedback range PA-05. For example, if PA-05 is set to 4000, when the PID setting is 60.0%, the PID setting shows that U1-10 is 2400.

Function code	Name	Description (setting range)	Factory Default	Change
PA-06	Proportional gain P	0.0~100.0	20.0	☆
PA-07	Integral time I	0.01s~10.00s	2.00s	☆
PA-08	Differential time D	0.000s~10.000s	0.000s	☆

#### Proportional gain Kp1:

Determines the adjustment strength of the entire PID regulator, the greater the Kp1, the greater the adjustment strength. The parameter 100.0 means that when the deviation between the PID feedback amount and the given amount is 100.0%, the adjustment range of the PID regulator to the output frequency command is the maximum frequency.

#### Integration time Ti1:

Determines the strength of the PID regulator integral adjustment. The shorter the integration time, the stronger the adjustment intensity. The integral time means that when the deviation between the PID feedback quantity and the given quantity is 100.0%, the integral regulator continuously adjusts after this time, and the adjustment quantity reaches the maximum frequency.

#### Differential time Td1:

## Chapter 6 Description of Function Codes

Determines how strongly the PID regulator adjusts the deviation rate of change. The longer the differentiation time, the greater the adjustment intensity. Differential time means that when the feedback amount changes 100.0% within this time, the adjustment amount of the differential regulator is the maximum frequency.

Function code	Name	Description (setting range)	Factory Default	Change
PA-09	PID reverse cutoff frequency	0.00~Maximum frequency (P0-14)	0.00Hz	☆

In some cases, only when the PID output frequency is negative (that is, the inverter is reversed), can the PID control the given amount and the feedback amount to the same state, but too high reverse frequency is not allowed in some occasions. Yes, PA-09 is used to determine the upper limit of the reverse frequency.

Function code	Name	Description (setting range)	Factory Default	Change
PA-10	Deviation limit	0.0%~100.0%	0.0%	☆

When the deviation between the PID given amount and the feedback amount is less than PA-10, the PID will stop adjusting. In this way, when the deviation between the given and the feedback is small, the output frequency is stable and unchanged, which is very effective for some closed-loop control occasions.

Function code	Name	Description (setting range)	Factory Default	Change
PA-11	Differential clipping	0.00%~100.00%	0.0%	☆

In the PID regulator, the role of differential is more sensitive, and it is easy to cause system oscillation. For this reason, the role of PID differential is generally limited to a small range. PA-11 is used to set the range of PID differential output.

Function code	Name	Description (setting range)	Factory Default	Change
PA-12	PID feedback filter time	0.00~60.00s	0.00s	☆

PA-12 is used to filter the PID feedback amount, which is beneficial to reduce the influence of the feedback amount by interference, but it will bring the response performance of the process closed-loop system.

Function code	Name	Description (setting range)	Factory Default	Change
PA-13	PID feedback loss detection value	0.00~60.00s	0.00s	☆
PA-14	PID feedback loss detection time	0.0s~3600.0s	0s	☆

This function code is used to judge whether the PID feedback is lost.

When the PID feedback amount is less than the feedback loss detection value PA-13, and the duration exceeds the PID feedback loss detection time PA-14, the inverter will perform protection according to the one-digit selection of P9-24, and report ERR32 for faults and ALA32 for alarms.

Function code	Name	Description (setting range)	Factory Default	Change
PA-19	Integration time I2	0.01s~10.00s	2.00s	☆
PA-20	Differential time D2	0.000s~10.000s	0.000s	☆
PA-21	PID parameter switching conditions	0~2	0	☆
PA-22	PID parameter switching deviation 1	0.0%~PA-23	20.0%	☆
PA-23	PID parameter switching deviation 2	PA-22~100.0%	80.0%	☆

In some applications, a set of PID parameters cannot meet the needs of the entire operation process, and different PID parameters need to be used in different situations. This group of function codes is used for switching between two groups of PID parameters. Among them, the setting method of the regulator parameters PA-18~PA-20 is similar to the parameters PA-06~PA-08. PA-21 is the PID parameter switching condition:

PA-21=0: do not switch, use the first group of PID parameters.

PA-21=1: DI terminal switching, multi-function terminal function selection should be set to 43 (PID parameter switching terminal), when the terminal is invalid, select parameter group 1 (PA-06~PA-08), when the terminal is valid, select the parameter Group 2 (PA-18~PA-20).

PA-21=2 Automatically switch according to the deviation. When the absolute value of the deviation between the reference and the feedback is less than the PID parameter switching deviation 1 (PA-22), the PID parameter selects parameter group 1. When the absolute value of deviation between reference and feedback is greater than PID switching deviation 2 (PA- 23), PID parameter selection selects parameter group 2. When the deviation between reference and feedback is between switching deviation 1 and switching deviation 2, the PID parameters are the linear interpolation values of two sets of PID parameters, as shown in Figure 6-24.

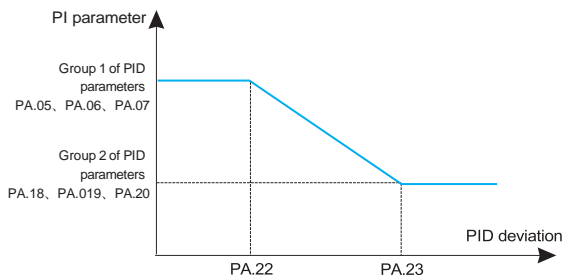

Fig.6-24 PID parameter switching

Function code	Name	Description (setting range)	Factory Default	Change
PA-24	PID initial value	0.0%~100.0%	0.0%	☆
PA-25	PID initial value hold time	0.00s~650.00s	0.00s	☆

When the inverter starts, the PID output is fixed at the PID initial value PA-24, and the PID starts the closed-loop adjustment operation after the PID initial value holding time PA-25. Figure 6-25 is a functional schematic diagram of PID initial value.

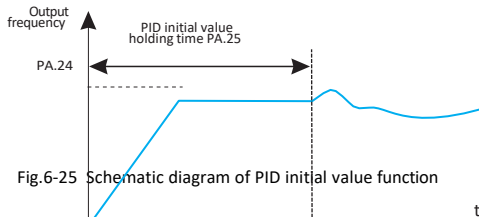

Fig.6-25 Schematic diagram of PID initial value function

Function code	Name	Description (setting range)	Factory Default	Change
PA-26	Twice output deviation positive maximum value	0.00%~100.00%	1.00%	☆
PA-27	Twice output deviation reverse maximum value	0.00%~100.00%	1.00%	☆

This function is used to limit the difference between the two outputs of the PID, so as to suppress the rapid change of the PID output and stabilize the operation of the inverter. PA-26 and PA-27 correspond respectively, the maximum value of the absolute value of the output deviation during forward rotation and reverse rotation.

Function code	Name	Description (setting range)	Factory Default	Change
PA-28	PID integral properties	00~11	00	☆

Ones place: integral separation selection 0: invalid

1: Valid

If the integral separation is set to be valid, when the multi-function digital DI integral pause (function 38) is valid, the integral PID integral of the PID stops the operation, and only the proportional and differential functions of the PID are valid at this time.

When the integral separation selection is invalid, regardless of whether the multi-function digital DI is valid or not, the integral separation is invalid.

Tens place: whether to stop the integration selection after the output reaches the limit value 0: Continue points

1: Stop integration

After the PID operation output reaches the maximum or minimum value, you can choose whether to stop the integral action. If you choose to stop integration, the PID integration will stop calculating at this time, which can reduce the overshoot of the PID.

Function code	Name	Description (setting range)	Factory Default	Change
PA-29	PID shutdown operation	0~1	0	☆

0: In stop state, PID does not operate. 1: In stop state, PID operation.

## Group Pb: Swing Frequency, Fixed Length and Count

The swing frequency function is suitable for textile, chemical fiber and other industries, as well as occasions where traversing and winding functions are required.

The swing frequency function refers to the output frequency of the inverter, which swings up and down with the set frequency as the center. The trajectory of the running frequency on the time axis is shown in Figure 6-26. The swing amplitude is set by Pb-00 and Pb-01. When Pb-01 is set to 0, the swing is 0, and the swing frequency does not work.

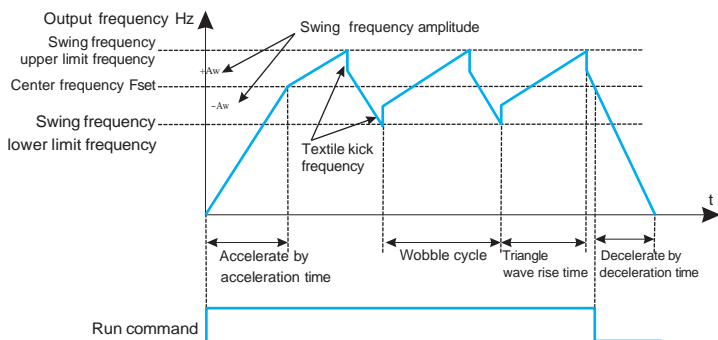

Figure 6-26. Schematic diagram of swing frequency operation

Function code	Name	Description (setting range)	Factory Default	Change
Pb-00	Swing setting method	0~1	0	☆

Use this parameter to determine the reference amount of the swing.

0: Relative center frequency (P0-06 frequency source), which is a variable swing system. The swing varies with the center frequency (set frequency).

1: Relative to the maximum frequency (P0-14), it is a fixed swing system, and the swing is fixed.

Function code	Name	Description (setting range)	Factory Default	Change
Pb-01	Swing frequency amplitude	0.0%~100.0%	0.0%	☆
Pb-02	Jump frequency amplitude	0.0%~50.0%	0.0%	☆

Use this parameter to determine the swing frequency amplitude and the value of the sudden jump frequency.

When setting the swing amplitude relative to the center frequency (Pb-00=0), swing amplitude  $AW =$  frequency source P0-07  $\times$  swing amplitude Pb-01. When setting the swing amplitude relative to the maximum frequency (Pb-00=1), the swing amplitude  $AW =$  the maximum frequency P0-14  $\times$  the swing amplitude Pb-01.

The kick frequency amplitude is the percentage of the kick frequency relative to the swing amplitude when the swing frequency is running, namely: kick frequency = swing amplitude  $AW \times$  kick frequency amplitude Pb-02. If the swing is selected relative to the center frequency (Pb-00=0), the kick frequency is the change value. If the swing is selected relative to the maximum frequency (Pb-00=1), the kick frequency is a fixed value.

The wobble operating frequency is constrained by the upper limit frequency and the lower limit frequency.

Function code	Name	Description (setting range)	Factory Default	Change
Pb-03	Swing frequency cycle	0.1s~3000.0s	10.0s	☆
Pb-04	Triangular wave rising time coefficient	0.1%~100.0%	50.0%	☆

Wobble Period: The time value of a complete Wobble period.

The triangular wave rising time coefficient Pb-04 is the time percentage of the triangular wave rising time relative to the wobble frequency period Pb-03.

Triangular wave rise time = swing frequency period Pb-03  $\times$  triangular wave rise time coefficient Pb-04, the unit is second.

Triangular wave falling time = swing frequency period Pb-03  $\times$  (1-triangular wave rising time coefficient Pb-04), the unit is second.

Function code	Name	Description (setting range)	Factory Default	Change
Pb-05	Set length	0m~65535m	1000m	☆
Pb-06	Actual length	0m~65535m	0m	☆
Pb-07	Number of pulses per meter	0.1~6553.5	100.0	☆

The above function codes are used for fixed-length control.

The length information needs to be collected through the multi-function digital input terminal.

The number of pulses sampled by the terminal is divided by the number of pulses per meter Pb-07, and the actual length Pb-06 can be calculated. When the actual length is greater than or equal to the set length Pb-05, the multi-function digital terminal will output the "length reached" ON signal.

During the fixed-length control process, the length reset operation can be performed through the multi-function DI terminal (the DI function selection is 31). For details, please refer to the settings of P5-00~P5-04.

In the application, the corresponding input terminal function needs to be set to "length count input" (the DI function is selected as 30). When the pulse frequency is high, the HDI port must be used.

Function code	Name	Description (setting range)	Factory Default	Change
Pb-08	Set count value	1~65535	1000	☆
Pb-09	Designated count value	1~65535	1000	☆

The count value needs to be collected through the multi-function digital input terminal. In the application, the corresponding input terminal function needs to be set to "counter input" (function 28). When the pulse frequency is high, the DI5 port must be used.

When the count value reaches the set count value Pb-08, the multi-function digital output "set count value reached" ON signal.

When the count value reaches the designated count value Pb-09, the multi-function digital output "designated count value reached" ON signal.

The specified count value Pb-09 should not be greater than the set count value Pb-08. Figure 6-26 is a schematic diagram of the function of setting count value arrival and specifying count value arrival.

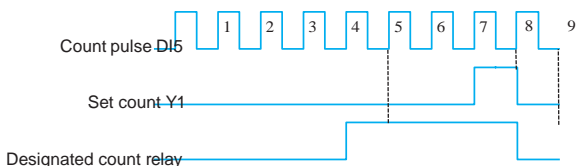

Fig.6-27 Reaching the set count value and designated count value

## Group PC: Multi-segment instruction and simple PLC function

The simple PLC function is that the inverter has a built-in programmable logic controller (PLC) to complete the automatic control of multi-segment frequency logic. The running time, running direction and running frequency can be set to meet the requirements of the process.

KD600 series intelligent inverter can realize 16-stage speed change control, and there are 4 kinds of acceleration and deceleration time for selection.

When the set PLC completes a cycle, the multi-function digital output terminal Y1, multi-function relays RELAY1 and RELAY2 can output ON signal. For details, see P6-00~P6-02.

Function code	Name	Description (setting range)	Factory Default	Change
PC-00	Multi-speed 0	-100.0%~100.0%	0.0%	☆
PC-01	Multi-speed 1	-100.0%~100.0%	0.0%	☆
PC-02	Multi-speed 2	-100.0%~100.0%	0.0%	☆
PC-03	Multi-speed 3	-100.0%~100.0%	0.0%	☆
PC-04	Multi-speed 4	-100.0%~100.0%	0.0%	☆
PC-05	Multi-speed 5	-100.0%~100.0%	0.0%	☆
PC-06	Multi-speed 6	-100.0%~100.0%	0.0%	☆
PC-07	Multi-speed 7	-100.0%~100.0%	0.0%	☆
PC-08	Multi-speed 8	-100.0%~100.0%	0.0%	☆
PC-09	Multi-speed 9	-100.0%~100.0%	0.0%	☆
PC-10	Multi-speed 10	-100.0%~100.0%	0.0%	☆
PC-11	Multi-speed 11	-100.0%~100.0%	0.0%	☆
PC-12	Multi-speed 12	-100.0%~100.0%	0.0%	☆
PC-13	Multi-speed 13	-100.0%~100.0%	0.0%	☆
PC-14	Multi-speed 14	-100.0%~100.0%	0.0%	☆
PC-15	Multi-speed 15	-100.0%~100.0%	0.0%	☆

When the frequency source selection P0-06, P0-07, P0-10 is determined as the multi-speed running mode, it is necessary to set PC-00~PC-15 to determine its characteristics.

Description: The symbols of PC-00~PC-15 determine the running direction of simple PLC. If it is a negative value, it means running in the opposite direction.

Simple PLC schematic diagram:

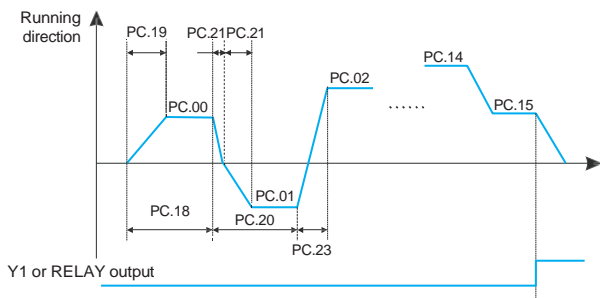

Fig. 6-28 Simple PLC schematic diagram

Function code	Name	Description (setting range)	Factory Default	Change
PC-16	PLC operation mode	0~2	0	☆

The simple PLC function has two functions: as a frequency source or as a voltage for VF separation.

Figure 6-29 is a schematic diagram of a simple PLC as the frequency source. When the simple PLC is used as the frequency source, the positive and negative values of PC-00~PC-15 determine the running direction. If it is negative, it means that the inverter runs in the opposite direction.

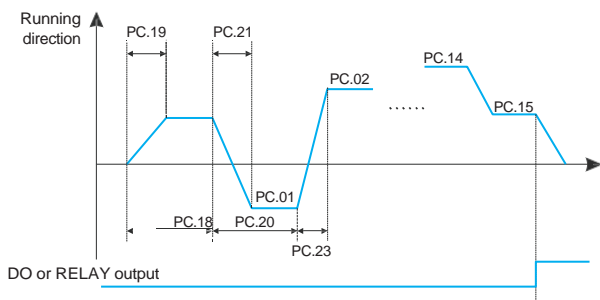

Fig. 6-29 Simple PLC schematic diagram

When used as a frequency source, PLC has three operating modes, which are not available when used as a VF separation voltage source. in:

### 0: Stop at the end of a single operation

The inverter will automatically stop after completing a single cycle, and it needs to give the running command again to start.

### 1: Keep the final value at the end of a single run

After the inverter completes a single cycle, it automatically maintains the running frequency and direction of the last segment.

### 2: Keep looping

After the inverter completes one cycle, it will automatically start the next cycle until it stops when there is a stop command.

Function code	Name	Description (setting range)	Factory Default	Change
PC-17	PLC power-down memory selection	0~3	0	☆

This function code determines the memory mode of the inverter when the inverter is powered off when the PLC is running.

0: No memory when power off and no memory when stopped; 1:

Memory when power off and no memory when stopped;

2: No memory when power off and memory when shut down; 3:

Power-down memory and shutdown memory.

PLC power-off memory refers to the memory of the PLC's operating stage and operating frequency before power-off, and continues to run from the memory stage when the power is next turned on. If you choose not to remember, the PLC process will be restarted every time the power is turned on.

PLC shutdown memory is to record the previous PLC running stage and running frequency when it stops, and continue to run from the memory stage in the next running. If you choose not to remember, the PLC process will be restarted each time it is started.

Function code	Name	Description (setting range)	Factory Default	Change
PC-18	Running time of simple PLC multi-speed 0	0.0s(h)~6500.0s(h)	0.0s(h)	☆

## Chapter 6 Description of Function Codes

Function code	Name	Description (setting range)	Factory Default	Change
PC-19	Acceleration/deceleration time of simple PLC multi-speed 0	0~3	0	☆
PC-20	Running time of simple PLC multi-speed 1	0.0s(h)~6500.0s(h)	0.0s(h)	☆
PC-21	Acceleration/deceleration time of simple PLC multi-speed 1	0~3	0	☆
PC-22	Running time of simple PLC multi-speed 2	0.0s(h)~6500.0s(h)	0.0s(h)	☆
PC-23	Acceleration/deceleration time of simple PLC multi-speed 2	0~3	0	☆
PC-24	Running time of simple PLC multi-speed 3	0.0s(h)~6500.0s(h)	0.0s(h)	☆
PC-25	Acceleration/deceleration time of simple PLC multi-speed 3	0~3	0	☆
PC-26	Running time of simple PLC multi-speed 4	0.0s(h)~6500.0s(h)	0.0s(h)	☆
PC-27	Acceleration/deceleration time of simple PLC multi-speed 4	0~3	0	☆
PC-28	Running time of simple PLC multi-speed 5	0.0s(h)~6500.0s(h)	0.0s(h)	☆
PC-29	Acceleration/deceleration time of simple PLC multi-speed 5	0~3	0	☆
PC-30	Running time of simple PLC multi-speed 6	0.0s(h)~6500.0s(h)	0.0s(h)	☆
PC-31	Acceleration/deceleration time of simple PLC multi-speed 6	0~3	0	☆
PC-32	Running time of simple PLC multi-speed 7	0.0s(h)~6500.0s(h)	0.0s(h)	☆
PC-33	Acceleration/deceleration time of simple PLC multi-speed 7	0~3	0	☆
PC-34	Running time of simple PLC multi-speed 8	0.0s(h)~6500.0s(h)	0.0s(h)	☆
PC-35	Acceleration/deceleration time of simple PLC multi-speed 8	0~3	0	☆
PC-36	Running time of simple PLC multi-speed 9	0.0s(h)~6500.0s(h)	0.0s(h)	☆
PC-37	Acceleration/deceleration time of simple PLC multi-speed 9	0~3	0	☆

Function code	Name	Description (setting range)	Factory Default	Change
PC-38	Running time of simple PLC multi-speed 10	0.0s(h)~6500.0s(h)	0.0s(h)	☆
PC-39	Acceleration/deceleration time of simple PLC multi-speed 10	0~3	0	☆
PC-40	Running time of simple PLC multi-speed 11	0.0s(h)~6500.0s(h)	0.0s(h)	☆
PC-41	Acceleration/deceleration time of simple PLC multi-speed 11	0~3	0	☆
PC-42	Running time of simple PLC multi-speed 12	0.0s(h)~6500.0s(h)	0.0s(h)	☆
PC-43	Acceleration/deceleration time of simple PLC multi-speed 12	0~3	0	☆
PC-44	Acceleration/deceleration time of simple PLC multi-speed 13	0~3	0	☆
PC-45	Running time of simple PLC multi-speed 14	0.0s(h)~6500.0s(h)	0.0s(h)	☆
PC-46	Acceleration/deceleration time of simple PLC multi-speed 14	0~3	0	☆
PC-47	Running time of simple PLC multi-speed 15	0.0s(h)~6500.0s(h)	0.0s(h)	☆
PC-48	Acceleration/deceleration time of simple PLC multi-speed 15	0~3	0	☆
PC-49	Running time of simple PLC multi-speed 15	0.0s(h)~6500.0s(h)	0.0s(h)	☆
PC-50	Time unit of multi-speed	0~1	0	☆

Define the running time of each segment of the 16-segment program and the selection of acceleration speed of each segment. Among them, the selection of acceleration and deceleration time 0~3 respectively represents the acceleration and deceleration time 0: P0-23, P0-24; acceleration and deceleration time 1: P7-03, P7-04; Deceleration time 3: P7-07, P7-08.

PC-50 defines the unit of each run time of the PLC.

**0: seconds;**

**1 hour.**

Function code	Name	Description (setting range)	Factory Default	Change
PC-51	Multi-speed priority mode selection	0~1	1	☆

## Chapter 6 Description of Function Codes

Multi-speed priority means that when the multi-speed terminals are not all 0, the multi-speed command value is given priority.

0: Multi-speed does not have priority; 1:

Multi-speed priority.

Function code	Name	Description (setting range)	Factory Default	Change
PC-52	Multi-speed priority acceleration and deceleration time selection	0~3	0	☆

In the case of multi-speed priority, select the acceleration and deceleration mode when executing multi-speed.

0 to 3 respectively represent acceleration and deceleration time 1 to acceleration and deceleration time 4.

Function code	Name	Description (setting range)	Factory Default	Change
PC-53	Multi-speed PC-00~PC-15 unit selection	0~1	0	☆

It is used to select the unit of multi-stage speed PC-00~PC-15 to meet the needs of multi-stage speed frequency unit in different occasions.

Function code	Name	Description (setting range)	Factory Default	Change
PC-53	Multi-segment instruction 0 given mode	0~5	0	☆

This parameter determines the given channel of multi-segment instruction 0. In addition to PC-00, there are many other options for multi-segment instruction 0, which is convenient to switch between multi-segment instruction and other given methods. When the multi-segment instruction is used as the frequency source or the simple PLC is used as the frequency source, the switching of the two frequency sources can be easily realized.

0: Function code PC-00 given; 1:

A11 given;

2: AI2 given;

3: PULSE pulse;

4: PID;

5: Preset frequency given (P0-11), UP/DOWN can be modified.

## Group PD: Torque control

Torque control can be performed only when the control mode P0-03 is vector control, so that the output torque of the motor is controlled by the torque command. When using torque control, there are the following precautions:

### Torque control takes effect

To make torque control effective, please set Pd-10 to 1, or set the multi-function DI terminal function to 44 before use.

In addition, the torque control prohibition (function 32) can be realized through the multi-function digital DI terminal. When the torque prohibition function is valid, the inverter is fixed in the speed control mode.

### Setting of torque command and speed limit

The torque command can be set through Pd-00 and Pd-01. When the torque source is non-digital setting, 100% input corresponds to the setting value of Pd-01.

The speed limit can be set digitally through Pd-03 and Pd-04, or through the upper limit frequency P0-15, P0-16, P0-17.

### Direction setting of torque command

During torque control, the direction of the torque command is related to the direction of the running command and the input torque value, as shown in the following table:

Run command	Enter torque value (calculated percentage)	Torque command direction
Forward	>0	Forward direction
Forward	<0	Reverse direction
Reverse	>0	Forward direction
Reverse	<0	Reverse direction

### Switching between speed and torque modes

When the multi-function digital DI terminal is set with speed control/torque control switching (function 44), when the speed control/torque control switching function of the corresponding terminal is valid, the control mode is equivalent to the inversion of the value of Pd-10; otherwise the control mode is determined by Pd-10.

Function code	Name	Description (setting range)	Factory Default	Change
PC-52	Torque command source selection	0~6	0	★

Pd-00 is used to select the torque setting source, and there are 7 torque setting methods.

**0: Digital setting (Pd-01), which means that the target torque directly uses the setting value of Pd-01.**

**1: AI1**

**2: AI2**

It means that the target torque is determined by the analog input terminal. The KD600 control board provides 2 analog input terminals (AI1, AI2), of which AI1 is 0V~10V voltage input, AI2 can be 0V~10V voltage input, or 0mA~20mA current input, which is selected by the DIP switch on the control board. The input voltage value of AI1, AI2, and the corresponding relationship curve of the target torque, the user can freely choose through P5-45.

KD600 provides 4 sets of corresponding relationship curves, of which 2 sets of curves are straight-line relationships (2-point correspondence), and 2 sets of curves are arbitrary curves with 4-point correspondences. code to set.

Function code P5-45 is used to set the two analog inputs of AI1~AI2, and select which group of the 4 groups of curves respectively.

When AI is used as torque reference, the voltage/current input corresponds to 100.0% of the setting, which refers to the percentage of the relative torque digital setting PD-01.

**3: Communication given**

It means that the target torque is given by the communication method. The data is given by the host computer through the communication address 0x1000, the data format is -100.00%

~ 100.00%, and 100.00% refers to the percentage of the relative torque digital setting PD-01.

**4: PULSE pulse (HDI)**

The target torque is given by the terminal HDI high-speed pulse.

Pulse given signal specifications: voltage range 9V ~ 30V, frequency range 0kHz ~ 50kHz. Pulse given can only be input from the multi-function input terminal HDI.

The relationship between the input pulse frequency of the HDI terminal and the corresponding setting is set through P5-30~P5-34. The corresponding relationship is a straight line corresponding relationship between 2 points. The 100.0% set corresponding to the pulse input refers to the relative torque figure. Set the percentage of PD-01.

**5: MIN (AI1, AI2)**

It means that the target torque is given by the minimum value of the analog quantities AI1 and AI2.

It means that the target torque is given by the maximum value of the analog quantities AI1 and AI2. Options 1 to 6 correspond to full scale (Pd-01).

Function code	Name	Description (setting range)	Factory Default	Change
PD-01	Torque digital given	-200.0%~200.0%	150.0%	☆

The torque setting adopts relative value, 100.0% corresponds to the rated torque of the motor. The setting range is -200% to 200%, indicating that the maximum torque of the inverter is twice the rated torque of the motor. When the motor power is greater than that of the inverter, it will be limited to the maximum torque of the inverter.

Function code	Name	Description (setting range)	Factory Default	Change
PD-03	Torque control positive direction maximum frequency	0.00Hz~Maximum frequency (PO-14)	50.00Hz	☆
PD-04	Torque control reverse direction maximum frequency	0.00Hz~Maximum frequency (PO-14)	50.00Hz	☆

It is used to set the forward or reverse maximum running frequency of the inverter in torque control mode.

During torque control of the inverter, if the load torque is less than the output torque of the motor, the motor speed will continue to rise. In order to prevent accidents such as flying in the mechanical system, the maximum speed of the motor during torque control must be limited.

Function code	Name	Description (setting range)	Factory Default	Change
PD-06	Torque command filter time	0.00s~10.00s	0.00s	☆

Setting this parameter value can make the torque command smoother and the control more compliant, but the response will be slower accordingly.

Function code	Name	Description (setting range)	Factory Default	Change
PD-07	Torque mode frequency acceleration time	0.0s~1000.0s	10.0s	☆

## Chapter 6 Description of Function Codes

Function code	Name	Description (setting range)	Factory Default	Change
PD-08	Torque mode frequency deceleration time	0.0s~1000.0s	10.0s	☆

This parameter is used to set the acceleration and deceleration time of the maximum frequency during torque control to reduce the start-up impact.

Function code	Name	Description (setting range)	Factory Default	Change
PD-10	Speed/torque mode selection	0~1	0	★

0: Speed mode;

1: Torque mode.

## Group PE: AI multi-point curve setting

Function code	Name	Description (setting range)	Factory Default	Change
PE-00	Curve 1 minimum input	-10.00V ~ PE-02	0.00V	☆
PE-01	Curve 1 minimum input corresponding setting	-100.0% ~ 100.0%	0.0%	☆
PE-02	Curve 1 Knee 1 Input	PE-00 ~ PE-04	3.00V	☆
PE-03	Curve 1 inflection point 1 input corresponding setting	-100.0% ~ 100.0%	30.0%	☆
PE-04	Curve 1 Knee 2 Input	PE-02 ~ PE-06	6.00V	☆
PE-05	Curve 1 inflection point 2 input corresponding setting	-100.0% ~ 100.0%	60.0%	☆
PE-06	Curve 1 maximum input	PE-04 ~ 10.00	10.00V	☆
PE-07	Curve 1 maximum input corresponding setting	-100.0% ~ 100.0%	100.0%	☆
PE-08	Curve 2 minimum input	-10.00 ~ PE-10	0.00V	☆
PE-09	Curve 2 minimum input corresponding setting	-100.0% ~ 100.0%	0.0%	☆
PE-10	Curve 2 Knee 1 Input	PE-08 ~ PE-12	3.00V	☆
PE-11	Curve 2 inflection point 1 input corresponding setting	-100.0% ~ 100.0%	30.0%	☆
PE-12	Curve 2 Knee 2 Input	PE-10 ~ PE-14	6.00V	☆
PE-13	Curve 2 inflection point 2 input corresponding setting	-100.0% ~ 100.0%	60.0%	☆
PE-14	Curve 2 maximum input	PE-12 ~ 10.00V	10.00V	☆
PE-15	Curve 2 maximum input corresponding setting	-100.0% ~ 100.0%	100.0%	☆

The above function code defines the relationship between the analog input voltage and the set value represented by the analog input. When the analog input voltage exceeds the set maximum input or minimum input range, the other part will be calculated as the maximum input or minimum input.

When the analog input is current input, 1mA current is equivalent to 0.5V voltage.

The curve 1 and curve 2 are the same as the analog input quantization of the P5 group, but the analog quantization of the P5 group is linear and the PE group curve can be set to the curve type, so the analog input multi-point curve can be used more flexibly. The schematic diagram is shown in Figure 6-30.

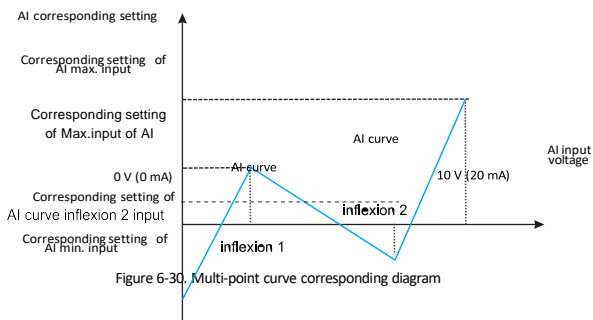

Function code	Name	Description (setting range)	Factory Default	Change
PE-24	AI1 set jump point	-100.0%~100.0%	0.0%	☆
PE-25	AI1 sets the jump range	0.0%~100.0%	0.5%	☆

The analog input AI1~AI2 of KD600 all have the function of setting value jumping.

The jump function means that when the corresponding setting of the analog quantity changes between the upper and lower intervals of the jump point, the corresponding setting value of the analog quantity is fixed to the value of the jump point.

For example: the voltage of the analog input AI1 fluctuates around 5.00V, the fluctuation range is 4.90V~5.10V, the minimum input of AI1 is 0.00V corresponds to 0.0%, and the maximum input of 10.00V corresponds to 100%, then the detected AI1 corresponds to the setting It fluctuates between 49.0% and 51.0%. Set AI1 to set jump point PE-24 to 50.0%, set AI1 to set jump amplitude PE-25 to 1.0%, then when the above AI1 input is processed by the jump function, the corresponding setting of AI1 input is fixed to 50.0%. AI1 is transformed into a stable input, eliminating fluctuations.

## Group PF: Manufacturer parameters

Manufacturer's parameter group, which cannot be changed by the user.

## Group A0: Second motor parameter setting

When the user needs to switch between two motors, the motor switch can be realized through A0-00 or the No. 41 function of the multi-function digital DI terminal. In addition, the two motors can be set with motor nameplate parameters, motor parameter tuning, VF control or vector control, and parameters related to VF control or vector control performance can be set separately.

The three groups of function codes A1, A2, and A3 correspond to the motor parameters, VF parameter settings, and vector control parameters of the second motor, respectively. All parameters of group A, their content definitions and usage methods are consistent with the relevant parameters of the first motor. Here The description will not be repeated, and the user can refer to the description of the relevant parameters of the first motor.

Function code	Name	Description (setting range)	Factory Default	Change
A0-00	Motor selection	0~1	1	★

1: Motor No. 1

2: Motor No. 2

When the current motor is No. 1, the A1~A3 function groups are not visible.

Function code	Name	Description (setting range)	Factory Default	Change
A0-01	The second motor control mode	1~2	2	★

1: Open loop vector control (speed sensorless vector); 2: VF control.

Function code	Name	Description (setting range)	Factory Default	Change
A0-02	Second motor acceleration and deceleration time selection	1~2	2	★

0: Consistent with the first motor;

1: Acceleration and deceleration time 1, P0-23, P0-24; 2:

Acceleration and deceleration time 2, P7-03, P7-04; 3:

Acceleration and deceleration time 3, P7-05, P7-06; 4:

Acceleration and deceleration time 4, P7-07, P7-08.

## Group A1: Second Motor Parameters

The detailed description of the function code parameters of this group is the same as that of the P4 group.

Function code	Name	Description (setting range)	Factory Default	Change
A1-00	Motor parameter tuning	0~2	0	★

0: no function;

1: Static tuning;

2: Dynamic full tuning.

Function code	Name	Description (setting range)	Factory Default	Change
A1-01	Motor 2 rated power	0.1Kw~1000.0Kw	Model is determined	★
A1-02	Motor 2 rated voltage	1V~1500V	380V	★
A1-03	Motor 2 Number of motor poles	2 to 64	Model is determined	●
A1-04	Motor 2 rated current	0.1A~3000.0A	A1-01 OK	★
A1-05	Motor 2 rated frequency	0.01Hz~P0-14	50.00Hz	★
A1-06	Motor 2 rated speed	1rpm~65535rpm	A1-01 OK	★
A1-07	Motor 2 no-load current	0.1A~1500.0A	A1-01 OK	★
A1-08	Motor 2 stator resistance	0.001~65.535ohm	Model is determined	★
A1-09	Motor 2 rotor resistance	0.001~65.535ohm	Model is determined	★
A1-10	Motor 2 mutual inductance	0.1mH~6553.5mH	Model is determined	★
A1-11	Motor 2 leakage inductance	0.01mH~655.35mH	Model is determined	★
A1-12	Acceleration at Dynamic Full Tuning	1.0s~6000.0s	10.0s	☆
A1-13	Deceleration at dynamic full tuning	1.0s~6000.0s	10.0s	☆

## Group A2: Second motor VF parameter setting

The detailed description of the function code parameters of this group is consistent with the P2 group. For the VF control function codes not listed in this group, the P2 group is directly used.

Function code	Name	Description (setting range)	Factory Default	Change
A2-00	Torque boost	0.0%~30.0%	0.0%	☆

When the parameter is set to 0, it means automatic torque boost.

Function code	Name	Description (setting range)	Factory Default	Change
A2-01	Oscillation suppression gain	0~100	Model is determined	☆

## Group A3: Second motor vector control parameters

The function of this group of parameters is similar to the parameters of group P3, which is valid when the motor is the second motor. For detailed function code description, please refer to the description of function code of group P3.

Function code	Name	Description (setting range)	Factory Default	Change
A3-00	Switching frequency P1	0.00Hz~A3-02	5.00Hz	☆
A3-02	Switching frequency P2	A3-00~P0-14	10.00Hz	☆
A3-04	Low frequency speed proportional gain	0.1~10.0	4.0	☆
A3-05	Low frequency speed integration time	0.01s~10.00s	0.50s	☆
A3-06	High frequency speed proportional gain	0.1~10.0	2.0	☆
A3-07	High frequency speed integration time	0.01s~10.00s	1.00s	☆
A3-08	Speed loop integral attribute selection	0~1	0	★
A3-11	Torque current regulator Kp	0~30000	2000	☆

Function code	Name	Description (setting range)	Factory Default	Change
A3-12	Torque current regulator Ki	0~30000	1300	☆
A3-13	Excitation current regulator Kp	0~30000	2000	☆
A3-14	Excitation current regulator Ki	0~30000	1300	☆
A3-15	Flux Brake Gain	0~200	0	☆
A3-16	Field weakening torque correction factor	50%~200%	100%	☆
A3-17	Slip Compensation Coefficient	50%~200%	100%	☆
A3-18	Speed loop feedback filter time constant	0.000s~1.000s	0.015s	☆
A3-19	Speed loop output filter time constant	0.000s~1.000s	0.000s	☆
A3-20	Electric torque upper limit source	0~4	0	☆
A3-21	Electric torque upper limit	0.0%~200.0%	150.0%	☆
A3-22	Braking torque upper limit source	0~4	0	☆
A3-23	Braking torque upper limit	0.0%~200.0%	150%	☆

## Group B0: System parameters

B0 is used to manage the inverter function code group, which can be set by the user as required.

Function code	Name	Description (setting range)	Factory Default	Change
B0-00	Function code read-only selection	0~1	0	☆

0: invalid

1: Except for B0-00, all function codes can only be viewed and cannot be modified, which can prevent the parameters from being misoperated

Function code	Name	Description (setting range)	Factory Default	Change
B0-01	LCD top menu display/LED second line display	0~5	0	☆

Used to select the second display variable of the LCD top-level menu during operation. The first display variable is the running frequency and cannot be changed.

- 0: output current;
- 1: Motor speed;
- 2: Load speed;
- 3: Output voltage;
- 4: PID given;
- 5: PID feedback.

Function code	Name	Description (setting range)	Factory Default	Change
B0-02	LCD language selection	0~1	0	☆

- 0: Chinese;
- 1: English.

Function code	Name	Description (setting range)	Factory Default	Change
B0-03	LED menu toggle selection	0~1	0	☆

- 0: Disable;
- 1: enable.

Function code	Name	Description (setting range)	Factory Default	Change
B0-04	Vector operating frequency display selection	0~1	0	☆

- 0: real-time frequency;
- 1: set frequency.

Function code	Name	Description (setting range)	Factory Default	Change
B0-05	Display selection during UP/Down adjustment	0~1	0	☆

- 0: Display the set value;
- 1: Display the current variable value.

## Group B1: User function code customization

KD600 inverter provides users with 31 freely definable user-customized function codes to facilitate users to view, modify parameters and operate quickly. After the user customizes the function code through group B1, enter the user menu mode -USER to view and modify the customized function code. For the entry and exit of the user menu mode, please refer to Chapter 4 <<4.4 Function Code Menu Mode and Switching Instructions>>.

Function code	Name	Description (setting range)	Factory Default	Change
B1-00	Clear custom function code selection	0~1	0	☆

0: invalid;

1: Clear user-defined function codes. After clearing, B1-01~B1-31 are all uP0.00, and at the same time, the factory custom user function code can be restored through P0-28.

Function code	Name	Description (setting range)	Factory Default	Change
B1-01	Custom function code 1	uP0-00~uU1-xx	uP0-03	☆
B1-02	Custom function code 2	uP0-00~uU1-xx	uP0-04	☆
B1-03	Custom function code 3	uP0-00~uU1-xx	uP0-06	☆
B1-04	Custom function code 4	uP0-00~uU1-xx	uP0-23	☆
B1-05	Custom function code 5	uP0-00~uU1-xx	uP0-24	☆
B1-06	Custom function code 6	uP0-00~uU1-xx	uP4-00	☆
B1-07	Custom function code 7	uP0-00~uU1-xx	uP4-01	☆
B1-08	Custom function code 8	uP0-00~uU1-xx	uP4-02	☆
B1-09	Custom function code 9	uP0-00~uU1-xx	uP4-04	☆
B1-10	Custom function code 10	uP0-00~uU1-xx	uP4-05	☆
B1-11	Custom function code 11	uP0-00~uU1-xx	uP4-06	☆
B1-12	Custom function code 12	uP0-00~uU1-xx	uP4-12	☆
B1-13	Custom function code 13	uP0-00~uU1-xx	uP4-13	☆
B1-14	Custom function code 14	uP0-00~uU1-xx	uP5-00	☆
B1-15	Custom function code 15	uP0-00~uU1-xx	uP5-01	☆

Function code	Name	Description (setting range)	Factory Default	Change
B1-16	Custom function code 16	uP0-00~uU1-xx	uP5-02	☆
B1-17	Custom function code 17	uP0-00~uU1-xx	uP6-00	☆
B1-18	Custom function code 18	uP0-00~uU1-xx	uP6-01	☆
B1-19	Custom function code 19	uP0-00~uU1-xx	uP0-00	☆
B1-20	Custom function code 20	uP0-00~uU1-xx	uP0-00	☆
B1-21	Custom function code 21	uP0-00~uU1-xx	uP0-00	☆
B1-22	Custom function code 22	uP0-00~uU1-xx	uP0-00	☆
B1-23	Custom function code 23	uP0-00~uU1-xx	uP0-00	☆
B1-24	Custom function code 24	uP0-00~uU1-xx	uP0-00	☆
B1-25	Custom function code 25	uP0-00~uU1-xx	uP0-00	☆
B1-26	Custom function code 26	uP0-00~uU1-xx	uP0-00	☆
B1-27	Custom function code 27	uP0-00~uU1-xx	uP0-00	☆
B1-28	Custom function code 28	uP0-00~uU1-xx	uP0-00	☆
B1-29	Custom function code 29	uP0-00~uU1-xx	uP0-00	☆
B1-30	Custom function code 30	uP0-00~uU1-xx	uP0-00	☆
B1-31	Custom function code 31	uP0-00~uU1-xx	uP0-00	☆

The small u in the first letter of the user-defined function code range indicates the user-defined function code, and the rest of the symbols indicate the function code.

For example, uP0-03 indicates that the customized function code is P0-03, but uP0-00 indicates that the customized function code is empty.

## Group B2: Optimize control parameters

Function code	Name	Description (setting range)	Factory Default	Change
B2-00	Dead Time Compensation Enable Selection	0~1	1	☆

0: no compensation;

1: Compensation.

Function code	Name	Description (setting range)	Factory Default	Change
B2-01	PWM method	0~1	0	☆

0: Asynchronous modulation;

1: Synchronous modulation, only valid for VF control mode, and the operating frequency is higher than 85Hz;

Synchronous modulation means that the carrier frequency of the inverter changes linearly with the output frequency, and is generally used at a higher frequency, which is beneficial to improve the quality of the output voltage. The asynchronous modulation is that the carrier frequency is constant, and the asynchronous modulation effect is better at low frequencies.

Function code	Name	Description (setting range)	Factory Default	Change
B2-02	PWM seven-segment/five-segment selection	0~1	0	☆

0: 7 segments in the whole process;

1: Seven-segment/five-segment automatic switching;

When the PWM seven-stage continuous modulation is used, the switching loss of the inverter is large, but the current ripple is small; in the 5-stage intermittent debugging mode, the switching loss is small, the current ripple is large, and the motor noise increases.

Function code	Name	Description (setting range)	Factory Default	Change
B2-03	CBC current limit enable selection	0~1	1	☆

0: Disable;

1: Enable, at this time, the overcurrent fault of the inverter can be reduced to a great extent, so as to realize uninterrupted operation. If the inverter will fault Er33 when the current is limited rapidly for a long time, it means that the inverter is overloaded and needs to stop.

Function code	Name	Description (setting range)	Factory Default	Change
B2-04	Braking point	330.0V~1200.0V	360.0V 690.0V	☆

<1> is the value of the 380V class inverter, and the value is 360.0V at the 200V class;

This value is the voltage point at which the braking resistor turns on. When there is a braking resistor and the bus voltage is greater than B2-04, the inverter will release excess braking energy through the braking resistor to prevent overvoltage of the inverter.

Function code	Name	Description (setting range)	Factory Default	Change
B2-05	Undervoltage point	150.0V~820.0V	200.0V 350.0V	☆

<1> is the value of 380V class inverter, and the value is 200.0V in 200V class;

This value is the judgment point of the inverter undervoltage fault. When the inverter bus voltage is lower than this value and it is running, it will output Err12 undervoltage fault. At the same time, the reset mode of the undervoltage fault can be selected through P9-17.

Function code	Name	Description (setting range)	Factory Default	Change
B2-06	Random PWM depth setting	0~6	0	☆

This function is only valid for VF. Random PWM can soften the monotonous harsh motor sound and reduce external electromagnetic interference. If the random PWM depth is different, the effect will not work, and 0 means invalid.

Function code	Name	Description (setting range)	Factory Default	Change
B2-07	0Hz operating mode selection	0~2	0	☆

0: no current output;

1: normal operation;

2: Output with stop DC braking current B1-16.

Function code	Name	Description (setting range)	Factory Default	Change
B2-08	Low frequency carrier limitation mode selection	0~1	0	☆

0: default limit mode;

1: The low frequency carrier frequency is not higher than  $\frac{1}{2}$  of the corresponding control mode; 2: Unlimited, all frequency bands have the same carrier frequency.

### Group B3: AIAO correction parameters

Function code	Name	Description (setting range)	Factory Default	Change
B3-00	AI1 shows voltage 1	-9.999V~10.000V	3.000V	☆
B3-01	AI1 measured voltage 1	-9.999V~10.000V	3.000V	☆
B3-02	AI1 shows voltage 2	-9.999V~10.000V	8.000V	☆
B3-03	AI1 measured voltage 2	-9.999V~10.000V	8.000V	☆
B3-04	AI2 shows voltage 1	-9.999V~10.000V	3.000V	☆
B3-05	AI2 measured voltage 1	-9.999V~10.000V	3.000V	☆
B3-06	AI2 shows voltage 2	-9.999V~10.000V	8.000V	☆
B3-07	AI2 measured voltage 2	-9.999V~10.000V	8.000V	☆

Function codes B3-00~B3-07 are used to correct the error between the actual input value of the AI analog quantity and the AI value displayed by the inverter, so as to eliminate the influence of the zero offset and linearity of the AI input port. This group of functional parameters has been calibrated before leaving the factory, and the user can calibrate it again according to the on-site usage, but the parameters will be restored together when restoring the factory defaults. Calibration is generally not required at the application site.

The measured voltage refers to the actual voltage measured by a multimeter and other measuring instruments, and the displayed voltage refers to the displayed voltage value sampled by the inverter. The displayed voltages of AI1 and AI2 correspond to function codes U1-19 and U1-20 respectively.

When calibrating, input two voltage values to each AI input port, and respectively input the value measured by the multimeter and the value read by the U0 group into the above function codes, then the inverter will automatically perform AI zero offset and calibration. Gain correction.

Function code	Name	Description (setting range)	Factory Default	Change
B3-12	AO1 target voltage 1	-9.999V~10.000V	3.000V	☆
B3-13	AO1 measured voltage 1	-9.999V~10.000V	3.000V	☆
B3-14	AO1 target voltage 2	-9.999V~10.000V	8.000V	☆
B3-15	AO1 measured voltage 2	-9.999V~10.000V	8.000V	☆
B3-16	AO2 target voltage 1	-9.999V~10.000V	3.000V	☆
B3-17	AO2 measured voltage 1	-9.999V~10.000V	3.000V	☆
B3-18	AO2 target voltage 2	-9.999V~10.000V	8.000V	☆
B3-19	AO2 measured voltage 2	-9.999V~10.000V	8.000V	☆

Function codes B3-12~B3-19 are used to correct the error between the actual output value of AO analog quantity and the theoretical output value. It has been calibrated at the factory, and generally does not need to be calibrated at the application site. When restoring the factory value, it will be restored to the factory calibration value.

The target voltage refers to the theoretical output voltage value of the inverter. U1-37 and U1-38 correspond to the target voltages of AO1 and AO2 respectively. The measured voltage refers to the actual output voltage value measured by instruments such as a multimeter.

During calibration, after inputting the target voltage and the measured voltage in the corresponding function code, the inverter will automatically correct the output value.

## Group B4: Master-slave control parameters

Master-slave control refers to the data exchange between two or more inverters through point-to-point communication, so as to achieve the effect of speed synchronization or current balance between multiple inverters, and is often used in multi-drive occasions. For example, sand excavators, coal mine belt conveyors, etc. Please correctly set the inverter communication group P8 group before use.

When using 485 communication for master-slave control, the inverter can no longer communicate normally with the host computer using 485 communication, otherwise the system will work abnormally. There are the following precautions when using master-slave control:

### Master and slave directions are determined

When master-slave control and speed synchronous control is required, make sure that the actual running directions of the master and slave motors are the same before running.

When the master and slave directions are inconsistent, the actual running direction of the motor can be changed by selecting P0-13 through the motor direction or changing the wiring sequence between the motor and the output terminal of the inverter.

### Master and slave control parameter setting

When multiple inverters are used to drive the same load, there are two control methods for the master and slave:

- 1) The master control mode P0-03 is set to vector, and the slave is vector and torque control. This method is used in most cases.
- 2) The master control mode P0-03 is set to VF, and the slave P0-03 is also set to VF. At this time, please set the appropriate sag rate P7-18, please refer to P7-18 for the setting method. Otherwise, the current between master and slave will be unbalanced;
- 3) When the mechanical transmission ratios of the master and slave are the same, the maximum frequency P0-14 of the master and slave inverters must be the same;
- 4) When the host B4-02=0, the acceleration and deceleration time of the slave should be set to 0; when the host B4-02=1, the acceleration and deceleration time of the slave should be consistent with the host;
- 5) There can only be one master in a system, but there can be multiple slaves. At the same time, according to the communication method used, KD600 only supports 485 communication.

Function code	Name	Description (setting range)	Factory Default	Change
B4-00	Master-slave control enable selection:	0~1	0	★

0: Disable;

1: Enable, after enabling master-slave control.

Function code	Name	Description (setting range)	Factory Default	Change
B4-01	Master-slave selection:	0~1	0	★

0: host;

1: Slave.

Function code	Name	Description (setting range)	Factory Default	Change
B4-07	Frequency deviation threshold	0.20%~10.00%	0.50%	☆
B4-08	Master-slave communication drop detection time	0.00s~10.0s	0.1s	☆

Set the master-slave communication interruption detection time, no detection when it is 0. Note: <1> Only the slave takes effect, <2> Only the master takes effect.

### Group B5: Brake function parameters

Function code	Name	Description (setting range)	Factory Default	Change
B5-00	Brake control enable selection:	0~1	0	★

The brake control process is shown in Figure 6-31 below:

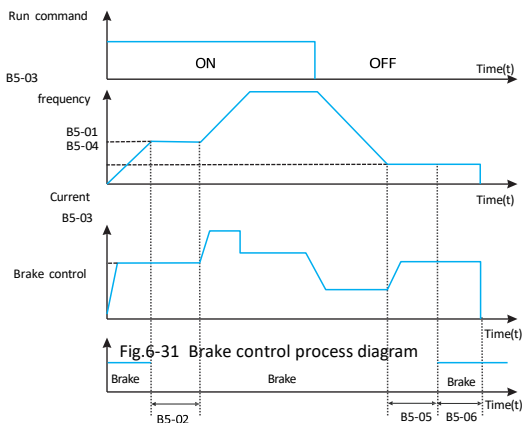

Fig.6-31 Brake control process diagram

**The braking process is as follows:**

- ➊ After the inverter receives the running command, it will accelerate to the brake frequency set by B5-01.
- ➋ When the frequency reaches the frequency set by B5-01, the brake release signal is output through the function of DO terminal No. 32 "brake control output" to control the brake release.
- ➌ Run at constant speed at the release frequency. During this period, the inverter output current does not exceed the current set by B5-03.
- ➍ When the running time of the inverter at the release frequency reaches the set value of B5-02, it starts to accelerate to run to the set frequency.
- ➎ After the inverter receives the stop command, it will decelerate to the brake frequency set by B5-04, and run at a constant speed at this frequency.
- ➏ After the running frequency reaches the set value of B5-04, after delaying the holding time of the brake frequency set by B5-05, the brake signal is output through the function of DO terminal No. 32 "brake control output" to control the brake.
- ➐ After the output brake signal time of the switch output "brake control" terminal reaches the set value of B5-06, the inverter blocks the output and enters the stop state.

Function code	Name	Description (setting range)	Factory Default	Change
B5-01	brake release frequency	0.00Hz~20.00Hz	2.50Hz	★

When the frequency reaches this set value, the switch output "brake control" terminal outputs the brake signal to control the release of the brake. This value can be set according to the rated slip frequency of the motor. In V/F control, it can be set slightly larger.

Function code	Name	Description (setting range)	Factory Default	Change
B5-02	Brake release frequency maintenance time	0.0s~20.0s	1.0s	★

After the switch output "brake control" terminal outputs the brake signal, the inverter will suspend acceleration within the set time. After the set time is reached, the acceleration operation starts again. Please set it reasonably according to the time required for the mechanical release of the brake.

Function code	Name	Description (setting range)	Factory Default	Change
B5-03	Current limit value during holding brake	50.0%~200.0%	120.0%	★

Before the inverter starts to accelerate from the brake release frequency, that is, before the brake mechanism is not completely released, the current is limited to this value.

Function code	Name	Description (setting range)	Factory Default	Change
B5-04	Brake pull-in frequency	0.00Hz~20.00Hz	1.50Hz	★

After the inverter receives the stop command, it will decelerate and run to the brake frequency set by B5-04, and run at a constant speed at this frequency, waiting for the output brake control signal.

Function code	Name	Description (setting range)	Factory Default	Change
B5-05	Brake pull-in delay time	0.0s~20.0s	0.0s	★

After the running frequency reaches the brake frequency, delay the brake waiting time set by B5-05. Then the switch output "brake control" terminal outputs the brake release signal to control the brake.

Function code	Name	Description (setting range)	Factory Default	Change
B5-06	Holding time of brake pull-in frequency	0.0s~20.0s	1.0s	★

After the switch output "brake control" terminal outputs the brake release signal, keep the time set by B5-06 to ensure that the brake mechanism is fully closed. Then the inverter blocks the output and enters the stop state.

## Group B6: Sleep wakeup function parameters

This group of parameters is mainly used to realize the sleep and wake-up functions in constant pressure water supply applications. Please pay attention to the following matters when using:

- ② select the mode B6-00 to control the sleep function according to the application requirements;
- ① the frequency source uses PID, the operation of PID in sleep state is affected by the function code PA-29. At this time, the operation when PID is stopped must be selected (PA-29=1);
- ③ Under normal circumstances, please set the wake-up frequency ((100.0%-B6-03 difference)\*P0-14 maximum output frequency) greater than the sleep frequency B6-01.

Function code	Name	Description (setting range)	Factory Default	Change
B6-00	Hibernate selection	0~3	0	☆

0: The sleep function is invalid

1: Digital input terminal DI controls sleep function

After the stator digital input DI terminal is defined as function No. 53, when DI is valid, it will go to sleep after delaying the time set in B6-02.

2: The sleep function is controlled by the PID setting value and feedback value. At this time, the frequency source P0-06 of the inverter must be PID, refer to Figure 5-28.

3: Control the sleep function according to the operating frequency

During the operation of the inverter, when the set frequency is less than or equal to the sleep frequency of B6-01, it will enter the sleep state, and vice versa.

If the set frequency of the inverter is greater than the wake-up frequency (B6-03 wake-up difference \* P0-14 maximum output frequency), it will enter the wake-up state.

Function code	Name	Description (setting range)	Factory Default	Change
B6-01	Sleep frequency	0.00Hz~P0-14	0.00Hz	☆

<1> When B6-00=1, this function is invalid;

When the sleep function is effective and the running frequency is lower than this value, after the sleep delay time B6-02, the inverter starts to sleep (stop).

See illustration: A = PID output; B = PID feedback value.

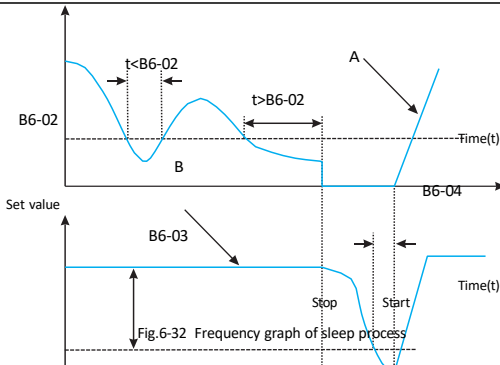

Fig.6-32 Frequency graph of sleep process

Function code	Name	Description (setting range)	Factory Default	Change
B6-02	Sleep delay	0.0s~3600.0s	20.0s	☆

Set the sleep delay time. Refer to Figure 6-32 for its function.

Function code	Name	Description (setting range)	Factory Default	Change
B6-03	Wake-up difference	0.0%~100.0%	10.0%	☆

When B6-00=2, this parameter takes the maximum pressure as the reference object, that is, the maximum pressure is 100%;

When B6-00=3, this parameter takes the maximum frequency P0-14 as the reference object, that is, the maximum frequency is 100%;

When the wake-up difference between the given value and the feedback value exceeds the value defined by this parameter, the PID regulator restarts after the wake-up delay B6-04. PA-04=0 positive effect, wake-up value = set value - wake-up difference; PA-04=1 reverse effect, wake-up value = set value + wake-up difference.

See illustration:

- C = wake-up value, when parameter PA-04=1.
- D = wake-up value, when parameter PA-04=0.

## Chapter 6 Description of Function Codes

- E = The feedback value is greater than the wake-up value, and the duration exceeds parameter B6-04 (wake-up delay), and the PID function restarts.
- F = The feedback value is less than the wake-up value, and the duration exceeds parameter B6-04 (wake-up delay), and the PID function restarts.

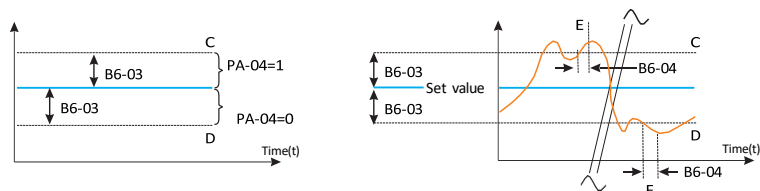

Figure 6-33. Wake up diagram

Function code	Name	Description (setting range)	Factory Default	Change
B6-04	Wake up delay	0.0s~3600.0s	0.5s	☆

Set the wake-up delay time, refer to Figure 6-33 for the function.

Function code	Name	Description (setting range)	Factory Default	Change
B6-05	Sleep delay frequency output selection	0~1	0	☆

0: PID automatic adjustment; 1: Sleep frequency B6-01.

## Group U0: Fault logging parameters

The inverter provides 3 groups of fault record parameters, all of which are read-only parameters, which are convenient for users to view and troubleshoot inverter fault-related information. For details, please refer to Appendix B Function Code Parameter Table or Chapter VII

<<Fault Diagnosis Level Countermeasures>>.

## Group U1: Application Monitoring Parameters

The U1 parameter group is used to monitor the relevant variable information when the inverter is running. The customer can view it through the panel to facilitate on-site debugging, or read the parameter group value through communication for monitoring by the host computer. The communication address is 0x71xx.

Among them, U1-00~U1-31 are the running and stop monitoring parameters defined in P7-29 and P7-30.

Function code	Name	Smallest unit	Change
U1-00	Operating frequency (Hz)	0.01Hz	●
U1-01	Set frequency (Hz)	0.01Hz	●
U1-02	Bus voltage (V)	0.1V	●
U1-03	Output voltage (V)	1V	●
U1-04	Output current (A)	0.1A	●
U1-05	Output power (Kw)	0.1kW	●
U1-06	DI input status, hexadecimal number	1	●

Displays the current DI terminal input status value. After conversion into binary data, each bit corresponds to a DI input signal, 1 indicates that the input is a high-level signal, and 0 indicates that the input is a low-level signal. The corresponding relationship between each bit and the input terminal is as follows:

Bit0	Bit1	Bit2	Bit3	Bit4	Bit5	Bit6	Bit7
DI1	DI2	DI3	DI4	DI5	reserve	reserve	reserve
Bit8	Bit9	Bit10	Bit11	Bit12	Bit13	Bit14	Bit15
reserve	reserve	reserve	reserve	reserve	reserve	reserve	reserve

## Chapter 6 Description of Function Codes

Function code	Name	Smallest unit	Change
U1-07	DO output status, hexadecimal number	1	●

Displays the current DO terminal output status value. After conversion into binary data, each bit corresponds to a DO signal, 1 means the output is high, and 0 means the output is low. The corresponding relationship between each bit and the output terminal is as follows:

Bit0	Bit1	Bit2	Bit3	Bit4	Bit5	Bit6	Bit7
RELAY 1	RELAY 2	Y1	reserve	reserve	reserve	reserve	reserve
Bit8	Bit9	Bit10	Bit11	Bit12	Bit13	Bit14	Bit15
reserve	reserve	reserve	reserve	reserve	reserve	reserve	reserve

Function code	Name	Smallest unit	Change
U1-08	Voltage after AI1 correction	0.01V	●
U1-09	Voltage after AI2 correction	0.01V	●
U1-10	PID set value, PID set value (percentage)*PA-05	1	●
U1-11	PID feedback, PID feedback value (percentage)*PA-05	1	●
U1-12	Count value	1	●
U1-13	Length value	1	●
U1-14	Motor speed	rpm	●
U1-15	PLC stage, the current segment during multi-speed operation	1	●
U1-16	PULSE pulse input frequency	0.01kHz	●
U1-17	Feedback speed, the actual operating frequency of the motor	0.1Hz	●
U1-18	P7-38 Remaining time of timing time	0.1Min	●
U1-19	AI1 voltage before correction	0.001V	●
U1-20	Voltage before AI2 correction	0.001V	●
U1-21	DI5 high-speed pulse sampling line speed, refer to P7-71 for use	1m/min	●
U1-22	Load speed display (set load speed when stopped), refer to P7-31 for use	customize	●

Function code	Name	Smallest unit	Change
U1-23	The power-on time	1Min	●
U1-24	This running time	0.1Min	●
U1-25	PULSE pulse input frequency, different from U1-16 only in unit	1Hz	●
U1-26	Communication setting frequency value	0.01%	●
U1-27	Main frequency display	0.01Hz	●
U1-28	Auxiliary frequency display	0.01Hz	●
U1-29	Target torque, take the motor rated torque as 100%	0.1%	●
U1-30	Output torque, take the motor rated torque as 100%	0.1%	●
U1-31	Output torque, with the rated current of the inverter as 100%	0.1%	●
U1-32	Torque upper limit, the rated current of the inverter is 100%	0.1%	●
U1-33	VF separation target voltage	1V	●
U1-34	VF split output voltage	1V	●
U1-35	Reserve	—	●
U1-36	Motor serial number currently in use	1	●
U1-37	AO1 target voltage	0.01V	●
U1-38	AO2 target voltage	0.01V	●
U1-39	0~3	1	●
U1-40	Inverter current fault	1	●
U1-41	Agent time remaining	1h	●
U1-42	AC incoming line current	0.1A	●
U1-43	PLC current phase remaining time	0.1	●
U1-47	Cumulative running time 1 (cumulative running time = U1-47 + U1-48)	1h	●
U1-48	Cumulative running time 2 (cumulative running time = U1-47 + U1-48)	1min	●
U1-50	Motor temperature	1°C	●

**Note:**

Cumulative running time = Cumulative running time 1 + Cumulative running time 2 = U1-47 + U1-48.





# Chapter 7

## **Synchronous Motor Open Loop Vector (SVC) Commissioning Instructions**

---

7.1 Set the synchronization type, control method and motor parameters.....	244
7.2 Parameter identification.....	244
7.3 No-load test run.....	244
7.4 Quick start test run.....	244
7.5 Load and run.....	245

## 7.1 Set the synchronization type, control method and motor parameters

- 1 The motor type is set to synchronous motor and the control mode is SVC, P0-03=11.

### Note:

The ten digit of P0-03 is the motor type selection, and the one digit is the control mode; Tens place: 1: synchronous motor, 0: asynchronous motor; Ones place: 1: SVC, 2: VF, 3: Closed loop vector (reserved)

- 2 P4-01~P4-06 according to the actual motor parameters.

## 7.2 Parameter identification

- 1 Connect the motor, if there is a load, set P4-00 to 1; if it is an empty shaft, set P4-00 to 2, the digital tube will display TUNE, in order to ensure the control effect, the motor is best to be no-load and set P4-00 is 2.
- 2 Press the RUN key to perform parameter identification, and wait for TUNE to disappear, then the parameter identification ends.
- 3 The identification process lasts for about 1 minute, and you can press the STOP button in the middle to exit. During this period, current will be sent, run the motor at the set acceleration and deceleration time to 60% of the rated frequency of the motor to observe whether the motor runs smoothly, if not, press STOP to exit, reach 60% of the rated frequency of the motor, and decelerate to stop after a period of time.
- 4 After parameter identification, check whether the parameters of P4-17~ P4-20 are normal.

## 7.3 No-load test run

- 1 Set the speed to a smaller range, such as P0-11= 20Hz.
- 2 Press the run key to check whether the motor can accelerate to the set frequency and whether the motor current is small. If the motor can accelerate to the set frequency and the motor current is small, the inverter is basically normal. Set the frequency to the rated frequency of the motor and check whether the motor can accelerate to the set frequency.

#### **7.4 Quick start test run, set it when quick start and stop are required, otherwise skip this step**

Reduce the motor acceleration time (for example, set it to 1 second), change the speed loop and current loop PI parameter settings, and press the run key to check whether the motor can quickly accelerate to the set frequency.

#### **7.5 Load and run**

After the above 5 steps, you can run the motor with load and use the inverter normally.

**Note:**

Loading or changing the moment of inertia of the system, if the system response cannot achieve the expected effect, it is necessary to adjust the two parameters P3-04 and P3-06 appropriately. If you replace it with another motor, you generally need to set the rated frequency and rated current of the motor, and then perform parameter identification.





# Chapter 8

## **EMC (Electromagnetic Compatibility)**

---

8.1 Definition.....	248
8.2 Introduction to EMC Standards.....	248
8.3 EMC Guidance.....	248

### 8.1 Definition

Electromagnetic compatibility refers to the ability of electrical equipment to operate in an electromagnetic interference environment without interfering with the electromagnetic environment and to stably achieve its functions.

### 8.2 Introduction to EMC Standards

According to the requirements of the national standard GB/T12668.3, the inverter needs to meet the requirements of electromagnetic interference and anti-electromagnetic interference.

Our existing products implement the latest international standard: IEC/EN61800-3:2004 (Adjustable speed electrical power drive systems part 3: EMC requirements and specific test methods), which is equivalent to the national standard GB/T12668.3.

IEC/EN61800-3 mainly inspects the inverter from two aspects: electromagnetic interference and anti-electromagnetic interference. Electromagnetic interference mainly tests the radiated interference, conducted interference and harmonic interference of the inverter (for domestic inverters, there are requirements). The anti-electromagnetic interference mainly affects the conducted immunity, radiation immunity, surge immunity, rapid mutation pulse group immunity, ESD immunity and low frequency end immunity of the power supply of the inverter (specific test items are: 1. Input voltage sag, interruption and change immunity test; 2. Commutation notch immunity test; 3. Harmonic input immunity test; 4. Input frequency change test; 5. Input voltage unbalance test; 6. Input voltage fluctuation test) to test. Tested in accordance with the strict requirements of IEC/EN61800-3 above, our products are installed and used in accordance with the instructions shown in 8.3, and will have good electromagnetic compatibility in general industrial environments.

### 8.3 EMC Guidance

#### 8.3.1 Influence of harmonics:

High-order harmonics of the power supply will damage the inverter. Therefore, in some places where the quality of the power grid is relatively poor, it is recommended to install an AC input reactor.

### 8.3.2 Electromagnetic Interference and Installation Precautions

There are two kinds of electromagnetic interference, one is the interference of the electromagnetic noise in the surrounding environment to the inverter, and the other is the interference generated by the inverter to the surrounding equipment.

#### Installation Precautions:

- ❶ The grounding wire of the inverter and other electrical products should be well grounded;
- ❷ power input and output lines of the inverter and the weak current signal lines (such as control lines) should not be arranged in parallel as far as possible, and should be arranged vertically if possible;
- ❸ It is recommended to use shielded cables for the output power lines of the inverter, or use steel pipes to shield the power lines, and the shielding layer should be grounded reliably. For the leads of the disturbed equipment, it is recommended to use twisted-pair shielded control lines, and the shielding layer should be reliably grounded;
- ❹ the motor cable whose length exceeds 100m, it is required to install an output filter or reactor.

### 8.3.3 How to deal with the interference caused by peripheral electromagnetic equipment to the inverter

Generally, the reason for the electromagnetic influence on the inverter is that a large number of relays, contactors or electromagnetic brakes are installed near the inverter. When the inverter is disturbed and malfunctions due to this, it is recommended to take the following solutions:

- ❶ Install a surge suppressor on the device that generates interference;
- ❷ a filter on the input end of the inverter, refer to 8.3.6 for details;
- ❸ Use shielded cables for the lead wires of the control signal line and the line of the inverter and ground the shielding layer reliably.

### 8.3.4 How to deal with the interference caused by the frequency converter to the peripheral equipment

- 1** The noise in this part is divided into two types: one is the radiated interference of the inverter, and the other is the conducted interference of the inverter. These two kinds of interference make the surrounding electrical equipment subject to electromagnetic or electrostatic induction. This in turn causes the device to malfunction. For several different interference situations, refer to the following solutions:
- 2** When receivers and sensors used for measurement generally have weak signals. If they are close to the inverter or in the same control cabinet, they are prone to interference and malfunction. It is recommended to use the following solutions: try to keep away from interference sources; do not arrange signal lines and power lines in parallel, especially do not bundle them in parallel; use shielded lines for signal lines and power lines, and the grounding is good; add a ferrite magnetic ring to the output side of the inverter (select the suppression frequency at 30~1000MHz range), and winding 2~3 turns in the same direction, for bad conditions, you can choose to install an EMC output filter;
- 3** When the interfered equipment and the inverter use the same power it will cause conduction interference. If the above methods cannot eliminate the interference, an EMC filter should be installed between the inverter and the power supply (refer to 7.3.6 for details). type operation);
- 4** peripheral equipment is grounded separately, which can eliminate the interference caused by the leakage current of the ground wire of the inverter when the ground is shared.

### 8.3.5 Leakage Current and Handling

There are two forms of leakage current when using the inverter: one is the leakage current to the ground; the other is the leakage current between lines.

#### Factors affecting ground leakage current and solutions:

- 1** There is a distributed capacitance between the wire and the ground. The larger the distributed capacitance, the larger the leakage current; effectively reduce the distance between the inverter and the motor to reduce the distributed capacitance. The greater the carrier frequency, the greater the leakage current. The carrier frequency can be lowered to reduce leakage current.

However, reducing the carrier frequency will increase the motor noise. Please note that adding a reactor is also an effective way to solve the leakage current.

② and solutions that cause leakage current between lines:

There is distributed capacitance between the output wiring of the inverter. If the current passing through the wiring contains high-order harmonics, it may cause resonance and cause leakage current. At this time, using a thermal relay may cause it to malfunction.

The solution is to reduce the carrier frequency or install an output reactor. When using the inverter, it is recommended not to install a thermal relay between the inverter and the motor, and use the electronic overcurrent protection function of the inverter.

### 8.3.6 Precautions for installing EMC input filter on power input

When installing an EMCS input filter at the power input end, pay attention to the following:

- ① When using the filter, please use it strictly according to the rated value; if the filter is a Class I electrical appliance, the ground of the metal casing of the filter should be in good contact with the metal ground of the installation cabinet in a large area, and good electrical continuity is required, otherwise there will be electric shock. Dangerous and seriously affect the EMC effect;
- ② In the EMC test, it is found that the filter ground must be connected to the same common ground as the PE terminal of the inverter, otherwise the EMC effect will be seriously affected;
- ③ Install the filter as close to the power input end of the inverter as possible;
- ④ EMC input filter cannot be used at the output end of the inverter for filtering.





# Chapter 9

## Troubleshooting and Countermeasures

---

9.1	Fault alarm and countermeasures.....	254
9.2	Common faults and their solutions.....	259
9.3	Common faults of synchronous motors and their solutions. ....	261

## 9.1 Fault alarm and countermeasures

If a fault occurs during the system operation, the inverter will immediately protect the motor to stop the output, and the corresponding inverter fault relay contact will act. The inverter panel displays the fault code. The fault type and common solution corresponding to the fault code are shown in the following table. The list in the table is for reference only, please do not repair or modify it without authorization. If the fault cannot be eliminated, please seek technical support from our company or the product agent.

Table 9-1 Fault alarm and countermeasures

Fault name	Panel display	Troubleshooting	Troubleshooting Countermeasures
Inverter module protection	Err01	<ul style="list-style-type: none"> <li>◆ Check if the motor connection terminals U, V and W are short-circuited between phases or to ground</li> <li>◆ Check if the module overheated?</li> <li>◆ Check if the internal wiring of the inverter is loose</li> <li>◆ Check if the main control board, driver board or module is normal</li> </ul>	<ul style="list-style-type: none"> <li>◆ Check contact short circuit</li> <li>◆ Check if the fans and air ducts are normal?</li> <li>◆ Connect all loose wires</li> <li>◆ Seek technical support</li> </ul>
Overcurrent during acceleration	Err04	<ul style="list-style-type: none"> <li>◆ Check if there is grounding or short circuit in the output circuit of the inverter</li> <li>◆ Check if motor parameters are incorrect</li> <li>◆ Check if acceleration time is too short</li> <li>◆ Check if torque boost or inappropriate curve</li> <li>◆ Check if input voltage is low</li> <li>◆ Check if the rotating motor</li> <li>◆ Check if load during acceleration</li> <li>◆ Check if motor selection is too small</li> </ul>	<ul style="list-style-type: none"> <li>◆ Eliminate peripheral faults</li> <li>◆ Check parameters and parameter identification</li> <li>◆ Check if the acceleration time</li> <li>◆ Check if the V/F boost torque or curve</li> <li>◆ Check if the voltage to the normal range</li> <li>◆ Check if the speed tracking start or wait for the motor to stop before starting</li> <li>◆ Cancel sudden load</li> <li>◆ Check if inverters with larger power levels</li> </ul>

Fault name	Panel display	Troubleshooting	Troubleshooting Countermeasures
Overcurrent during deceleration	Err05	<ul style="list-style-type: none"> <li>◆ <del>is</del> grounding or short circuit in the output circuit of the inverter</li> <li>◆ <del>motor</del> parameters are incorrect</li> <li>◆ <del>de</del>celeration time is too short</li> <li>◆ <del>input</del> voltage is low</li> <li>◆ <del>Set</del> sudden load during deceleration</li> <li>◆ <del>braking</del> unit and braking resistor</li> <li>◆ <del>magnetic</del> flux braking gain is too large</li> </ul>	<ul style="list-style-type: none"> <li>◆ Eliminate peripheral faults</li> <li>◆ <del>motor</del> parameter identification</li> <li>◆ <del>the</del> deceleration time</li> <li>◆ <del>the</del> voltage to the normal range</li> <li>◆ <del>Cancel</del> sudden load</li> <li>◆ <del>braking</del> unit and resistance</li> <li>◆ <del>Reduce</del> the magnetic flux braking gain</li> </ul>
Overcurrent in constant speed operation	Err06	<ul style="list-style-type: none"> <li>◆ <del>is</del> grounding or short circuit in the output circuit of the inverter</li> <li>◆ <del>motor</del> parameters are incorrect</li> <li>◆ <del>input</del> voltage is low</li> <li>◆ <del>Where</del> a sudden load during operation?</li> <li>◆ <del>Inverter</del> selection is too small</li> </ul>	<ul style="list-style-type: none"> <li>◆ Eliminate peripheral faults</li> <li>◆ <del>parameters</del> and parameter identification</li> <li>◆ <del>the</del> voltage to the normal range</li> <li>◆ <del>Cancel</del> sudden load</li> <li>◆ <del>Set</del> the inverter with a larger power level</li> </ul>
Overvoltage during acceleration	Err08	<ul style="list-style-type: none"> <li>◆ <del>input</del> voltage is too high</li> <li>◆ <del>is</del> an external force driving the motor to run during the acceleration process</li> <li>◆ <del>acceleration</del> time is too short</li> <li>◆ <del>braking</del> unit and braking resistor</li> <li>◆ <del>motor</del> parameters are incorrect</li> </ul>	<ul style="list-style-type: none"> <li>◆ <del>the</del> voltage to the normal range</li> <li>◆ <del>external</del> power or install braking resistor</li> <li>◆ <del>the</del> acceleration time</li> <li>◆ <del>braking</del> unit and resistor</li> <li>◆ <del>Check</del> parameters and parameter identification</li> </ul>
Overvoltage during deceleration	Err09	<ul style="list-style-type: none"> <li>◆ <del>input</del> voltage is too high</li> <li>◆ <del>is</del> an external force driving the motor to run during the deceleration process</li> <li>◆ <del>de</del>celeration time is too short</li> <li>◆ <del>braking</del> unit and braking resistor</li> </ul>	<ul style="list-style-type: none"> <li>◆ <del>the</del> voltage to the normal range</li> <li>◆ <del>external</del> power or install braking resistor</li> <li>◆ <del>the</del> deceleration time</li> <li>◆ <del>Install</del> braking unit and resistor</li> </ul>

Fault name	Panel display	Troubleshooting	Troubleshooting Countermeasures
Overvoltage during constant speed operation	Err10	<ul style="list-style-type: none"> <li>◆ Input voltage is too high</li> <li>◆ Is an external force driving the motor to run during the acceleration process</li> </ul>	<ul style="list-style-type: none"> <li>◆ Reduce the voltage to the normal range</li> <li>◆ External power or install braking resistor</li> </ul>
Undervoltage fault	Err12	<ul style="list-style-type: none"> <li>◆ Instantaneous power failure</li> <li>◆ Input voltage of the inverter is not within the range required by the specification</li> <li>◆ Bus voltage is abnormal</li> <li>◆ Rectifier bridge and buffer resistance are abnormal</li> <li>◆ Abnormal drive board</li> <li>◆ Control panel is abnormal</li> </ul>	<ul style="list-style-type: none"> <li>◆ Reset fault</li> <li>◆ Reduce the voltage to the normal range</li> <li>◆ Seek technical support</li> </ul>
Drive overload fault	Err13	<ul style="list-style-type: none"> <li>◆ The load is too large or the motor is blocked</li> <li>◆ Inverter selection is too small</li> </ul>	<ul style="list-style-type: none"> <li>◆ Reduce the load and check the motor and mechanical conditions</li> <li>◆ Replace the inverter with a larger power level</li> </ul>
Motor overload fault	Err14	<ul style="list-style-type: none"> <li>◆ The setting of motor protection parameter P9-01 is appropriate</li> <li>◆ The load is too large or the motor is blocked</li> <li>◆ Inverter selection is too small</li> </ul>	<ul style="list-style-type: none"> <li>◆ Do not set this parameter</li> <li>◆ Reduce the load and check the motor and mechanical condition</li> <li>◆ Replace the inverter with a larger power level</li> </ul>
drive overheating	Err15	<ul style="list-style-type: none"> <li>◆ Ambient temperature is too high</li> <li>◆ Air duct is blocked</li> <li>◆ Fan is damaged</li> <li>◆ Inverter module thermistor is damaged</li> <li>◆ Inverter module is damaged</li> </ul>	<ul style="list-style-type: none"> <li>◆ Reduce the ambient temperature</li> <li>◆ Clean the air duct</li> <li>◆ Replace the fan</li> <li>◆ Replace the thermistor</li> <li>◆ Replace the inverter module</li> </ul>

Fault name	Panel display	Troubleshooting	Troubleshooting Countermeasures
Current detection failure	Err17	<ul style="list-style-type: none"> <li>◆ Check the internal wiring of the inverter is loose</li> <li>◆ Check the current detection device normal?</li> <li>◆ Check the main control board or driver board is normal</li> </ul>	<ul style="list-style-type: none"> <li>◆ Check the wiring</li> <li>◆ Ask technical support</li> </ul>
Short to ground fault	Err20	<ul style="list-style-type: none"> <li>◆ Check for short circuit to ground</li> </ul>	<ul style="list-style-type: none"> <li>◆ Replace the cable or motor</li> </ul>
Input phase loss fault	Err23	<ul style="list-style-type: none"> <li>◆ Three-phase input power supply is abnormal</li> <li>◆ Driver board is abnormal</li> <li>◆ Lightning protection board is abnormal</li> <li>◆ Main control board is abnormal</li> </ul>	<ul style="list-style-type: none"> <li>◆ Find and eliminate problems in peripheral circuits</li> <li>◆ Ask technical support</li> </ul>
Output phase loss fault	Err24	<ul style="list-style-type: none"> <li>◆ Lead wire from the inverter to the motor is abnormal</li> <li>◆ Three-phase output of the inverter is unbalanced when the motor is running</li> <li>◆ Driver board is abnormal</li> <li>◆ Module exception</li> </ul>	<ul style="list-style-type: none"> <li>◆ Find peripheral faults</li> <li>◆ Check whether the three-phase windings of the motor are normal and troubleshoot</li> <li>◆ Ask technical support</li> </ul>
read and write failure	Err25	<ul style="list-style-type: none"> <li>◆ EEPROM chip damaged</li> </ul>	<ul style="list-style-type: none"> <li>◆ Replace the main control board</li> </ul>
Parameter	Err27	<ul style="list-style-type: none"> <li>◆ Is the host computer working?</li> <li>◆ Is the communication connection normal?</li> <li>◆ Check the communication parameter P8 group is correct</li> </ul>	<ul style="list-style-type: none"> <li>◆ Check the wiring of the host computer, etc.</li> <li>◆ Check the communication wiring</li> <li>◆ Check the parameters of P8 group</li> </ul>
Parameter	Err28	<ul style="list-style-type: none"> <li>◆ Is external normally open or normally closed fault signal through multi-function DI terminal</li> </ul>	<ul style="list-style-type: none"> <li>◆ Fault reset</li> </ul>
Excessive speed deviation	Err29	<ul style="list-style-type: none"> <li>◆ Load is too heavy and the set acceleration time is too short</li> <li>◆ Setting of fault detection parameters P9-31 and P9-32 is unreasonable</li> </ul>	<ul style="list-style-type: none"> <li>◆ Check the set acceleration and deceleration time</li> <li>◆ P9-31 and P9-32</li> </ul>

## Chapter 9 Troubleshooting and Countermeasures

Fault name	Panel display	Troubleshooting	Troubleshooting Countermeasures
User-defined fault 1	Err30	<ul style="list-style-type: none"> <li>Defined fault 1 signal input through multi-function terminal DI</li> </ul>	<ul style="list-style-type: none"> <li>Reset</li> </ul>
User-defined fault 2	Err31	<ul style="list-style-type: none"> <li>Defined fault 2 signal input through multi-function terminal DI</li> </ul>	<ul style="list-style-type: none"> <li>Reset</li> </ul>
PID feedback lost at runtime	Err32	<ul style="list-style-type: none"> <li>Feedback value is less than the set value of PA-13</li> </ul>	<ul style="list-style-type: none"> <li>Check the feedback signal or reset the PA-13</li> </ul>
Fast current limiting	Err33	<ul style="list-style-type: none"> <li>Load is too large or the stall occurs</li> <li>Set acceleration time is too short</li> </ul>	<ul style="list-style-type: none"> <li>Check the load or replace the inverter with a higher power</li> <li>Extend the acceleration time</li> </ul>
load drop failure	Err34	<ul style="list-style-type: none"> <li>The load drop detection condition is reached, please refer to P9-28-P9-30 for specific use.</li> </ul>	<ul style="list-style-type: none"> <li>Check or reset detection conditions</li> </ul>
input power failure	Err35	<ul style="list-style-type: none"> <li>Input voltage is not within the specified range</li> <li>On and off too frequently</li> </ul>	<ul style="list-style-type: none"> <li>Adjust the input voltage</li> <li>Extend the power cycle</li> </ul>
parameter storage exception	Err37	<ul style="list-style-type: none"> <li>Main communication between DSP and EEPROM chip</li> </ul>	<ul style="list-style-type: none"> <li>Check the main control board</li> <li>Contact manufacturer service</li> </ul>
The running time has arrived	Err39	<ul style="list-style-type: none"> <li>Current running time of the inverter &gt; the set value of P7-38</li> </ul>	<ul style="list-style-type: none"> <li>Reset</li> </ul>
Accumulated running time reached	Err40	<ul style="list-style-type: none"> <li>Accumulated running time reaches the set value P7-20</li> </ul>	<ul style="list-style-type: none"> <li>Use parameter initialization function 2 to clear the recording time or reset the accumulated running time</li> </ul>
Switching motors during operation	Err42	<ul style="list-style-type: none"> <li>Switch the motor through the terminals during operation</li> </ul>	<ul style="list-style-type: none"> <li>Do not switch after shutdown</li> </ul>

Fault name	Panel display	Troubleshooting	Troubleshooting Countermeasures
Master-slave control communication dropped	Err46	<ul style="list-style-type: none"> <li>▶ master is not set but the slave is set</li> <li>▶ communication line is abnormal or the communication parameters are incorrect</li> </ul>	<ul style="list-style-type: none"> <li>◀ the host and reset the fault</li> <li>◀ the communication line and communication parameter P8 group</li> </ul>

## 9.2 Common faults and their solutions

The following fault conditions may be encountered during the use of the inverter, please refer to the following methods for simple fault analysis.

Table 9-2 Common faults and their solutions

Serial number	Fault phenomenon	Possible reason	Solution
1	No display when power on	<ul style="list-style-type: none"> <li>▶ grid voltage is not available or too low</li> <li>▶ switching power supply on the drive board of the inverter is faulty</li> <li>▶ rectifier bridge is damaged</li> <li>▶ buffer resistance of the inverter is damaged</li> <li>▶ panel and keyboard failure</li> <li>▶ connection between the control board, the driver board and the keyboard is broken</li> </ul>	<ul style="list-style-type: none"> <li>◀ the input power</li> <li>◀ the bus voltage</li> <li>▶ plug the keyboard and the 30-pin cable</li> <li>▶ manufacturer service</li> </ul>
2	Display "Err20" alarm when power on	<ul style="list-style-type: none"> <li>▶ motor or output line is short-circuited to ground</li> <li>▶ inverter is damaged</li> </ul>	<ul style="list-style-type: none"> <li>▶ shaker to measure the insulation of the motor and output line</li> <li>▶ manufacturer service</li> </ul>

Serial number	Fault phenomenon	Possible reason	Solution
3	Err15 (module overheating) fault is reported frequently	<ul style="list-style-type: none"> <li>◆ Carrier frequency setting is too high</li> <li>◆ Fan is damaged or the air duct is blocked</li> <li>◆ Internal components of the inverter are damaged (thermocouple or other)</li> </ul>	<ul style="list-style-type: none"> <li>◆ Reduce the carrier frequency (P0-26)</li> <li>◆ Clean the fan and clean the air duct</li> <li>◆ Ask manufacturer service</li> </ul>
4	The motor does not rotate after the inverter is running	<ul style="list-style-type: none"> <li>◆ Motor and motor wire</li> <li>◆ Incorrect setting of inverter parameters (motor parameters)</li> <li>◆ Connection between the drive board and the control board</li> <li>◆ Drive board failure</li> </ul>	<ul style="list-style-type: none"> <li>◆ Reconfirm the connection between the inverter and the motor</li> <li>◆ Clean the motor or clear the mechanical fault</li> <li>◆ Check and reset the motor parameters</li> </ul>
5	DI terminal failure	<ul style="list-style-type: none"> <li>◆ Parameter setting error</li> <li>◆ External signal error</li> <li>◆ Position of the DI DIP switch is wrong</li> <li>◆ Control board failure</li> </ul>	<ul style="list-style-type: none"> <li>◆ Check and reset the relevant parameters of the P5 group</li> <li>◆ Reconfirm the external signal line</li> <li>◆ Confirm whether the position of the DI DIP switch is consistent with the wiring method</li> <li>◆ Ask manufacturer service</li> </ul>
6	The inverter frequently reports overcurrent and overvoltage faults	<ul style="list-style-type: none"> <li>◆ Motor parameters are set incorrectly</li> <li>◆ Inappropriate acceleration and deceleration time</li> <li>◆ Load fluctuation</li> </ul>	<ul style="list-style-type: none"> <li>◆ Check the motor parameters or perform motor tuning</li> <li>◆ Set the appropriate acceleration and deceleration time</li> <li>◆ Ask manufacturer service</li> </ul>

### 9.3 Common faults of synchronous motors and their solutions

#### 9.3.1 Motor starts with heavy load

If the motor does not start normally with load, you can try the following operations:

**1** Increase the upper limit of torque current (P3-21)

When the load is greater than the torque output of the inverter, the inverter will be in a locked-rotor state, and P3-21 can be appropriately increased at this time.

**2** the speed PI adjustment parameter, modify the resistance value  $\sigma$  static identification to correct the motor resistance.

The motor resistance parameter (P4-17) will significantly affect the load carrying capacity of the motor at low speed. When the resistance parameter (P4-17) exceeds the actual resistance value by too much (for example, 200% of the actual resistance value), it may cause the motor to reverse at low speed at the upper torque limit current. When the resistance parameter (P4-17) is too much lower than the actual resistance value (for example, 50% of the actual resistance value), it may cause the motor to run in a step-by-step manner, or rotate for a period of time and stop for a period of time. Increasing the speed P value P3-04 at low speed and reducing the speed loop integral time P3-05 may improve the problem caused by too small resistance parameters.

#### 9.3.2 Adjust the speed loop PI parameters (under normal circumstances do not need to adjust)

**1** In general, if the proportional coefficient of speed PI adjustment is too large, it will cause high-frequency vibration of the speed, and the mechanical vibration or electromagnetic noise will increase significantly; if the proportional coefficient is too small and the integration time is too small or the load inertia is too large, it will cause low-frequency vibration of the speed and overshoot of the speed. Obviously, if there is no discharge measures, there may be overvoltage.

**2** You need to adjust the speed PI parameter, first increase the integral time, increase the ratio if the speed does not oscillate, and then decrease the integral time if the effect is not satisfactory. Generally, the larger the inertia of the system, the smaller the integral time and the larger the proportional coefficient. If the speed filter coefficient is increased, the integral time should be increased, and the proportion can be increased appropriately.

### Note:

The inertia of the drive system is equal to the motor inertia plus the load inertia. The inertia of the motor is proportional to the mass of the motor and the square of the diameter of the motor; the inertia of the transmission load is proportional to the mass of the load and the square of the diameter of the transmission wheel; if there is a deceleration or speed-up device, the inertia is proportional to the speed-up ratio and inversely proportional to the deceleration ratio.

For loads with large inertia, if fast speed response is required, the integration time needs to be reduced, but it is easy to cause speed overshoot, resulting in overvoltage of the inverter, and a discharge device is required to discharge. If there is no discharge device, the integration time can be increased.

### 9.3.3 Adjust the PI parameters of the current loop (under normal circumstances, do not need to adjust)

Under normal circumstances, increasing the proportional coefficient and the integral coefficient will speed up the current response speed, but if too large, it will cause speed shock (specifically, the motor does not rotate, or rotates in random directions, and emits high-frequency electromagnetic noise at the same time). If you need to adjust it, first Adjust the proportional coefficient, and adjust the integral coefficient if the effect is not satisfactory. The PI parameters of the current loop are related to the motor stator resistance, inductance, carrier frequency of the system, and current sampling filter time. When the carrier frequency of the system remains unchanged, the proportional coefficient is proportional to the inductance, and the integral coefficient is proportional to the resistance. Therefore, by identifying The output parameter can roughly determine the adjustment direction of this parameter.



# Chapter 10

---

## Appendix

Appendix A: Modbus communication protocol. ....	266
Appendix B: Introduction to Expansion Card. ....	276
Appendix C: Expansion Card Details. ....	298

## Appendix A: Modbus communication protocol

KD600 series inverter provides RS232/RS485 communication interface and supports Modbus communication protocol. Users can realize centralized control through computer or PLC, set inverter running commands, modify or read function code parameters, and read inverter working status and fault information through this communication protocol.

### 1. Agreement

The serial communication protocol defines the content and format of information transmitted in serial communication. It includes: host polling (or broadcast) format; host encoding method, including: function code required for action, transmission data and error checking, etc. The response of the slave also adopts the same structure, including: action confirmation, return data and error checking, etc. If the slave has an error in receiving the information, or cannot complete the action required by the master, it will organize a fault message as a response and feed it back to the master.

### 2. Application method

The inverter is connected to the "single master and multiple slave" PC/PLC control network with RS232/RS485 bus.

### 3. Bus structure

#### ( 1 ) The interface way RS232/RS485 hardware interface ( 2 )

##### Transfer method

Asynchronous serial, half-duplex transmission mode. At the same time, only one of the master and slave can send data and the other can only receive data. In the process of serial asynchronous communication, data is sent frame by frame in the form of messages.

#### ( 3 ) Topology

Single master multi-slave system. The setting range of the slave address is 1 to 247, and 0 is the broadcast communication address. Slave addresses in the network must be unique.

### 4. Protocol description

Kd600 series inverter communication protocol is an asynchronous serial master-slave Modbus communication protocol. Only one device (host) in the network can establish a protocol (called "query/command"), other devices (slave) can only provide The data responds to the "query/command" of the host, or makes corresponding actions according to the "query/command" of the host. The host here refers to personal computer (PC), industrial control equipment or programmable logic controller (PLC), etc., and the slave refers to the KD600 inverter. The master can not only communicate with a certain slave, but also publish broadcast information to all the lower slaves. For the "inquiry/command" of the host that is accessed individually, the slave must return a message (called a response). For the broadcast information sent by the host, the slave does not need to respond to the host.

## 5. Communication frame structure

The Modbus protocol communication data format of KD600 series inverter is as follows.

Using RTU mode, message transmission starts with a pause interval of at least 3.5 character times. This is the easiest to implement with various character times at the network baud rate (as shown in T1-T2-T3-T4 in the figure below). The first field of the transfer is the device address. The transfer characters that can be used are 0...9,A...F in hexadecimal. The network device continuously detects the network bus, including the pause interval. When the first field (address field) is received, each device decodes it to determine whether it is destined for its own. After the last transmitted character, a pause of at least 3.5 character times marks the end of the message. A new message can start after this pause.

The entire message frame must be transmitted as a continuous stream. If there is a pause of more than 1.5 character times before the frame is complete, the receiving device will flush the incomplete message and assume the next byte is the address field of a new message. Likewise, if a new message follows the previous message in less than 3.5 characters, the receiving device will consider it a continuation of the previous message. This will cause an error because the value in the final CRC field cannot be correct.

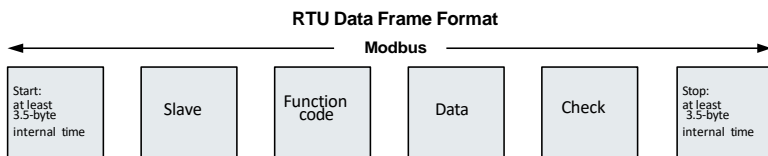

### RTU frame format:

Frame header START	3.5 character time
Slave address ADR	Communication address: 1~247 (set by P8-02)
Command code CMD	03: Read slave parameters; 06: Write slave parameters
Data content DATA (N-1)	Data content: Function code parameter address, function code parameter number, function code parameter value, etc.
Data content DATA (N-2)	
...	
Data content DATA0	
CRC CHK low order	Detection value: CRC16 check value. When transmitting, the low byte comes first and the high byte follows. For the calculation method, please refer to the description of CRC check in this section.
CRC CHK high bits	
END	3.5 character time

**Command command (CMD) and data description (DATA)**

Command code: 03H, read N words (Word), can read up to 12 words and N=1~12. The specific format is as follows:

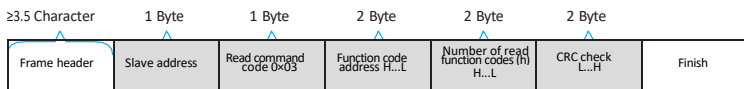
**Host read command frame**

Calculate CRC check

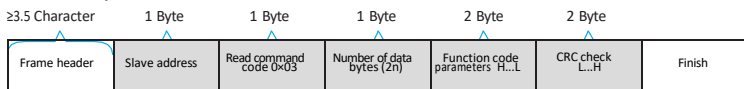
**Slave read response frame**

Calculate CRC check

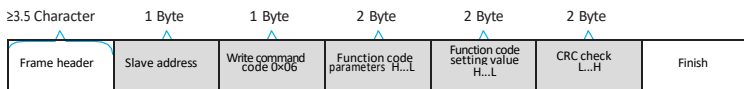
**Host write command frame**

Calculate CRC check

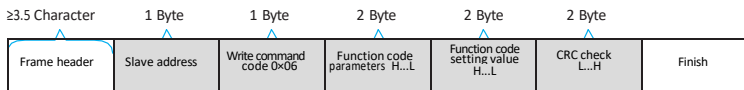
**Slave write response frame**

Calculate CRC check

If the slave detects a communication frame error, or fails to read and write due to other reasons, it will reply with an error frame. Slave read response error frame:

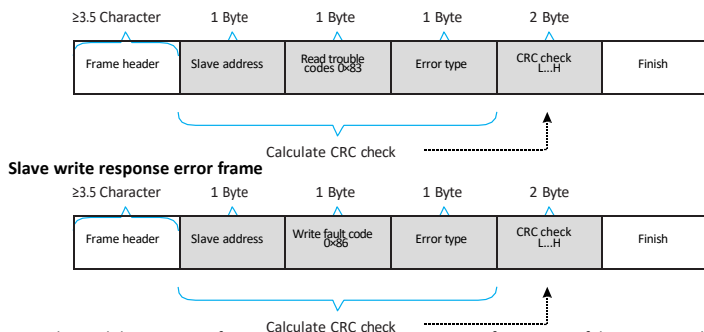

Example: read the contents of two consecutive parameters starting from P0-03 of the inverter whose slave address P8-02 is 01.

The frame sent by the host is shown in the figure:

Frame header	Slave address	Read command	Function code	Number of read	CRC check	Finish
≥3.5 Character	0x01	code 0x03	address 0x10 0x03	function codes 0x00 0x02	0x07 0x08	

The slave reply frame is as shown in the figure:

Frame header	Slave address	Read command	Data bytes	P0.03	P0.04	CRC check	Finish
≥3.5 Character	0x01	code 0x03	0x04	parameter value 0x00 0x00	parameter value 0x00 0x00	0xFA 0x33	

Note: If the write command is unsuccessful, the failure reason will be returned.

## 6. Check method (CRC check method)

CRC (Cyclical Redundancy Check) uses the RTU frame format, and the message includes an error detection field based on the CRC method. The CRC field detects the content of the entire message. The CRC field is two bytes containing a 16-bit binary value. It is calculated by the transmitting device and added to the message. The receiving device recalculates the CRC of the received message and compares it with the value in the received CRC field. If the two CRC values are not equal, it means that there is an error in the transmission.

The CRC is stored in 0xPFPF first, and then a process is called to process the consecutive 8-bit bytes in the message with the value in the current register. Only the 8-bit data in each character is valid for CRC, and the start and stop bits and parity bits are invalid.

In the process of CRC generation, each 8-bit character is XORed with the contents of the register independently, and the result is moved to the direction of the least significant bit, and the most significant bit is filled with 0. The LSB is extracted and detected. If the LSB is 1, the register is individually ORed with the preset value. If the LSB is 0, it is not performed. The whole process is repeated 8 times. After the last bit (8th bit) is completed, the next 8-bit byte is XORed with the current value of the register independently. The value in the final register is the CRC value after all bytes in the message are executed.

When the CRC is added to the message, the low byte is added first, then the high byte. The CRC simple function is as follows:

```

unsigned int crc_chk_value (unsigned char *data_value,unsigned char length) { unsigned
int crc_value=0xPFF;
int i;
while (length-->0) {
    crc_value^=*data_value++; for (i=0;i<8;i++) {
        if (crc_value&0x0001) {
            crc_value= (crc_value>>1) ^0xa001;
        }
        else {
            crc_value=crc_value>>1;
        }
    }
}
return (crc_value) ;
}

```

## 7. Address Definition of Communication Parameters

This part is the content of communication, which is used to control the operation of the inverter, the status of the inverter and the setting of related parameters.

Read and write function code parameters (some function codes cannot be changed, and are only used by manufacturers or monitored):

Function code parameter address marking rules:

The rules are represented by the function code group number and label as the parameter address:

High-order byte: P0~PF (group P), A0~AF (group A), B0~BF (group B), C0~CF (group C),

D0~DF (group D), 70~7F (group U) low byte: 00~PF Such as: P0-11, the address is expressed as F00B; Notice:

PF group: parameters can neither be read nor changed; Group U: can only be read, parameters cannot be changed.

Some parameters cannot be changed when the inverter is running; some parameters cannot be changed no matter what state the inverter is in; when changing the function code parameters, pay attention to the range, unit, and related descriptions of the parameters.

Function code group	Communication visit address	Function code address of communication change RAM
P0~PE	0xF000~0xPEPF	0x0000~0x0EPP
A0~AF	0xA000~0xAPFF	0x4000~0x4PFF
B0~BF	0xB000~0xBPFF	0x5000~0x5PFF
C0~CF	0xC000~0xCPFF	0x6000~0x6PFF
U0, U1	0x70xx, 0x71xx	

Note that, because the EEPROM is frequently stored, the service life of the EEPROM will be reduced. Therefore, some function codes do not need to be stored in the communication mode, just change the value in the RAM.

If it is a parameter of group P, to realize this function, it can be realized only by changing the high-order F of the function code address to 0.

If it is a group A parameter, to realize this function, just change the high-order A of the function code address to 4 to realize it.

The corresponding function code addresses are expressed as follows: high byte: 00~0F (group P), 40~4F (group A) low byte: 00~PF

For example, the function code P0-11 is not stored in the EEPROM, and the address is expressed as 000B; this address indicates that it can only be written to RAM, but cannot be read. When reading, it is an invalid address.

**Stop/Run parameter section:**

Address	Parameter Description
0X1000/ 0X9000	1000:*communication setting value (-10000~10000) (decimal) (unit: 0.01%), readable and writable 9000: Communication setting frequency: 0HZ~P0-14 (minimum unit: 0.01HZ), readable and writable
0x1001	Set frequency (unit: 0.01Hz), read only
0x1002	Running frequency (unit: 0.01Hz), read only
0x1003	Bus voltage (unit: 0.1V), read only
0x1004	Output voltage (unit: 0.1V), read only
0x1005	Output current (unit: 0.1A), read only
0x1006	Output power (unit: 0.1kW), read only
0x1007	DI input flag (unit: 1), read only
0x1008	DO output flag (unit: 1), read only
0x1009	PID setting (unit: 1), read only
0x100A	PID feedback (unit: 1), read only
0x100B	Ai1 voltage (unit: 0.01V), read only
0x100C	Ai2 voltage (unit: 0.01V), read only
0x100D	Ao1 output voltage (unit: 0.01V) read only
0x100E	PLC step (unit: 1), read only
0x100F	Speed (unit: 1rpm), read only
0x1010	Count value input (unit: 1), read only
0x1011	Input pulse frequency (unit: 0.01kHz), read only
0x1012	Feedback speed (unit: 0.1Hz), read only
0x1013	Remaining running time (unit: 0.1min), read only
0x1014	AI1 voltage before calibration (unit: 0.001V), read only
0x1015	AI2 voltage before calibration (unit: 0.001V), read only
0x1016	Actual linear speed (unit: 1m/min), read only
0x1017	Load speed (unit: user-defined, refer to P7-31), read only
0x1018	Current power-on time (unit: 1min), read only
0x1019	Current running time (unit: 0.1min) read only
0x101A	Input pulse frequency (unit: 1Hz), read only

Address	Parameter Description
0x101B	Main frequency X display (unit: 0.01Hz), read only
0x101C	Auxiliary frequency Y display (unit: 0.01Hz), read only
0x101D	Target torque (unit: 0.1%), Take the motor rated torque as 100%, read only
0x101E	Output torque (unit: 0.1%), Take the motor rated torque as 100%, read only
0x101F	Output torque (unit: 0.1%), Take the inverter rated current as 100%, read only
0x1020	Torque upper limit (unit: 0.1%), Take the inverter rated current as 100%, read only
0x1021	VF separation target voltage (unit: 1V), read only
0x1022	VF separate output voltage (unit: 1V), read only
0x1023	Reserved, read only
0x1024	Motor 1\2 indication (unit: 1), read only
0x1025	Length value input (unit: 1) read only
0x1026	AO2 output voltage (unit: 0.01V), read only
0x1027	Inverter status (unit: 1), read only
0x1028	Current fault (unit: 1), read only

**Example 1:** Read the operating frequency of the first device: 0x01 0x03 0x10 0x02 0x00 0x01 0x21 0x0A

0x10 0x02 (1002) operating frequency address, 0x00 0x01 (0001) a data 0x21 0x0A (210A)  
CRC check value

**Example 2:** Read the bus voltage, output voltage and output current of the first device at the same time: 0x01 0x03 0x10 0x03 0x00 0x03 CRC check value, the meaning of the data is similar to that of example 1.

**Note:** The communication setting value is a percentage of the relative value, 10000 corresponds to 100.00%, -10000 corresponds to -100.00%.

For frequency dimension data, the percentage is relative to the maximum frequency (P0-14); for torque dimension data, the percentage is P3-21, P3-23, A3-21, A3-23. **Note:** D0 output terminal needs to select 16 (communication control) function.

AO output needs to select 7 (communication control output) function.

Type	Command address	Command content
Control command input (write only)	0x2000	0001: Forward run      0002: Reverse run 0003: Forward jog      0004: Reverse jog 0005: Coast to stop    0006: Decelerate to stop    0007: Fault reset 0008: Fault reset (only in communication control mode can fault reset)
Status read (read only)	0x3000	0001: Forward running 0002: Reverse running 0003: Stop
Digital output terminal control (write only)	0x2001	BIT0: RELAY1 output control    BIT1: DO1 output control    BIT2: RELAY2 output control
Analog output AO1 control (write only)	0x2002	0~7PFF means 0%~100%
Analog output AO2 control (write only)	0x2003	0~7PFF means 0%~100%
Inverter fault address	0x8000	0000: No fault 0001: Reserved 0002: Reserved 0003: Reserved 0004: Acceleration overcurrent 0005: Deceleration overcurrent 0006: Constant speed overcurrent 0007: Stop overcurrent 0008: Acceleration overvoltage 0009: Deceleration overvoltage 000A: Constant speed overvoltage 000B: Stop overvoltage 000C: Undervoltage fault 000D: Inverter overload 000E: Motor overload    000F: Module overheat    0010: Reserved 0011: Current detection fault 0012: Reserved 0013: Reserved 0014: Motor short circuit fault to ground    0015: Motor tuning fault 0016: Reserved

Type	Command address	Command content
Inverter fault address	0x8000	0017: Input phase loss 0018: Output phase loss 0019: EEPROM read and write abnormality 001A: Password input exceeded times 001B: Communication abnormal 001C: External fault 001D: Excessive speed deviation 001E: User-defined fault 1 001F: User-defined fault 2 0020: Loss of PID feedback during runtime 0021: Hardware current limit fault 0022: Loss of load 0023: Overload fault of buffer resistor 0024: The contactor is abnormal 0025: The agent running time has arrived 0026: Motor over temperature (reserved) 0027: Current running time reached 0028: Cumulative running time reached 0029: Power-on time reached 002A: Switching motor failure during operation 002B: Motor overspeed 002C: Reserved 002D: Reserved 002E: reserved 002F: point-to-slave fault

The return address when communication fails: read fault 83XX, write fault 86X.

## Appendix B: Introduction to Expansion Card

### Quick selection List

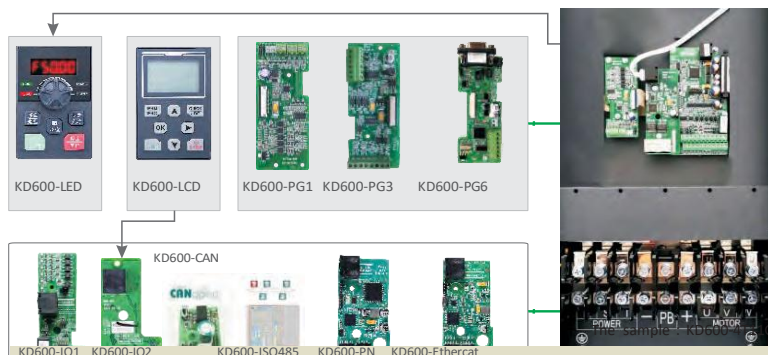

Type	Model	The order code	Use
I/O expansion card 1	KD600-IO1	5 digital input, one relay output, one analog AO2 output, one digital Y2 output, one temperature detection (PT100/PT1000/PTC/KTY).	The same 28-bit pin port is connected to the mainboard
I/O expansion card 2	KD600-IO2	Two digital input, one relay output, one analog AO2 output, one LCD expansion network port RJ45 socket.	
CANOPEN communication expansion card	KD600-CANOPEN	CANOPEN communication expansion card	
ProFinet communication card	KD600-PN	—	
Profbus - DP communication card	KD600-DP	—	
Ethercat communications card	KD600-Ethercat	—	

Type	Model	The order code	Use
Collector open ABZ encoder card	KD600-PG1	Open collector PG card (PG card 1 can only be used in asynchronous machine; Compatible with complementary output, encoder card output DC power supply can be +12V or +5V (jumper selection) Suitable for asynchronous tractor closed-loop Vector Control (VC)	The same 18-bit interface is wired to the mainboard
Differential input ABZ encoder card	KD600-PG3	ABZ differential signal input PG card; 1:1 differential frequency division output Suitable for asynchronous tractor closed-loop Vector Control (VC)	
Sine and cosine encoder card	KD600-PG5	Support sine and cosine signal input; Support differential frequency division output; Closed-loop Vector Control (VC) for synchronous tractors	
Rotary transformer interface card	KD600-PG6	Suitable for rotary transformer, DB9 interface, optional shielded encoder line. Closed-loop Vector Control (VC) for synchronous tractors	
LCD keyboard	KD600-LCD	Extended LCD keyboard (must support IO extension or communication extension)	Used with the expansion board

### Instructions:

- Extended function models are KD600 series 4.0KW and above models. 2.2KW and below No expansion function;
- Default voltage level of adaptor converter is 380V to 480V, 660V-690V, three-phase. For details, contact our technical personnel.

## Installation and function description of expansion card

### Installation of expansion card

KD600 series inverter is equipped with 2 I/O expansion cards, 4 field bus cards (Profibus-DP, CANopen, Profinet, EtherCAT) and 54 kinds of PG cards. The installation positions are shown in the following figure. The cover plate needs to be removed during installation (refer to the following figure for installation).

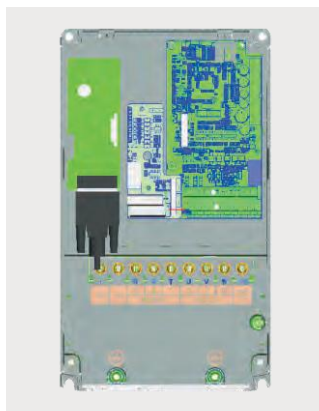

KD600 series 11kw and above model expansion diagram

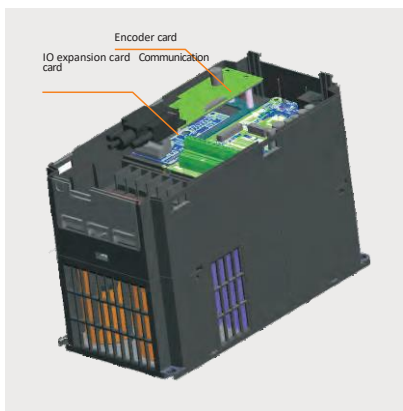
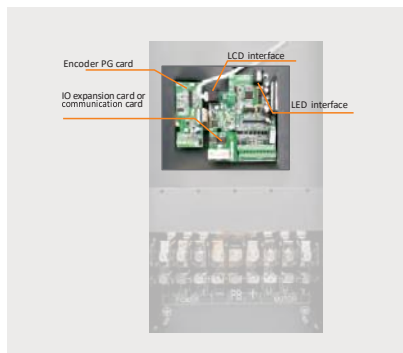

Diagram of the 4.0KW-9.0KW expansion mode Models of 2.2KW and below have no expansion function



Installation Diagram of 4.0KW-9.0KW Expansion Interface



Physical installation drawing of 11KW and above models

## 1 I/O expansion card

### 1.1 I/O expansion card 1

#### 1.1.1 Product Overview

KD600-IO1 expansion card is an I/O expansion card designed for supporting KD600 series inverter. It can expand 5 DI, 1 AI, 1 DO, 1 AO and 1 relay output, and one temperature detection.

#### 1.1.2 Appearance and Size



Figure 1-1 Appearance of I/O expansion card 1

#### 1.1.3 Interface layout and description

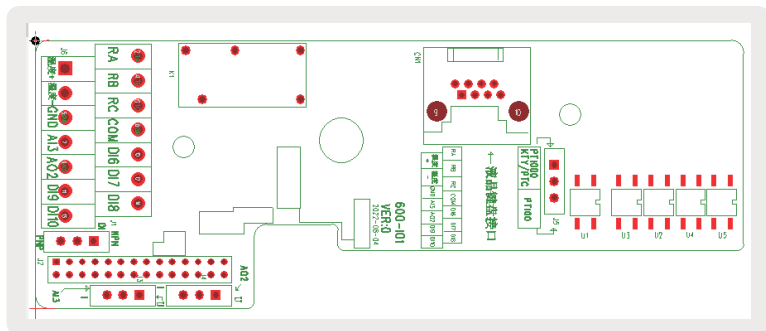
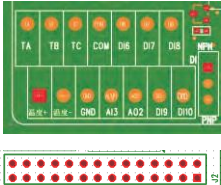
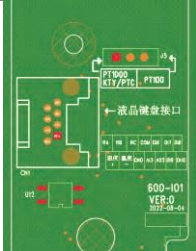

Figure 1-2 I/O expansion card 1 interface layout

I/O expansion card 1 terminal function description

Terminal identity	The name of the terminal	Functional specifications	Terminal distribution
TA-TB	Normally closed contacts	Contact drive capability: AC250V, 3A, $\text{COS}\Phi=0.4$ .	
TA-TC	Often beginning son	DC 30V, 1 A	
COM	+24V power supply common terminal	+24V power supply common terminal	
DI6	DI6-COM~DI10-COM	<ol style="list-style-type: none"> <li>Optical coupling isolation, compatible with bipolar input (PNP input, +24V power connected to the motherboard +24V);</li> <li>Input impedance: 4.4k<math>\Omega</math>;</li> <li>Level input voltage range: 9~30V.</li> </ol>	
AO2-GND	Analog output	<ol style="list-style-type: none"> <li>Output voltage specifications: 0V ~10V;</li> <li>Output current: 0mA~20mA;</li> <li>Output current with impedance: 0<math>\Omega</math> to 500<math>\Omega</math>.</li> </ol>	
TEMP-P ; TEMP-N	Temperature plus, temperature minus	Pt100, PT1000 temperature sensor, PTC, KTY type temperature sensor	
AI3-GND	Analog input terminal AI3	Input voltage range: 0 ~ 10V (input impedance: 30k $\Omega$ ); Input current range: 0 to 20mA (input impedance: 500 $\Omega$ ).	
J2	Motherboard connection	28 bit pin connected to the main control board	
CN1	Liquid crystal keyboard port	After the LCD keyboard is connected, the digital tube keyboard can be displayed, but not operated.	

Terminal identity	The name of the terminal	Functional specifications	Terminal distribution
J4	AO2 Output type Set jumper	Short cap Short U: indicates the voltage-type output Short-circuit I: Current output	
J1	NPN/PNP Enter DI to select a type jumper	DI6-DI10 Indicates the input type.NPN type, PNP type	
J3	AI3 Analog input type Set jumper	Short cap Short U: indicates the voltage type Short-circuit cap Short-circuit I: Current type	

### Instructions:

When the DIP switch is set, the top view of the expansion card with the main terminal as the bottom side is used as the viewing Angle. In addition, the DIP switch is printed on the board, and the silk screen is used as the standard.

## 1.2 I/O expansion card 2

### 1.2.1 Appearance and Size

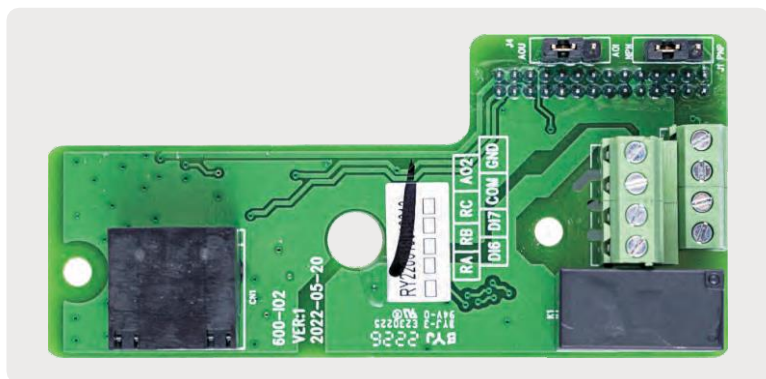

Figure 1-3 Appearance of I/O expansion card 2

## 1.2.2 Interface layout and description

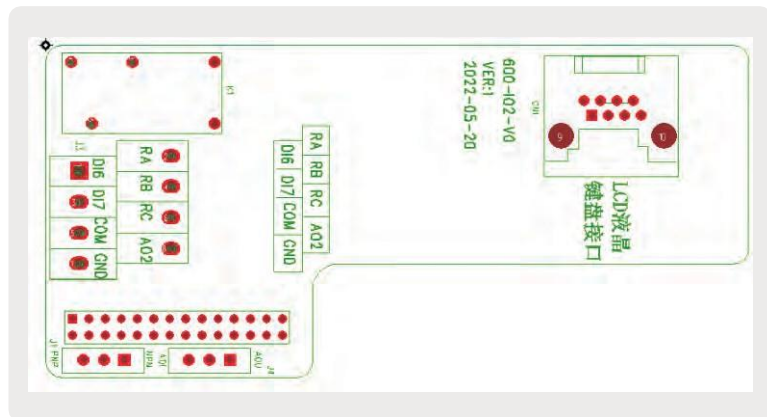
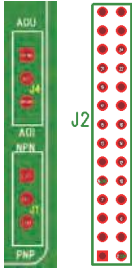

Figure 1-4 I/O expansion card 2 interface layout I/O expansion card 2 terminal function description

Terminal identity	The name of the terminal	Functional specifications	Terminal distribution
RA-RB	Normally closed contacts	Contact drive capability: AC250V, 3A, $\cos\phi \leq 0.4$ .	
RA-RC	Often beginning son	DC 30V, 1 A	
COM	+24V power supply common terminal	+24V power supply common terminal	
DI6~DI7	DI6-COM DI10-COM	<ol style="list-style-type: none"> <li>Optical coupling isolation, compatible with bipolar input (PNP input, +24V power connected to the motherboard +24V);</li> <li>Input impedance: 4.4k<math>\Omega</math>;</li> <li>Level input voltage range: 9~30V.</li> </ol>	
AO2-GND	Analog output	<ol style="list-style-type: none"> <li>Output voltage specifications: 0V ~10V;</li> <li>Output current: 0mA~20mA;</li> <li>Output current with impedance: 0<math>\Omega</math> to 500<math>\Omega</math>.</li> </ol>	

Terminal identity	The name of the terminal	Functional specifications	Terminal distribution
J1	NPN/PNP Enter DI to select a type jumper	DI6-DI10 Indicates the input type. NPN type, PNP type	 <p>The diagram shows a vertical 28-pin connector labeled J2. The pins are arranged in two columns of 14. The top pin is labeled ADJ. The next two pins are labeled AO2. The next two pins are labeled PNP. The bottom pin is labeled PNP. The pins are represented by red circles, with the bottom-most pin being a red square.</p>
J4	AO2 Output type Set jumper	Short cap Short U: The output voltage ranges from 0 to 10V Short-circuit cap Short-circuit I: The current output ranges from 4mA to 20mA	
J2	Motherboard connection	28 bit pin connected to the main control board	

### Instructions:

- When the DIP switch is set, the top view of the expansion card with the main terminal as the bottom side is used as the viewing Angle. In addition, the DIP switch is printed on the board, and the silk screen is used as the standard.

## 2 Communication expansion card

### 2.1 ProFinet communication card

#### 2.1.1 Product Overview

KD600-PN card is Profinet field bus adapter card, in line with the international communication Profinet Ethernet standard. The card is installed on the KD600 series inverter to improve the communication efficiency and realize the networking function of the inverter, so that the inverter becomes the slave station of the fieldbus and accepts the control of the fieldbus master station.

#### 2.1.2 Appearance and Size



Figure 2-1 Appearance of ProFinet communication card

#### 2.1.3 Interface layout and description

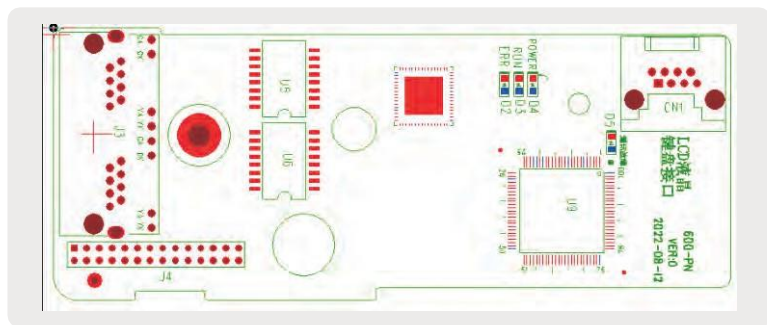
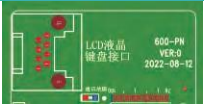

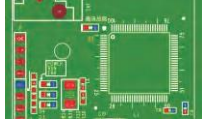

Figure 2-2 Layout of ProFinet Communication Card Interface

ProFinet Communication Card Terminal Function Description

Terminal identity	The name of the terminal	Functional specifications	Terminal distribution
CN1	LCD keyboard interface	LCD liquid crystal interface	
J3	Double network port connector	Any network port terminal can be connected to the near PLC end	
J4	28-bit pin row plug	Connect to frequency converter motherboard	
LED	Indicator light	POWER power indicator RUN the light ERR Error indicator Communication fault indicator light	

### Instructions:

When the DIP switch is set, the top view of the expansion card with the main terminal as the bottom side is used as the viewing Angle. In addition, the DIP switch is printed on the board, and the silk screen is used as the standard.

## 2.2 Profbus-DP communication card

### 2.2.1 Product Overview

The Profbus-DP communication card (hereinafter referred to as the DP expansion card) is a PROFIBUS-DP fieldbus adapter card, which complies with the international Profibus standard. The PROFBUS-DP communication card can improve the communication efficiency on the frequency converter, realize the networking function, and make the frequency converter become the slave station of the fieldbus and accept the control of the master station of the fieldbus. This DP expansion card can realize Profibus-DP communication.

Type	Profbus-DP
Diagnostic support	Support
DPV1 support	Support

Type	Profibus-DP
PPO4 support	Support
PPO Type Selection	Siemens Background Setting
PZD Mapping address	Siemens Background Setting
Set dip switch for station number	The value ranges from 1 to 125
The main out standing	The expansion card actively informs the converter
Communication rate between card and converter	Fixed rate
From the stand failure	LCD liquid crystal interface
CAN communication support	Any net

## 2.2.2 Appearance and Size



Figure 2-3 Appearance of the Profibus-DP communication card

## 2.2.3 Interface layout and description

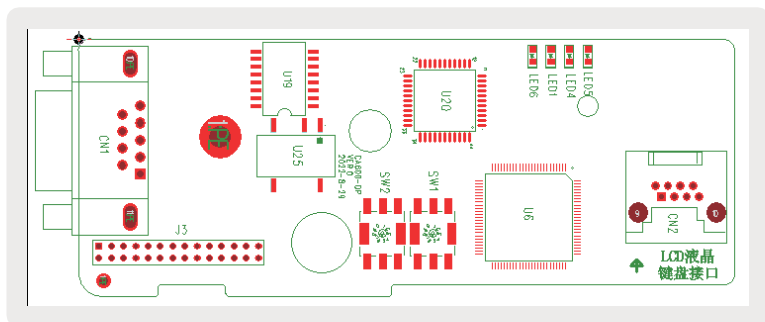

Figure 2-4 Layout of Profibus DP communication card interface

Function Description of Ethercat Communication Card Terminal

Terminal identity	The name of the terminal	Functional specifications
CN1	DB9 plug	DP communication interface
J3	28 position flat pin contact pin	Connected to inverter mainboard
Cn2	LCD keyboard network cable interface	Connect the LCD keyboard network cable interface

### Instructions:

Dial setting is to use the top view of the expansion card with the main terminal as the bottom as the viewing angle. In addition, the dial has a silk screen on the board. Please use the silk screen as the standard.

## 2.3 Ethercat communications card

### 2.3.1 Product Overview

SI-ECAT card can be used in industrial field level ultra-high speed I/O network, protocol processing directly to the I/O layer, has the advantages of high efficiency, flexible topology and easy operation.

### 2.3.2 Appearance and Size



Figure 2-5 Appearance of Ethercat communication card

## 2.3.3 Interface layout and description

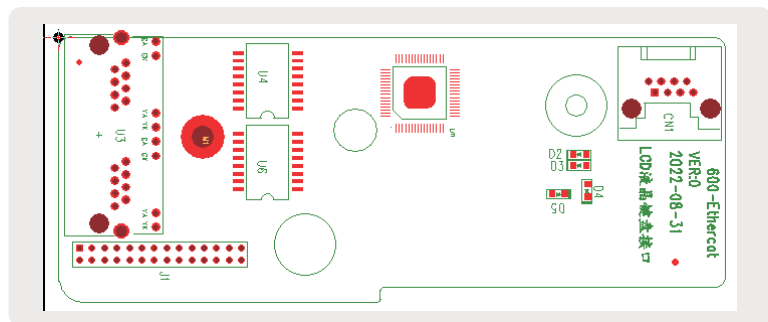

Figure 2-6 Layout of Ethercat Communication Card Interface

The EtherCAT communication expansion card (SI - ECAT) uses a standard Ethernet RJ45 socket, which is connected to the EtherCAT master station. Its pin signal definition is consistent with the standard Ethernet pin, and both cross and direct lines can be used.

Function Description of Ethercat Communication Card Terminal

Terminal identity	The name of the terminal	Functional specifications
U3	Input port/output port	In order to ensure the working stability, please select Category V shielded twisted pair network cable.
J1	28 position flat pin contact pin	Connected to inverter mainboard
CN1	Rj45 LCD keyboard interface	Connect the LCD keyboard network cable interface

**Instructions:**

Installation setting is to use the top view of the expansion card with the main terminal as the bottom as the viewing angle. In addition, the dial has a silk screen on the board. Please use the silk screen as the standard.

### 3 Encoder class expansion card

#### Encoder card wiring requirements:

- ❑ Cable of encoder card must be routed separately from the power cable, and it is strictly prohibited to route in parallel at a short distance.
- ❑ Use shielded cable for routing encoder card. The shielding layer is connected to PE terminal at the side close to the controller (only one end can be grounded to avoid interference).
- ❑ Encoder card must be routed through the tube separately, and the metal tube shell must be reliably grounded.

#### 3.1 Open collector ABZ encoder card (KD600-PG1)

##### 3.1.1 Product Overview

ABZ open collector signal input, with 1:1 frequency split open collector signal output encoder card.

##### 3.1.2 Appearance and Size

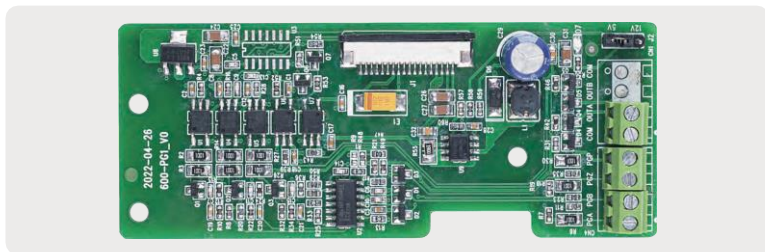
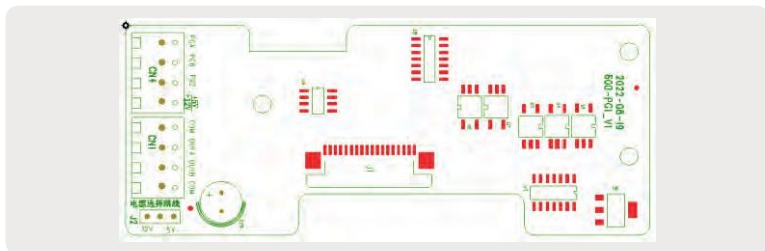

Figure 3-1 Appearance of KD600-PG1 collector open circuit ABZ encoder card



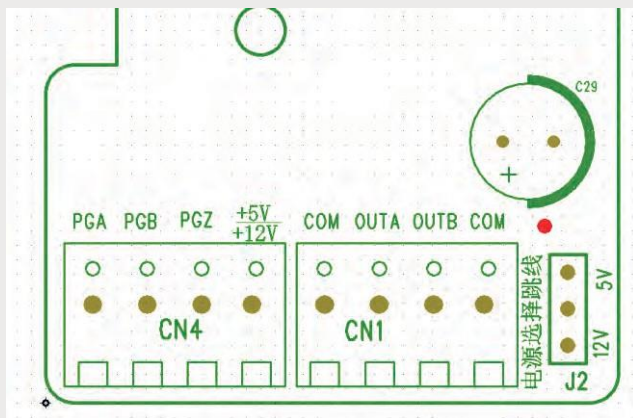

Figure 3-2 KD600-PG1 collector open circuit ABZ encoder card interface layout

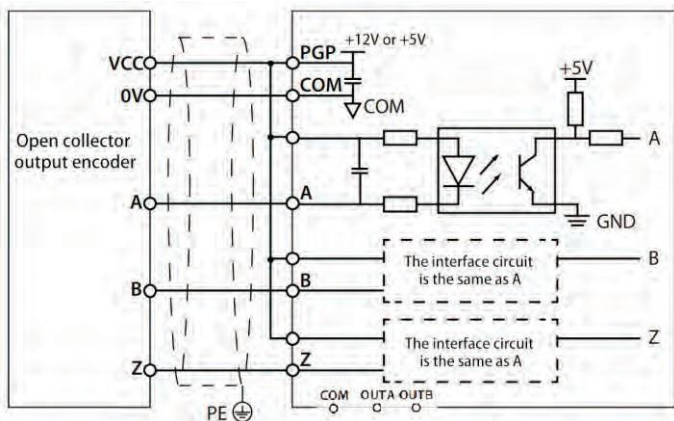

Figure 3-3 Collector open ABZ encoder card wiring diagram

Terminal identity	The name of the terminal	Functional specifications
J1	Control signal connection port	Connect the mainboard encoder port
CN1	PGA,PGB,PGZ: ABZ signal input port of the encoder	The encoder A
	PGP(+5V,+12V)+12V or +5V power output	Select +12V or +5V through the J2 jumper
CN4	COM	Grounding
	OUTA	Frequency division output A signal, NPN OC output
	OUTB	Frequency division output B signal, NPN type OC output

### Instructions:

When the DIP switch is set, the top view of the expansion card with the main terminal as the bottom side is used as the viewing Angle. In addition, the DIP switch is printed on the board, and the silk screen is used as the standard.

## 3.2 Differential input ABZ encoder card (KD600-PG3)

### 3.2.1 Appearance and Size



Figure 3-4 Appearance of KD600-PG3 differential input ABZ encoder card

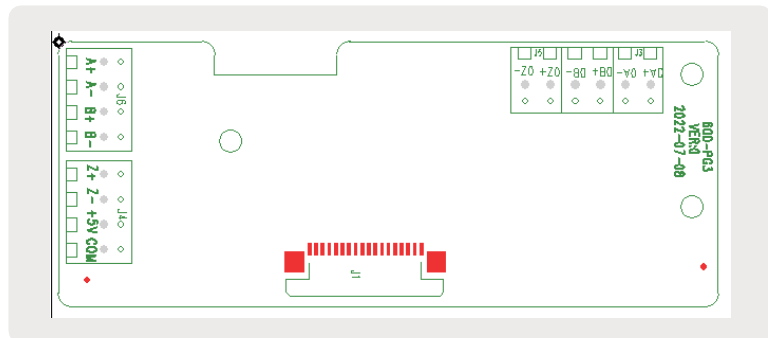

Figure 3-5 KD600-PG3 Differential Input ABZ Encoder Card Interface Layout

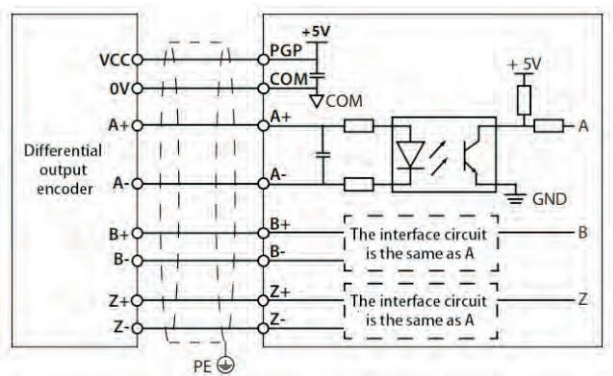

Figure 3-6 Differential output ABZ encoder card wiring diagram

Differential input ABZ encoder card terminal function description

Terminal identity	The name of the terminal	Functional specifications
J1	Control signal connection port	Connect the mainboard encoder port
J4,J6	A+,A-	Encoder A+/A- signal
	+5V,COM	+5V power output
	B+,B-	Encoder B+/B- signal
	Z+,Z-	Encoder Z+/Z- signal

Terminal identity	The name of the terminal	Functional specifications
J3,J5	OA+,OA-	Frequency division output differential A signal
	OB+,OB-	Frequency division output differential B signal
	OZ+,OZ-	Frequency division output differential Z signal

### Instructions:

Dial setting is to use the top view of the expansion card with the main terminal as the bottom as the viewing angle. In addition, the dial has a silk screen on the board. Please use the silk screen as the standard.

## 3.3 Rotary transformer interface card (KD600-PG6)

### 3.3.1 Appearance and Size

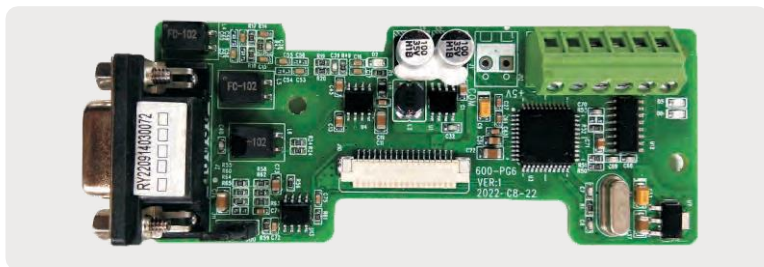

Figure 3-7 KD600-PG6 resolver interface card appearance

### 3.3.2 Interface layout and description

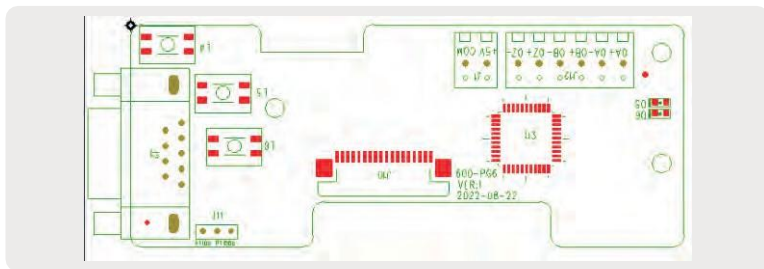

Figure 3-8 KD600-PG6 resolver interface card interface layout

This section describes the functions of the terminals of the rotary transformer interface card

Terminal identity	The name of the terminal	Functional specifications
J2	EXC-,EXC+	Encoder excitation output signal, 4Vrms/10kHz sinusoidal signal
	SIN+,SIN-	Encoder feedback input signal, 2Vrms/10kHz positive rotation, SIN signal is 90° ahead of COS signal When reversed, the COS signal leads the SIN signal by 90°
	COS+,COS-	
J12	OA+,OA-	1:1, ABZ differential signal output (0-500KHz)
	OB+,OB-	
	OZ+,OZ-	
J2	PTCP	Motor temperature detection :PT100,PT1000,KTY,PTC, etc
	PTCN	
J1	+5V,COM	+5V power supply
J10	Control signal cable interface	Connect the mainboard encoder port

### 3.3.3 EXC/SIN/COS signal description

The excitation signal (EXC) and feedback signal (SIN/COS) waveforms of the rotary transformer encoder card are shown in the following figure.

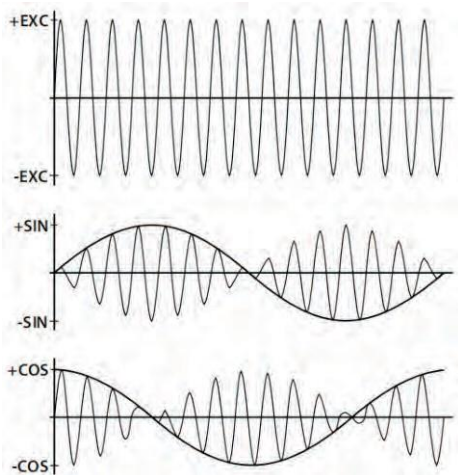

### 3.3.4 Accessories: rotary encoder wire can be selected by users

The encoder line	DB9 pin number	1	2	3	4	5	9	7	8	Metal case
	Line color	red	black	orange	purple	blue	green	gray	white	Yellow and green heat shrink tubing
	Define	EXC+	EXC-	SIN+	SIN-	COS+	COS-	PTC-M	PTC-N	Ground (imported)
		twisted-pair		twisted-pair		twisted-pair		twisted-pair		Answer the shield
External lead (with definition label)								gray	white	

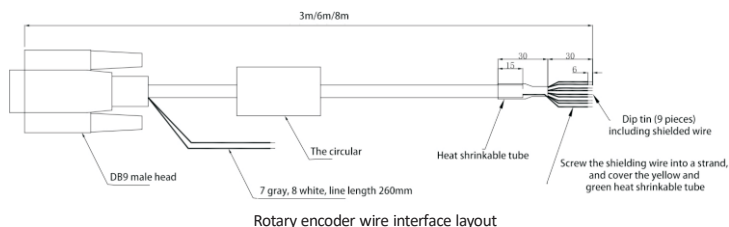

#### Instructions:

- When the DIP switch is set, the top view of the expansion card with the main terminal as the bottom side is used as the viewing Angle. In addition, the DIP switch is printed on the board, and the silk screen is used as the standard.

## 3.4 Sine cosine encoder interface card (KD600-PG5)

### 3.4.1 Appearance and Size



Figure 3-9 External view of resolver interface card

### 3.4.2 Interface layout and description

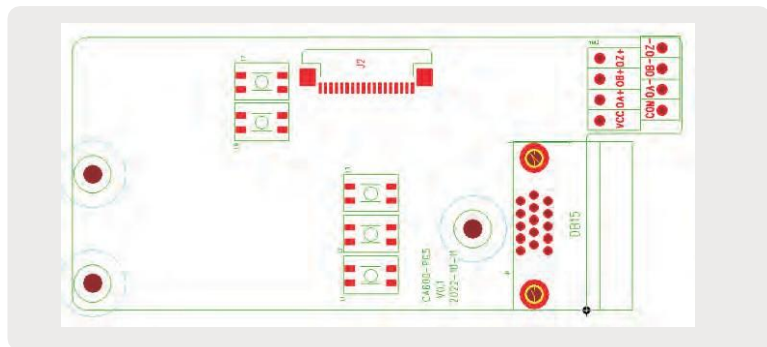

Figure 3-10 Function Description of Rotary Transformer Interface Card Terminal

#### Terminal description

Terminal		Signal description
1/8	B-/B+	Encoder differential signal B -/B+
3/4	R+/R-	Encoder differential signal R -/R+
5/6	A+/A-	Encoder differential signal A -/A+
7	PG/GND	Power supply ground
9	PG/VCC	+5V power supply
10/11	C+/C-	Encoder differential signal C+/C-
12/13	D+/D-	Encoder differential signal D+/D-
12/14/15		NA
	OA+,OA-	Frequency division output differential A signal
	OB+,OB-	Frequency division output differential B signal
	OZ+,OZ-	Frequency division output differential Z signal

### 3.4.3 Encoder card wiring

It is recommended to use the Heidelberg ERN1387 encoder. The double row socket of 1387 corresponds to the DB15 terminal block as shown in the table:

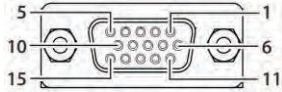
1387 double row socket		DB15 terminal block															
<table border="1"> <tr> <td>1b</td><td>2b</td><td>3b</td><td>4b</td><td>5b</td><td>6b</td><td>7b</td> </tr> <tr> <td>1a</td><td>2a</td><td>3a</td><td>4a</td><td>5a</td><td>6a</td><td>7a</td> </tr> </table>		1b	2b	3b	4b	5b	6b	7b	1a	2a	3a	4a	5a	6a	7a		
1b	2b	3b	4b	5b	6b	7b											
1a	2a	3a	4a	5a	6a	7a											
5a	B-	1	B-														
4b	R+(Z+)	3	R+														
4a	R-(Z-)	4	R-														
6b	A+	5	A+														
2a	A-	6	A-														
3a+5b	0V	7	PGGND														
3B	B+	8	B+														
7b+1b	+5V	9	PGVCC														
7b	C+(SIN-)	10	C+														
1a	C-(SIN+)	11	C-														
2b	D+(COS+)	12	D+														
6a	D-(COS-)	13	D-														

## Appendix C: Detailed description of expansion card

### 1 EtherCAT expansion card details

#### 1.1 Introduction

The KD600-EA card is an EtherCAT fieldbus adapter card, which can be used in ultra- high speed I/O networks. This protocol is applicable to the I/O layer. The card has high efficiency, flexible topology and easy operation. It is installed in CA series AC drives to increase communication efficiency and realize the networking function of AC drives. The AC drives are controlled by the fieldbus master station. The KD600-EA card can be used for CA series AC drives, such as the KD600. The KD600-EA card software version required in this user guide is 1.00 or above (parameters on the AC drive after the card is installed and powered on). The corresponding XML file is KD600\_EC.xml. This user guide applies only to KD600 series AC drives. If you need to use the KD600-EA card on other AC drives, please contact our technician engineer to check whether it is available and obtain the appropriate information.

Please read this user guide carefully before using this product.



Figure 4-1 KD600-EA Card Appearance

#### 1.2 Installation and setup

##### 1.2.1 Installing the KD600-EA Card

The KD600-EA card is installed in the KD600 series AC drive. Before installation, disconnect the power supply of the AC drive and wait for about 10 minutes until the charging indicator on the AC drive lights up. Then, insert the KD600-EA card into the AC drive and tighten the screws to avoid damage caused by the tension of the external signal cable on the inter board signal socket. Figure 4-2 shows the installation.

**NOTE:**

■KD600-EA card and the grounding terminal of the AC driver must be connected, as shown in Figure 4-3.

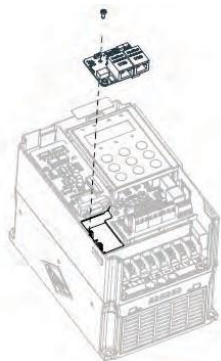

Figure 4-2 Installation of KD600-EA card

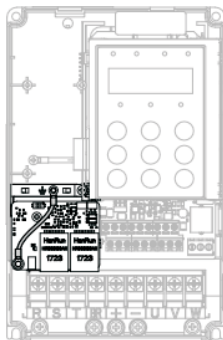

Figure 4-3 Ground terminal connection between KD600-EA card and AC driver

Figure 4-3 Ground terminal connection between KD600-EA card and AC driver 2.2 Hardware layout

Figure 4-4 shows the hardware layout of the KD600-EA card. The pin J1 on the back is used to connect the AC drive. The KD600-EA card provides two network ports U3 for communication with the master station (or the previous slave station) and the next slave station (if any). See Table 4-1 for hardware details.

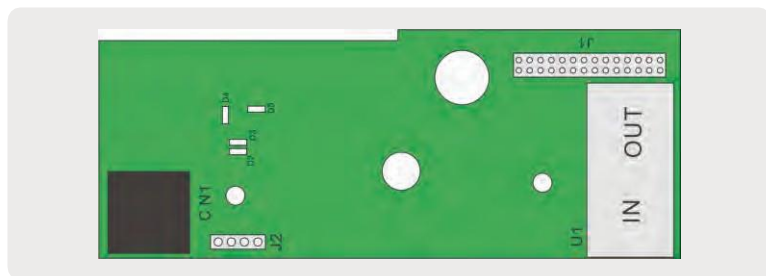

Figure 4-4 KD600-EA card (hardware)

Table 4-1 Hardware Description of KD600-EA Card

Symbol	Hardware name	Function description
J1	Pin connector	Used to connect AC drives
U1	Network port	It is used to communicate with the master station (or previous slave station) and the next slave station (if any). The left one is for input, and the right one is for output.
CN1	Keyboard interface	LCD keyboard interface
D2	Ethercat Op status indicator (green)	See Table 4-2 for the indicator of KD600- EA card.
D3	Inverter communication indicator (green)	
D4	Power indicator (green)	
D5	Ethercat fault indicator (red)	

Table 4-2 Index description of KD600-EA card

Indicating signal	Status Description	Solution
D2	Green is always on	Working in OP state N/A
	Blinking green	Working/safety mode in PREOP Check the configuration. Check that the AC drive supports the KD600-EA card and that F8-11 is set to 1. Check that the network port is properly connected.
	OFF status	Disconnect or work in initial mode Check whether the master station and the network port are connected correctly.
D3	Green is always on	Normal N/A
	OFF status	Lost communication with the drive Set P8-11 to 1 and check if the AC drive supports the KD600-EA card.
D4	Green is always on	Normal N/A
	OFF status	Communication board is not powered on Check whether J1 connector is connected normally and whether the frequency converter is powered on.
D5	OFF status	Normal N/A
	Red is always on	ESC internal failure Please contact technical support.

### 1.2.2 EtherCAT RJ45 interface

The KD600-EA card is connected to the RJ45 socket of the EtherCAT master station using standard Ethernet. The pin signal definition is the same as the standard Ethernet pin. They can be connected using cross cable or straight through cable.

Table 4-3 EtherCAT Communication Interface Description

Symbol	Hardware name	Function description
U1	ECAT IN	Network interface. The left side is for input, and the right side is for output.
CN1	ECAT OUT	

**NOTE:**

- ✎ installing the KD600-ECAT card, the ECAT IN is on the left side and the ECAT OUT is on the right side when facing the RJ45 interface. The two interfaces must be connected correctly.
- ✎ facing RJ45 interface. The two interfaces must be connected correctly. Cat5e shielded twisted pair (STP) network cables must be used to ensure stability.

**1.3 Communication configuration****1.3.1 Signal communication**

Communication configuration of KD600-EA card and KD600 AC After installing KD600-EA card on KD600 series AC driver, complete communication configuration to realize communication between them.

**■ Communication card settings for AC drives**

The following parameters must be set in order to connect the KD600-EA card to the EtherCAT fieldbus network and the KD600 series AC drive.

-23-

Function code	Name	Description (setting range)	Factory Default	Change
P0-04	Run command source	0: Operation panel running command channel (LED off) 1: Terminal command channel (LED on) 2: Communication command channel (LED flashes)	2	Running command issued by communication
P0-06	Main frequency source X selection	0: Up/Down modification frequency, no memory after shutdown 1: Up/Down modification frequency power-off memory 2: AI1 3: AI2 4: Multi-speed 5: Simple PLC	7	The given target frequency is communicated

Function code	Name	Description (setting range)	Factory Default	Change
P0-06	Main frequency source X selection	6: PID 7: Communication given 8: PULSE pulse setting 9: Up/Down modifies the frequency, and the memory is stopped when the power is turned off.	7	The given target frequency is communicated
p8-11	Serial communication protocol	0: Modbus protocol 1: Communication Card Bridge Protocol	1	Select special item communication card for communication

### Parameters related to communication control

Name	Description (setting range)	Index	Sub-index
Written Freq	Communication setting frequency: 0Hz~ P0-14 (minimum unit: 0.01Hz)	16#2073	16#01
Control command	0001: Forward running 0002: Reverse operation 0003: positive inching 0004: Reverse inching 0005: Free stop 0006: Deceleration shutdown 0007: Fault reset 0008: Fault reset (only in -control mode)	16#2073	16#02
DO	BIT0: RELAY1 output control BIT1: DO1 output control BIT2: RELAY2 output control	16#2073	16#03
A01	0~7FFF means 0%~100%	16#2073	16#04
A02	0~7FFF means 0%~100%	16#2073	16#05

### AC drive parameters (common)

Function code	Name	Description (setting range)	Index	Sub-index
P0-14	Maximum output frequency	When P0-20=1, the adjustable range is 50.0Hz~1200.0Hz; When P0-20=2, the adjustable range is 50.00Hz~600.00Hz;	16#20F0	16#0A

Function code	Name	Description (setting range)	Index	Sub-index
P0-14	Maximum output frequency	When P0-20=1, the adjustable range is 50.0Hz~1200.0Hz; When P0-20=2, the adjustable range is 50.00Hz~600.00Hz;	16#20F0	16#0A
P0-21	Acceleration and deceleration time unit	0: 1 second 1: 0.1 seconds 2: 0.01 seconds	16#20F0	16#13
P0-23	Acceleration time 1	0s~30000s(P0-21=0) 0.0s~3000.0s(P0-21=1) 0.00s~300.00s(P0-21=2)	16#20F0	16#11
P0-24	Deceleration time 1	0s~30000s(P0-21=0) 0.0s~3000.0s(P0-21=1) 0.00s~300.00s(P0-21=2)	16#20F0	16#12
P7-00	Jog running frequency	0.00Hz~Maximum frequency	16#20F7	16#01
P7-01	Jog acceleration time	0.0s~3000.0s	16#20F7	16#02
P7-02	Jog deceleration time	0.0s~3000.0s	16#20F7	16#03
PD-01	Torque digital given	-200.0%~200.0%	16#20FD	16#03
PD-03	Torque control positive direction maximum frequency	0.00Hz~Maximum frequency (P0-14)	16#20FD	16#04
PD-04	Torque control reverse direction maximum frequency	0.00Hz~Maximum frequency (P0-14)	16#20FD	16#05
U1-05	Output power (KW)	0.1kW	16#2070	16#06
U1-06	DI input status, hexadecimal number	1	16#2070	16#07
U1-07	DO output status, hexadecimal number	1	16#2070	16#08

AC drive parameter indicators are described as follows:

Each object in the dictionary shall be uniquely addressed by using an index and sub-index.

"Index": This field (hexadecimal) specifies objects of the same type in the dictionary.

"Sub index": this field specifies the overall arrangement of offsets for each object in the same index in hexadecimal

The mapping between AC drive parameters and object dictionary is as follows: Object dictionary index=0x2000+parameter group number

Object dictionary sub index=hexadecimal+1 of offset in parameter group.

By default, when using the KD600-EA card, the PDO1 and PDO2 written are mapped to U3-17 and U3-16. Therefore, the first item of RPDO must be U3-17; Otherwise, the operation will be abnormal. In addition, if the eight high bits of U3-17 are written with any non-zero value, the AC driver will report a communication failure (Err16).

### 1.3.2 Communication settings between KD600-EA card and EtherCAT host

After enabling the communication between the KD600-EA card and the KD600 AC drive, connect the EtherCAT master station to correctly enable the networking function between the communication card between the KD600-EA and the EtherCAT master station and the AC drive.

#### A: EtherCAT topology

EtherCAT supports various topologies, including star, bus and tree topologies, and their combinations. This makes equipment connection and wiring flexible and convenient. This figure shows the bus topology.

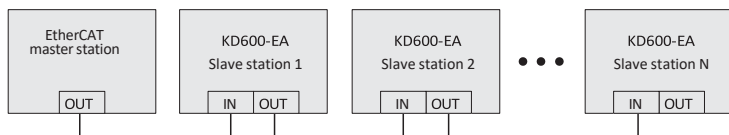

Table 4-5 Bus topology

#### B: EtherCAT communication protocol

In DC mode, the cycle of DC synchronization mode must be at least 1ms, but less than 100ms. Otherwise, an EtherCAT communication failure will occur.

##### ■ PDO data description

PDO data is used by the master station to modify and read AC drive data in real time to perform regular data exchange. The data communication address is AC driven. It mainly includes:

- a) Real time setting of AC drive control command and target frequency ;
- b) Real time reading of AC drive current status and operating frequency ;

c) The process data of the functional parameters and monitoring data in the AC drive and the PDO of the EtherCAT master station are used for the regular data exchange between the master station and AC, as described in the following table.

Primary sending PDO (0x1600)		
Fixed RPDO		Variable RPDO
AC drive target frequency	AC drive command	Modify the functional parameters of the frequency converter
RPDO1	RPDO2	RPDO3 to RPDO10
Corresponding AC drive data PDO (0x1A00)		
AC drive status	AC drive operating frequency	Read the functional parameters of the AC drive
TPDO1	TPDO2	TPDO3 to TPDO10

**Note:** Up to 10 RPDOs and 10 TPDOs can be configured.

#### ■ Data sent by master station

Primary sending RPDO	
RPDO1	<p>The AC drive target frequency (the frequency source is set as "communication") is within the range from the upper limit of the reverse frequency (negative value) to the upper limit of the forward frequency (including the decimal point, for example, 2000 corresponds to 20.00 Hz on the AC drive). When the given target frequency exceeds the range, the AC drive operates at the upper limit of the frequency.</p> <p>For example, if the upper frequency limit is set to 50.00 Hz and set to 6000, the AC drive will operate in the forward direction at 50.00 Hz. If the upper frequency limit is set to 50.00 Hz and the communication is set to - 6000, the AC drive will operate in reverse at 50.00 Hz.</p>
RPDO2	<p>AC drive command word (command source is set to "communication")</p> <p>0001: Forward running            0002: Reverse operation            0003: positive inching            0004: Reverse inching            0005: Free stop            0006: Deceleration shutdown            0007: Fault reset            0008: Fault reset (only in communication control mode)</p>
RPDO3 TO RPDO10	Real time modification of function parameter values (Group F and Group A) without writing into EEPROM (electronic read-only memory)

### ■ Data sent by master station

Corresponding AC drive data TPDO	
TPDO1	Operation status of AC drive
	0001: Forward running 0002: Reverse operation 0003: Shutdown
TPDO2	Operating frequency (unit: 0.01Hz)
	Returns the current AC drive operating frequency. The returned data is 16 bit signed and the received data is 16 bit unsigned data. Variables must be mapped to 16 bit signed data.
TPDO3 TO TPDO10	Read function parameter values (Group F and Group A) and monitor parameter values (Group U)

For more information about PDO definitions for other AC drives, see the appropriate AC drive user guide.

### ■ Service Data Object (SDO)

EtherCAT SDO is used to transmit acyclic data, such as communication parameter configuration and servo driver operation parameter configuration. EtherCAT CoE service types, including:

- 1) Key event messages
- 2) SDO request
- 3) SDO response 4
- 4) TxPDO
- 5) RxPDO
- 6) Remote TxPDO sends request
- 7) Remote RxPDO sends request
- 8) SDO information

Currently, AC drives support SDO requests and responses. For detailed SDO parameters, see the KD600 User Guide.

### 1.3.3 Use KD600-EA card with Beckhoff controller

Taking the TwinCAT master station of Beckhoff as an example, the MD500-ECAT card is described.

#### Note:

100M Ethernet adapter with Intel chip must be used. Other network adapters may not support EtherCAT.

## 1) Install TwinCAT.

Windows XP system: tcats is recommended\_2110\_2230. Windows  
7 32-bit system: tcats is recommended\_2110\_2248.

## 2) Copy the EtherCAT configuration file (KD600\_EC.xml) of KD600 to the TwinCAT installation directory.

TwinCAT2 directory: TwinCAT IO EtherCAT

TwinCAT3 directory: TwinCAT 3.1 config IO EtherCAT

TwinCAT3 is used as an example in the next section. The operation steps of TwinCAT2 are similar.

## 3) Start TwinCAT.

Click New Project to create a project.

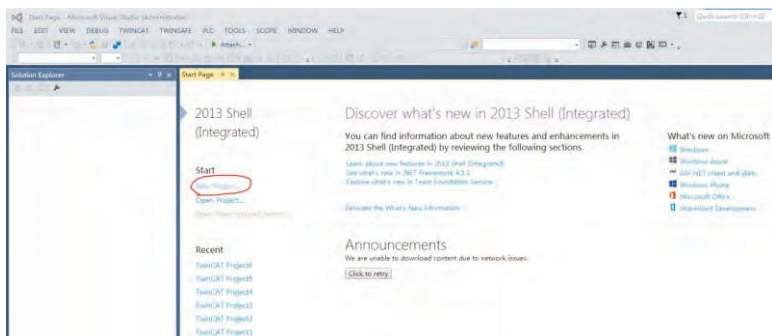

Click OK.

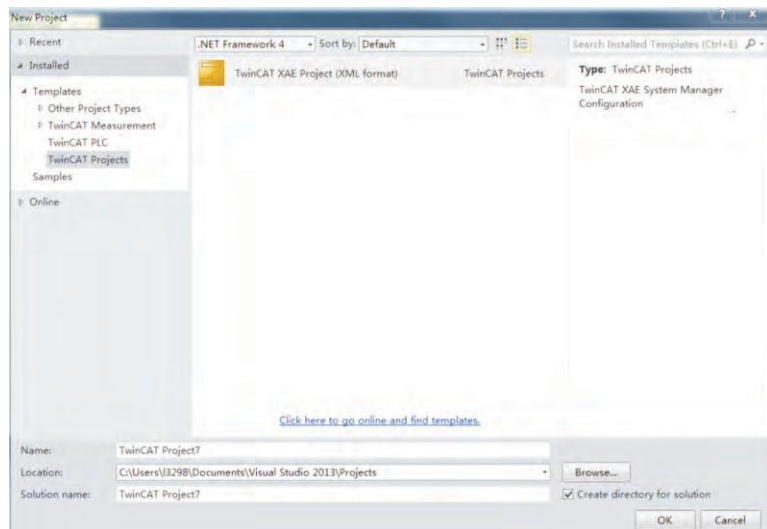

4) Install the TwinCAT network adapter driver.

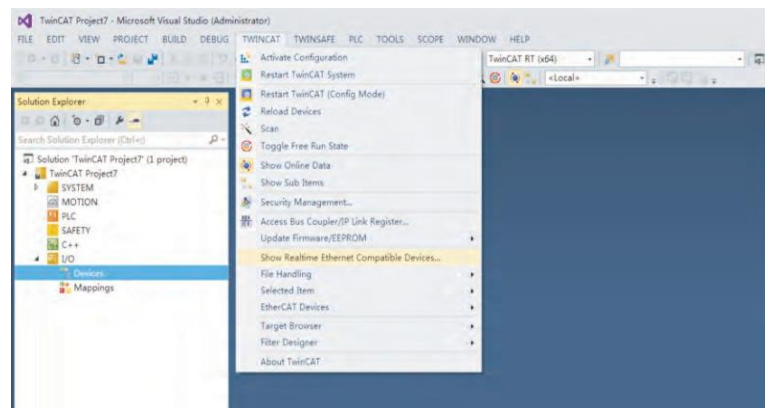

Select TWINCAT>Show Real Time Ethernet Compatible Devices. In the dialog box that appears, select the local network adapter in Incompatible Devices, and then click Install. When you install later, the installed network adapter is displayed in the Devices Installed and Ready for Use.

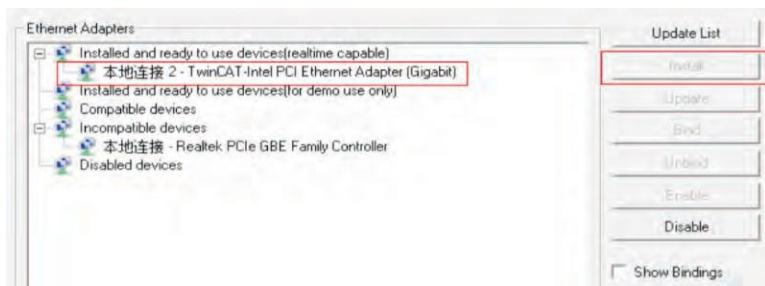

5) Search for devices. Create a project, right-click a device, and then click Scan to search for a device, as shown in the following figure.

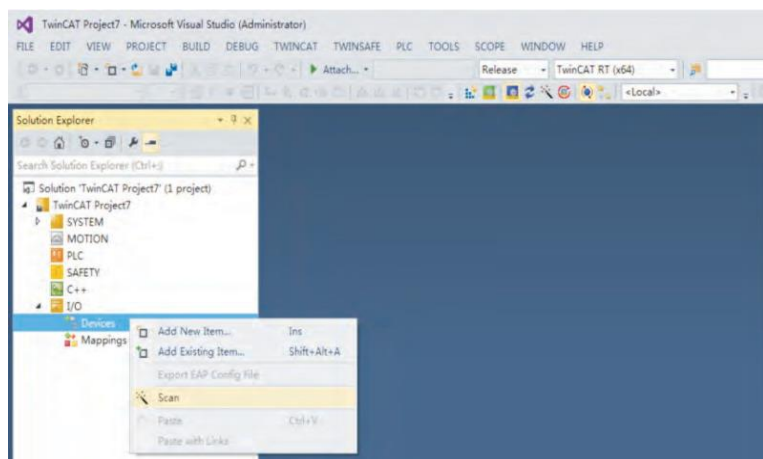

Click OK:



## Chapter 10 Appendix

---

Click OK.

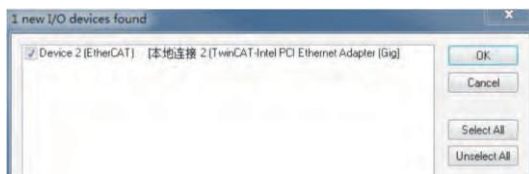

Click OK.



Click OK.

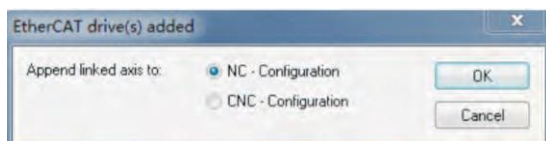

Click No, and the device search is completed, as shown in the following figure:



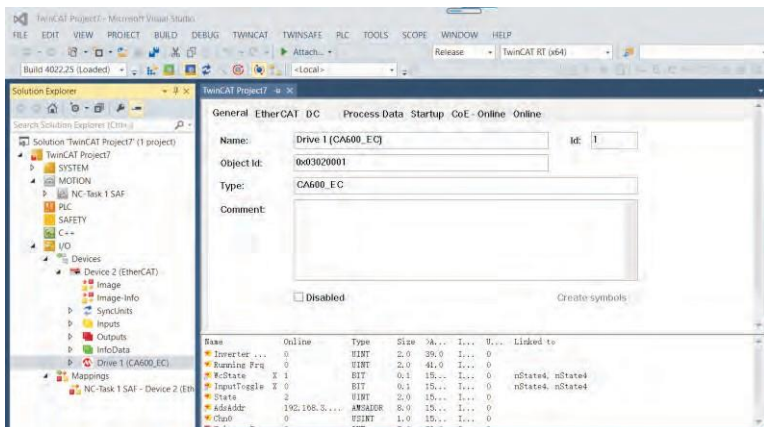

## 6) Configure PDO parameters.

## 1. Configure TPDO.

Select 0x1A00 when configuring TPDO. The first two items are set to TPDO by default and cannot be changed. Right click the position indicated by the red arrow in the following figure to add TPDO mapping as required.

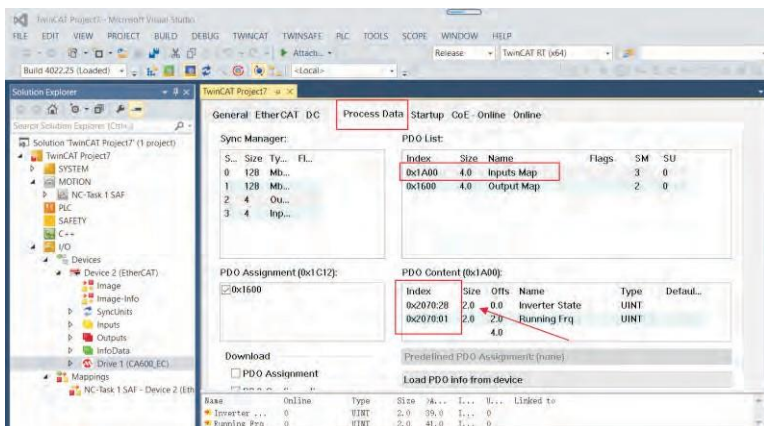

## Chapter 10 Appendix

2. Configure RPDO. Select 0x1600 when configuring RPDO. The first two items are set to RPDO by default and cannot be changed. Right click the position indicated by the red arrow in the following figure to add RPDO mapping as required.

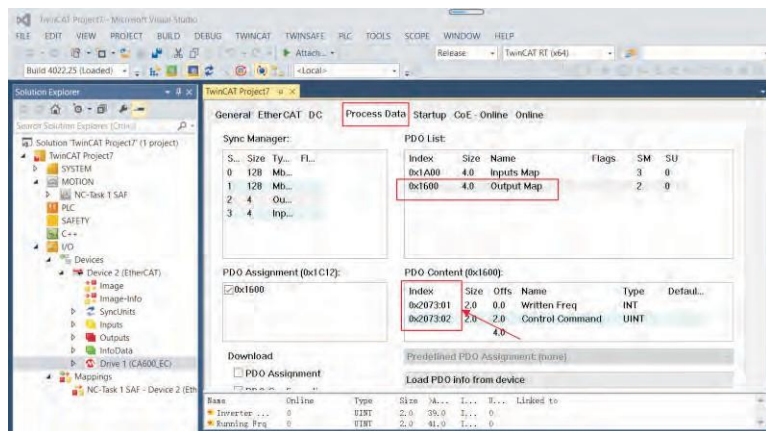

3. View SDO data list. After the OP status is activated, you can view the real-time data in the SDO data list, or double-click the object dictionary to modify the SDO data.

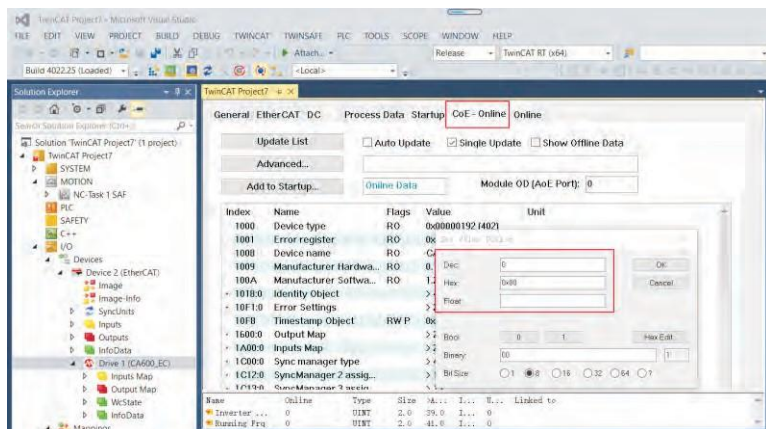

4. Activate the configuration and switch to the operating mode. Click to display the following dialog box.

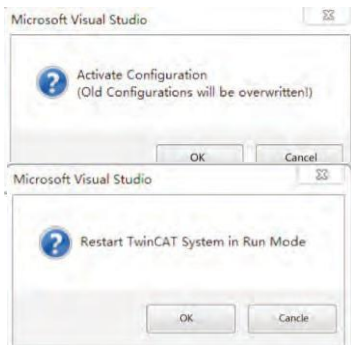

Click OK.

Click OK to enter OP status.

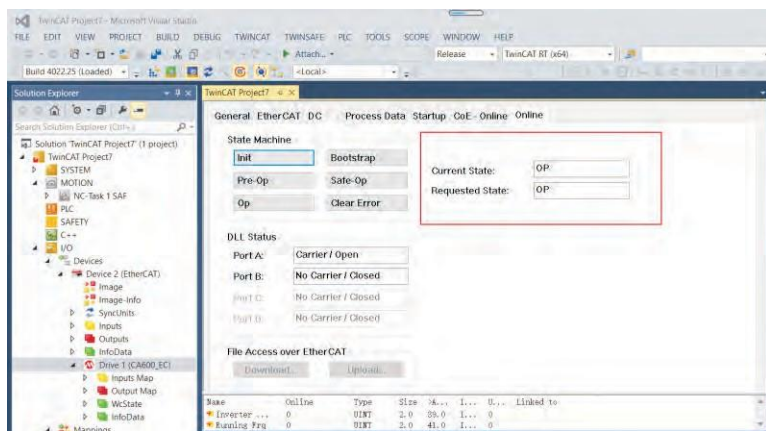

5. Control AC drive through PDO. Write the corresponding value through the configured RPDO to control the AC drive.

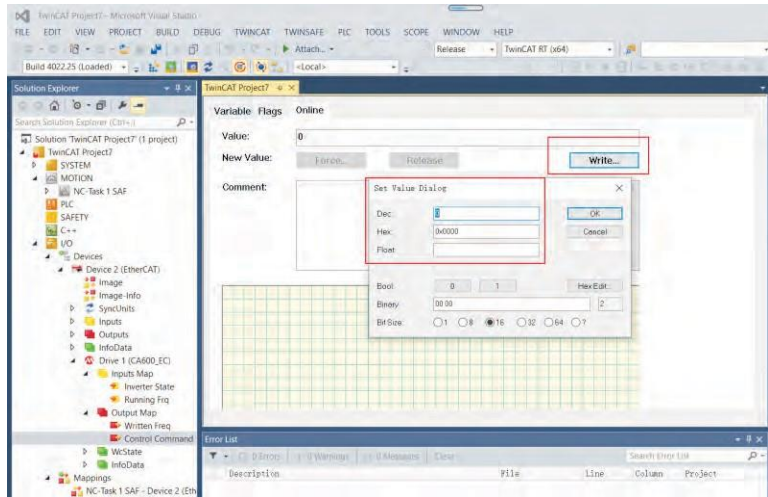

1. Troubleshooting

The following table describes the faults and AC drives that may occur during the use of the KD600-EA card.

Failure causes and solutions

Fault name	Possible causes	Solution
Communication failure between KD600-EA card and AC drive	1. The AC driver does not support EtherCAT communication. The communication configuration of the 2KD600-EA card is incorrect. 3. KD600-EA card hardware failure	1. Check whether the AC driver supports EtherCAT communication. 2. Set EtherCAT communication parameters correctly. 3. Replace the KD600-EA card

When the slave node fails, you can directly replace the KD600-EA card (only the KD600-EA card fails) without performing device configuration again.

Prerequisites for direct replacement of the KD600-EA card:

1. Before and after replacing the KD600-EA card, ensure that the wiring sequence is consistent.
2. The internal XML file versions of the original KD600-EA card and the new KD600- EA card must be consistent.
3. If the workstation alias device is configured for the original KD600-EA card, it must be consistent with the original device.

## Appendix D: KD600E elevator/lift series Vfd detailed explanations

KD600E series elevator inverter is specially developed for elevator industry. It can be used with different elevator controllers to realize open loop elevator and closed loop elevator control.

### 1.1 Single multi-speed terminal elevator controller

For the elevator controller with only one multi-segment speed changing terminal, the high-speed segment and the layer speed segment are controlled by the on- off of the high-speed terminal. The wiring diagram of such elevator controller and frequency converter is as follows:

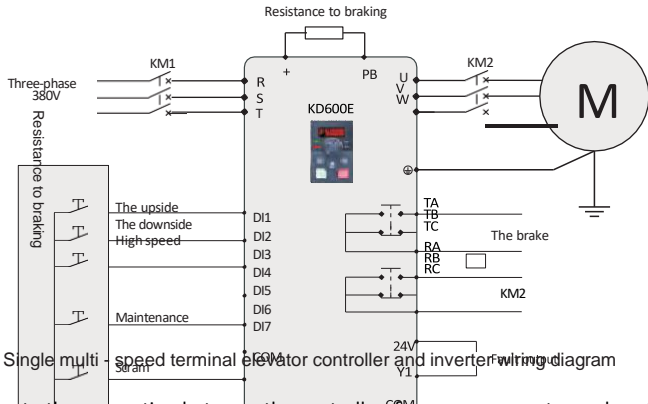

According to the connection between the controller, frequency converter and motor on site, for the elevator without running contactor (KM2), the connection of R2 can not be connected, similarly, for the elevator controller without fault signal reception, the connection of Y1 can not be connected. Complete the debugging by following the steps below:

- ⑤ the high speed and flat speed, the elevator controller uses a high-speed terminal to switch between high speed and flat speed, the corresponding set of multi-section speed parameters are: PC-00=flat speed, PC-01=high speed;
- Maintenance speed setting, some elevator controller maintenance speed and flat speed shared, no maintenance signal output, here can not be connected to the maintenance signal line, skip this step; If the maintenance signal is output, the maintenance speed can be set through the function code. The corresponding parameters for setting the maintenance speed are:C1-14=repair speed;
- Emergency stop signal, some elevator controllers do not have emergency stop signal, the emergency stop signal line can not be connected, skip this step; If there is an emergency stop signal, set DI7 as an emergency stop signal P5-06=54;
- ⑤ maintenance and operation test, switch the elevator controller to the maintenance and operation mode, and test upward or downward to check whether the running direction is consistent. If not, switch the uplink signal and the downstream signal line, that is, switch the DI1 and DI2 signal lines, or switch any two of the motor output line UVW to each other.
- Mode test run, switch the elevator controller to the normal operation mode for test, adjust the acceleration and deceleration time according to the site.

## 1.2 Double multi-speed terminal elevator controller

For the elevator controller with two multi-speed changing terminals, its high speed is controlled by the on-off of one terminal, and the other terminal is to control the flat speed or zero speed according to different controllers. The wiring diagram of the elevator controller and frequency converter with two multi-speed terminals is as follows:

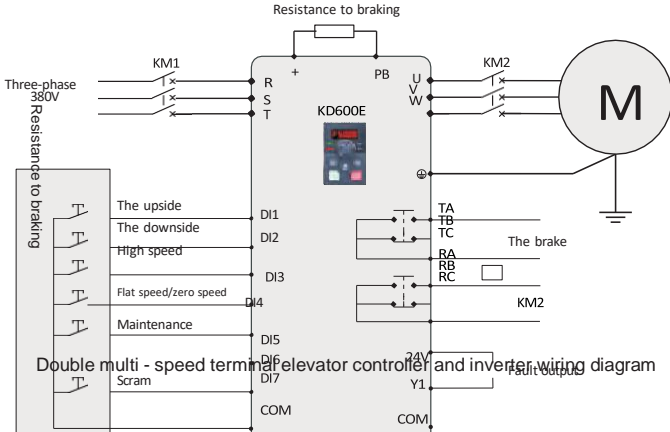

According to the connection between the controller, frequency converter and motor on site, for the elevator without running contactor (KM2), the connection of R2 can not be connected, similarly, for the elevator controller without fault signal reception, the connection of Y1 can not be connected. Complete the debugging by following the steps below:

- High speed and flat speed. The elevator controller uses two terminals to switch between high speed and flat speed. For the controller whose two terminal signals are respectively high speed and flat speed signal, the corresponding parameters for setting multi-section speed are: PC-00=0, PC-00=flat speed, PC-01=high speed;
- Maintenance speed setting, some elevator controller maintenance speed and flat speed shared, no maintenance signal output, here can not be connected to the maintenance signal line, skip this step; If there is maintenance signal output, the maintenance speed can be set by function code. The corresponding parameters for setting maintenance speed are: C1-14=maintenance speed;

- ✎ If emergency stop signal, some elevator controllers do not have emergency stop signal, the emergency stop signal line can not be connected, skip this step; if there is an emergency stop signal, set DI7 as an emergency stop signal P5- 06=54;
- ✎ maintenance and operation test, switch the elevator controller to the maintenance and operation mode and test upward or downward to check whether the running direction is consistent. If not, switch the upstream signal and the downstream signal line, that is, switch the DI1 and DI2 signal lines, or switch any two of the motor output line UVW relative;
- ✎ In mode test run, switch the elevator controller to the normal operation mode for test, adjust the acceleration and deceleration time according to the site.

### 1.3 Emergency operation mode

When the elevator is in use, if the system's power supply suddenly fails, it may result in passengers being locked in the car.

KD600E series elevator inverter can support the emergency UPS power supply operation for emergency power outage operation, and the emergency signal can be received by the inverter terminal DI6. The wiring diagram is as follows:

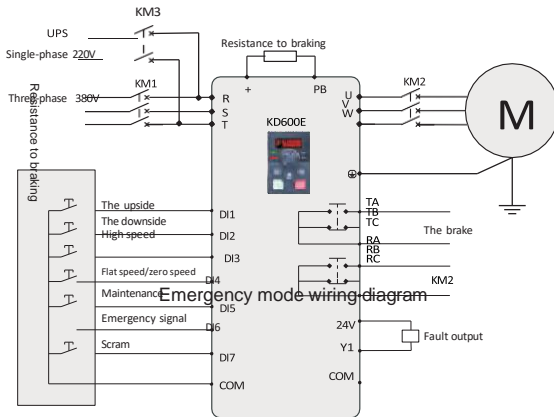

When the power grid voltage is cut off, the elevator controller switches to the UPS and sends an emergency signal to the frequency converter. When the frequency converter receives the emergency signal, the frequency converter automatically switches to the emergency mode. The KD600E supports single-phase 220V and three-phase 380V UPS power supplies.

In the emergency mode, when the elevator controller gives the frequency converter an operation signal, the frequency converter will run according to the emergency operation frequency set by C0-13, and its acceleration and deceleration time will increase and decelerate according to the time set by P7-07 and P7-08.

### 1.4 Closed loop elevator control

KD600E series elevator inverter can support closed-loop control, and provides a variety of PG cards for use with different encoders. Please refer to Chapter 5 of KD600 series User manual for PG card information. The wiring diagram of elevator controller and frequency converter for closed-loop elevator control is shown in the following figure:

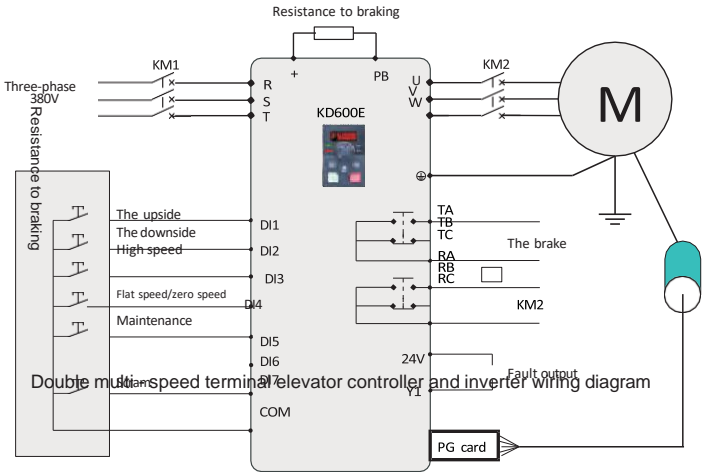

Connect the connection between controller, frequency converter and motor, and connect the connection between PG card and encoder according to the site. For the elevator without running contactor (Km2), the connection of R2 can not be connected. Similarly, for the elevator controller without fault signal reception, the connection of Y1 can not be connected. Complete the debugging by following the steps below:

- ✎ high speed and flat speed. Set the parameters of multi-section speed according to the wiring mode in the figure: PC-00=0, PC-01= flat speed, PC-02= high speed;
- Maintenance speed setting, some elevator controller maintenance speed and flat speed shared, no maintenance signal output, here can not be connected to the maintenance signal line, skip this step; If there is maintenance signal output, the maintenance speed can be set by function code. The corresponding parameters for setting maintenance speed are: C1-14 maintenance speed;
- Emergency stop signal, some elevator controllers do not have emergency stop signal, the emergency stop signal line can not be connected, skip this step; If there is an emergency stop signal, set DI7 as an emergency stop signal P5-06=54;
- ✎ maintenance and operation test, switch the elevator controller to the maintenance and operation mode and test upward or downward to check whether the running direction is consistent. If not, switch the upstream signal and the downstream signal line, that is, switch the DI1 and DI2 signal lines, or switch any two of the motor output line UVW relative;
- ✎ the direction of the encoder, switch the elevator controller to the maintenance operation mode, according to the uplink or downlink test, check the output frequency should be consistent with the positive or negative of the feedback speed of the U1-46 encoder, that is, if the output frequency is positive, the feedback speed of U1-46 also needs to be positive; If the output frequency is negative, the feedback speed of U1-4 should also be negative. If the direction is inconsistent, P4-29 can be set to 1 or the A and B phase pulses of the encoder can be switched. After completion, check again whether the output frequency is consistent with the direction of U1-46 ;

- ✎ In closed-loop control mode, set the number of code lines P4-28 according to the encoder, set P0-03 to 3, turn it into closed-loop control mode, switch the elevator controller to the maintenance operation mode, and test upward or downward to check whether the elevator runs normally;
- ✎ In mode test run, switch the elevator controller to the normal mode for test, adjust the acceleration and deceleration time according to the site.

## 1.5 Multi-segment speed setting method

For different elevator controllers, the different combinations of signals output by the control multi-segment speed terminals will lead to different parameter positions for setting flat speed and high speed. The corresponding speed setting parameters of the combination are shown in the following table:

DI4(P5-03=13)	DI3(P5-04=12)	Speed setting parameters
0	0	PC-00
0	1	PC-01
1	0	PC-02
1	1	PC-03

The speed parameter of the PC group is set as a percentage. 100.0% corresponds to the maximum frequency (the value set by P0-14). Meanwhile, the corresponding acceleration and deceleration time can be set separately for each speed segment. The corresponding acceleration and deceleration time selection for each speed segment is shown in the following table:

Multiple segment velocity	Acceleration and deceleration time selection parameter
PC-00	PC-19
PC-01	PC-21
PC-02	PC-23
PC-03	PC-25

The KD600E supports four sets of acceleration and deceleration times. The parameters for selecting the time range from 0 to 3. The parameters for setting the corresponding acceleration and deceleration times are shown in the following table:

Project	Group 0	Group 1	Group 2	Group 3
Time of acceleration	P0-23	P7-03	P7-05	P7-07
Time of deceleration	P0-24	P7-03	P7-06	P7-08

## 1.6 C1 Group function code Description

For different elevator controllers, the different combinations of signals output by the control multi-segment speed terminals will lead to different parameter positions for setting flat speed and high speed. The corresponding speed setting parameters of the combination are shown in the following table:

Function code	Name	Description (setting range)	Factory Default	Change
C1-01	Private machine control	0: invalid	1	x
		1: Effective		

0: invalid

No lock logic 1;

1: Effective

It is a special elevator model, and C1 group parameters are valid.

Function code	Name	Description (setting range)	Factory Default	Change
C1-01	Hold brake opening delay	0.0s~10.00s	0.00s	x
P1-04	Start up frequency	0.00Hz~10.00Hz	5.00Hz	x
P1-05	Start frequency hold time	0.0s~10.00s	0.00s	x
C1-02	Holding brake closing frequency delay	0.0s~10.00s	0.30s	x
C1-03	Opening frequency of lock brake (rising)	0.00Hz~10.00Hz	1.00Hz	x
C1-04	Lock closing frequency (rising)	0.00Hz~10.00Hz	0.20Hz	x
C1-05	Opening frequency of lock brake (decreasing)	0.00Hz~10.00Hz	1.00Hz	x

Function code	Name	Description (setting range)	Factory Default	Change
C1-06	Lock closing frequency (decreasing)	0.00Hz~10.00Hz	0.20Hz	x
C1-07	Hold the brake to turn on the current	0.0~100.0%	40.0%	Δ
C1-08	Holding time of opening frequency of lock brake	0.00~10.00s	0.30s	x
C1-09	Closing frequency holding time of lock brake	0.0s~10.00s	0.20s	x
C1-10	Running contactor closing delay	0.0s~10.00s	0.10s	x
C1-11	Run contactor open delay	0.0s~10.00s	0.50s	x

By setting the function codes C1-00~C1-19, the starting comfort and stopping comfort of the elevator can be well adjusted. The exact meaning of each function code is as follows:

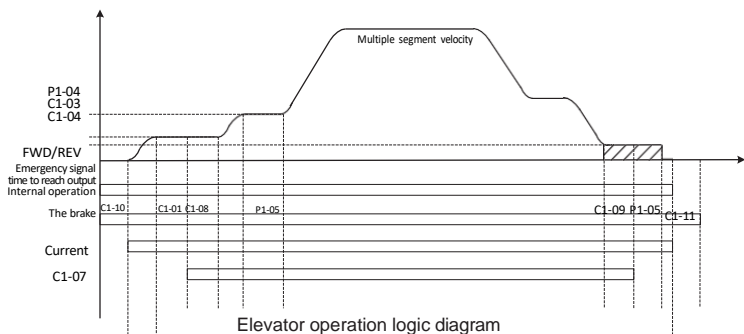

C1-03(lock gate opening frequency (up)) and C1-04(lock gate closing frequency (up)) have the same meaning as C1-05(lock gate opening frequency (down)) and C1-06(lock gate closing frequency (down)). The rising group is used for frequency judgment when the converter is in positive rotation, while the falling group is used for frequency judgment when the converter is in reverse rotation.

Function code	Name	Description (setting range)	Factory Default	Change
C1-12	Hold brake open type	0: Turns on according to the frequency	0	x
		1: Turn on according to frequency and current		

0: Turns on according to the frequency

The opening judgment condition of the lock brake is that the inverter outputs to the frequency set by C1-03(up) C1-05 (down), and then opens the lock brake after the time set by C1-01(lock brake opening delay).

1: Turn on according to frequency and current

In addition to the frequency set by C1-03 (up) and C1-05 (down), the current of the converter should also reach the value set by C1-07(open current of the lock gate).

Function code	Name	Description (setting range)	Factory Default	Change
C1-13	Emergency operating frequency	0.00~50.00Hz	20.00Hz	Δ

When the emergency signal is input, the inverter will enter the emergency running state, and the running frequency is the frequency set by the function code. In the emergency running state, the inverter will select acceleration and deceleration time 4 as the current acceleration and deceleration time.

Function code	Name	Description (setting range)	Factory Default	Change
C1-14	Maintenance operating frequency	0.00~50.00Hz	20.00Hz	Δ

When the maintenance signal is input, the operation frequency of the inverter will be operated according to the maintenance operation frequency.

Function code	Name	Description (setting range)	Factory Default	Change
C1-15	Emergency signal processing	0: The elevator is not running	1	x
		1: The UPS runs		

0: The elevator is not running

When there is an emergency signal input, the inverter will not output. 1: The UPS runs

When there is an emergency signal input, the inverter is powered by the UPS, and the inverter can run and output at the emergency frequency.

Function code	Name	Description (setting range)	Factory Default	Change
C1-16	Ascending correction frequency	0.00~3.00Hz	0.00Hz	x

This parameter is used to correct the flat accuracy of the elevator in the power generation mode. For example, when the elevator is just in the flat position when it is rising with half load, and exceeds the flat position when it is rising with no load, increasing this value can correct the flat accuracy.

Function code	Name	Description (setting range)	Factory Default	Change
C1-17	Drop correction frequency	0.00~3.00Hz	0.00Hz	x

This parameter is used to correct the flat accuracy of the elevator in electric mode. For example, when the elevator is just in the flat position when the half load drops, but cannot reach the flat position when the no load drops, increasing this value can correct the flat accuracy.

Function code	Name	Description (setting range)	Factory Default	Change
C1-18	Emergency signal validity time	0.0~500.0s	10.0s	x
C1-19	Emergency signal invalid time	0.0~1000.0s	180.0s	x

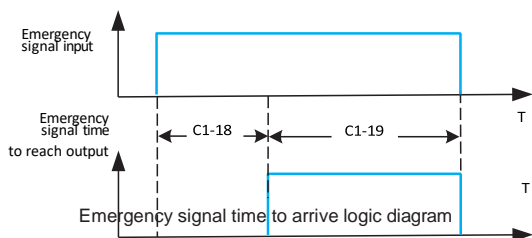



# WARRANTY

- 1** The company solemnly promises that users will enjoy the following warranty **is** from the date of purchase of products from our company (hereinafter referred to as the manufacturer).
- 2** The product was purchased by the user from the manufacturer, enjoy the following three guarantee services:

  - Replacement** and repair within 30 days of delivery:
  - Replacement** and repair within 90 days of delivery:
  - Repair** within 18 months of delivery:
  - Except** when exporting abroad.
- 3** This product enjoys lifetime paid service from the date of purchase by the user **for** the manufacturer.
- 4** The Product failure caused by the following reasons is not covered by the manufacturer's free warranty service:

  - Caused** by the user's use and operation in accordance with the requirements of the «Instruction Manual»:
  - Caused** by the user to repair or modify the product without communicating with the manufacturer:
  - Caused** by abnormal aging of the product due to poor user environment:
  - Caused** by natural disasters such as earthquakes, fires, floods or abnormal voltages:
  - Due** to the product during transportation (the transportation method is specified by the customer, and the company assists in handling the cargo consignment procedures)
- 5** The following conditions, manufacturers have the right not to provide warranty services:

  - When** the manufacturer's product logo, trademark, nameplate, etc. are damaged **or** unrecognizable:
  - When** the user fails to pay the purchase price in accordance with the signed contract:
  - When** user intentionally conceals the manufacturer's after-sales service unit when the product is installed, wired, operated, maintained or otherwise improperly used
- 6** **For** the service of return, replacement and repair, the company must return **it** to the company, and it can only be returned or repaired after confirming the responsibility vested.

## WARRANTY CARD

User information			
User name			
User address			
Postal code		Contact person	
Tel		Fax	
Machine type		Machine code	
Agent / Reseller Information			
Supplier			
Contact			
Tel		Delivery date	

## CERTIFICATE OF QUALITY

**QC test :** \_\_\_\_\_

This product has been tested by our company's quality department, and its performance meets the standards, passes the inspection, and is approved to leave the factory.

